

TECHNISCHE ÄNDERUNGEN VORBEHALTEN · NACHDRUCK UND KOPIEN NUR MIT UNSEREM EINVERSTÄNDNIS · Specifications subject to change without notice · Copyright ELAFLEX

GRUPPE 5 Section	AUSFÜHRUNG · WERKSTOFFE · GEWICHT VERWENDUNGSBEREICH <i>Construction Details Materials · Weight</i> <i>Specification</i>	SCHLAUCH- ANSCHLUSS <i>Hose Inlet Thread Type + Size</i> G	BESTELL- NUMMER <i>Part Number</i> Type
-------------------------------	---	---	--

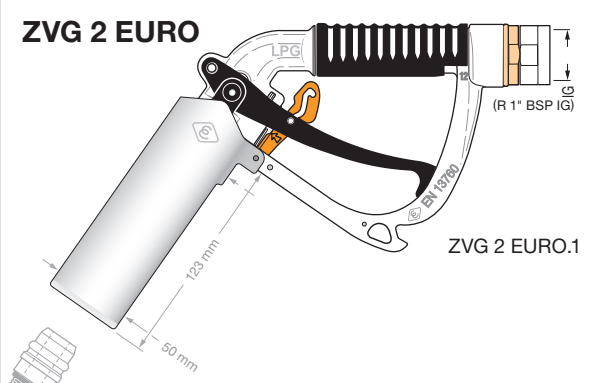

<p>Flüssiggas-Zapfventil zur LPG-Fahrzeugbetankung mit Propan, Butan und deren Gemischen bis 50 l/min. Betriebsdruck 25 bar. Prüfdruck 40 bar. Berstdruck > 100 bar. Temperaturbereich -25° bis +70° Celsius, 'LT'-Type bis -40° Celsius.</p> <p>Sicherheitsmerkmale: Lässt sich nur öffnen, wenn mechanisch sicher mit Füllanschluss verbunden wurde. Keine Öffnung bei verkanteter Aufkupplung möglich. Beim Abkuppeln selbsttätige Entspannung, minimierte Gasmenge – die Austrittsrichtung ist vom Bediener abgewandt.</p> <p>Modularer Aufbau: Der Ventilkörper ist für alle Kupplungstypen gleich. Gehäuse Alu, Kälteschutz PVC, Leichtgangdrehgelenk EA 820 Edelstahl/Messing, Kupplungshülse Edelstahl (DISH: Aluminium), Innenteile Edelstahl/Delrin/PA, Schalthebel und Aufhalteraste PA. Dichtungen NBR und PU.</p> <p>ACME 1 3/4" (Schraubkupplung) für Kfz-Stutzen nach DIN EN 12806. Entspannungsvolumen: ca. 1,7 cm³. Gewicht: ≈ 1,5 kg</p> <p>DISH ('Italienische' Klauenkupplung) für Kfz-Stutzen nach DIN EN 12806. Einhandbedienung möglich. Entspannungsvolumen: < 1 cm³. Gewicht: ≈ 1,2 kg</p> <p>EURO (Steckanschluss) Kupplung nach DIN EN 13760. Einhandbedienung möglich. Entspannungsvolumen: < 1 cm³. Gewicht: ≈ 1,4 kg</p> <div style="border: 1px solid black; padding: 5px; margin-top: 10px;"> <p>TÜV-Zertifikat Nr. 1321 Z 0040/8/01, geprüft nach Anforderungen der DIN EN 13760 durch TÜV NORD. Erfüllt Anforderungen des VdTÜV-Merkblattes 513 ATEX (© II 1 G) Zertifikat Nr. SIRA 09 ATEX 9204U.</p> </div> <p style="text-align: center;">—</p> <p>LPG nozzle for vehicle refuelling with liquefied petroleum gas (propane, butane and mixtures) up to 50 l/min. Working pressure 25 bar. Test pressure 40 bar. Burst pressure > 100 bar. Temperature range -25° up to +70° C, 'LT'-Type down to -40° C.</p> <p>Safety features: The nozzle only allows gas to flow when it is correctly coupled. No opening possible when coupled misaligned or tilted. The discharge volume of gas when uncoupling is minimal, direction of discharge turned away from the user.</p> <p>Modular construction: Nozzle body (e.g. valve body and operating mechanism) identical for all coupling types. Nozzle body aluminium, comfigrip PVC, easy rotating swivel EA 820 stainless steel/brass, coupling nut stainless steel (DISH: aluminium), inner parts stainless steel/acetel resin/PA, lever and latch PA. Seals NBR and PU.</p> <p>ACME 1 3/4" (Threaded Coupling) for vehicle connections to EN 12806. Gas release volume: approx. 1,7 cm³. Weight: ≈ 1,5 kg</p> <p>DISH ('Italian' Claw Coupling) for vehicle connections to EN 12806. One-handed operation possible. Gas release volume: < 1 cm³. Weight: ≈ 1,2 kg</p> <p>EURO (Push-In-Coupling) Coupling to EN 13760. One-handed operation possible. Gas release volume: < 1 cm³. Weight: ≈ 1,4 kg</p> <div style="border: 1px solid black; padding: 5px; margin-top: 10px;"> <p>TÜV-approved according to EN 13760, certificate number 1321 Z 0040/8/01. Fulfills the requirements of VdTÜV sheet 513. ATEX (© II 1 G) certificate no. SIRA 09 ATEX 9204U.</p> </div>	<table border="1"> <tr> <td>R 1" IG 1" BSP female</td> <td>ZVG2 ACME.1</td> </tr> <tr> <td>3/4" NPT IG 3/4" NPT female</td> <td>ZVG2 ACME.3</td> </tr> <tr> <td>M 30 x 1,5 L AG (L = Linksgewinde) M 30 x 1,5 L male (L = left-hand thread)</td> <td>ZVG2 ACME.5</td> </tr> <tr> <td>R 1" IG 1" BSP female</td> <td>ZVG2 DISH.1</td> </tr> <tr> <td>3/4" NPT IG 3/4" NPT female</td> <td>ZVG2 DISH.3</td> </tr> <tr> <td>M 30 x 1,5 L AG (L = Linksgewinde) M 30 x 1,5 L male (L = left-hand thread)</td> <td>ZVG2 DISH.5</td> </tr> <tr> <td>R 1" IG 1" BSP female</td> <td>ZVG2 EURO.1</td> </tr> <tr> <td>3/4" NPT IG 3/4" NPT female</td> <td>ZVG2 EURO.3</td> </tr> <tr> <td>M 30 x 1,5 L AG (L = Linksgewinde) M 30 x 1,5 L male (L = left-hand thread)</td> <td>ZVG2 EURO.5</td> </tr> </table>	R 1" IG 1" BSP female	ZVG2 ACME.1	3/4" NPT IG 3/4" NPT female	ZVG2 ACME.3	M 30 x 1,5 L AG (L = Linksgewinde) M 30 x 1,5 L male (L = left-hand thread)	ZVG2 ACME.5	R 1" IG 1" BSP female	ZVG2 DISH.1	3/4" NPT IG 3/4" NPT female	ZVG2 DISH.3	M 30 x 1,5 L AG (L = Linksgewinde) M 30 x 1,5 L male (L = left-hand thread)	ZVG2 DISH.5	R 1" IG 1" BSP female	ZVG2 EURO.1	3/4" NPT IG 3/4" NPT female	ZVG2 EURO.3	M 30 x 1,5 L AG (L = Linksgewinde) M 30 x 1,5 L male (L = left-hand thread)	ZVG2 EURO.5
R 1" IG 1" BSP female	ZVG2 ACME.1																		
3/4" NPT IG 3/4" NPT female	ZVG2 ACME.3																		
M 30 x 1,5 L AG (L = Linksgewinde) M 30 x 1,5 L male (L = left-hand thread)	ZVG2 ACME.5																		
R 1" IG 1" BSP female	ZVG2 DISH.1																		
3/4" NPT IG 3/4" NPT female	ZVG2 DISH.3																		
M 30 x 1,5 L AG (L = Linksgewinde) M 30 x 1,5 L male (L = left-hand thread)	ZVG2 DISH.5																		
R 1" IG 1" BSP female	ZVG2 EURO.1																		
3/4" NPT IG 3/4" NPT female	ZVG2 EURO.3																		
M 30 x 1,5 L AG (L = Linksgewinde) M 30 x 1,5 L male (L = left-hand thread)	ZVG2 EURO.5																		
Zusatz-Bestell-Nummern · Additional Type Numbers																			
Mit Blockmagnet im Bügel/With block magnet integrated in the guard	... M																		
Ohne Aufhalteraste/Without hold-open latch	... D																		
Spezialtype für kalte Gebiete bis -40°C/Low Temperature type up to -40°C	... LT																		

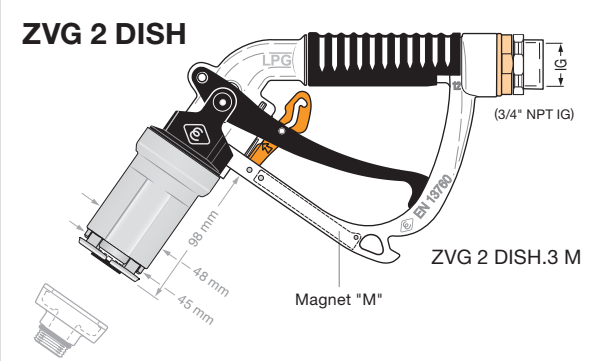
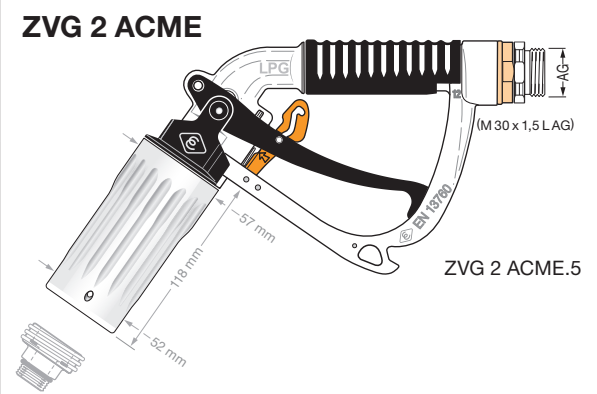

Für Bajonett-Kupplungen empfehlen wir die Type GasGuard GG 30, siehe Katalogseiten 567.
For Bayonet couplings we recommend the type GasGuard GG30, see catalogue page 567.

2009 Revision 4.2013	<p>Bestellnummern-Erläuterung ZVG 2 siehe Information 3.09 or http://zapfventilconfigurator.elaflex.de</p> <p>Order number breakdown, see Information 3.09 or http://nozzleconfigurator.elaflex.de</p>
-------------------------	--

Flüssiggas-Zapfventil ZVG 2
LPG NOZZLE ZVG 2
561

Ersatzteile ZVG 2 · Spare Parts ZVG 2

- 1) Zapfventil-Gehäuse wird nicht als Ersatzteil geliefert.
- 1) Nozzle body is not available as spare part.

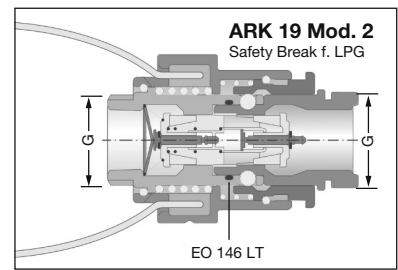
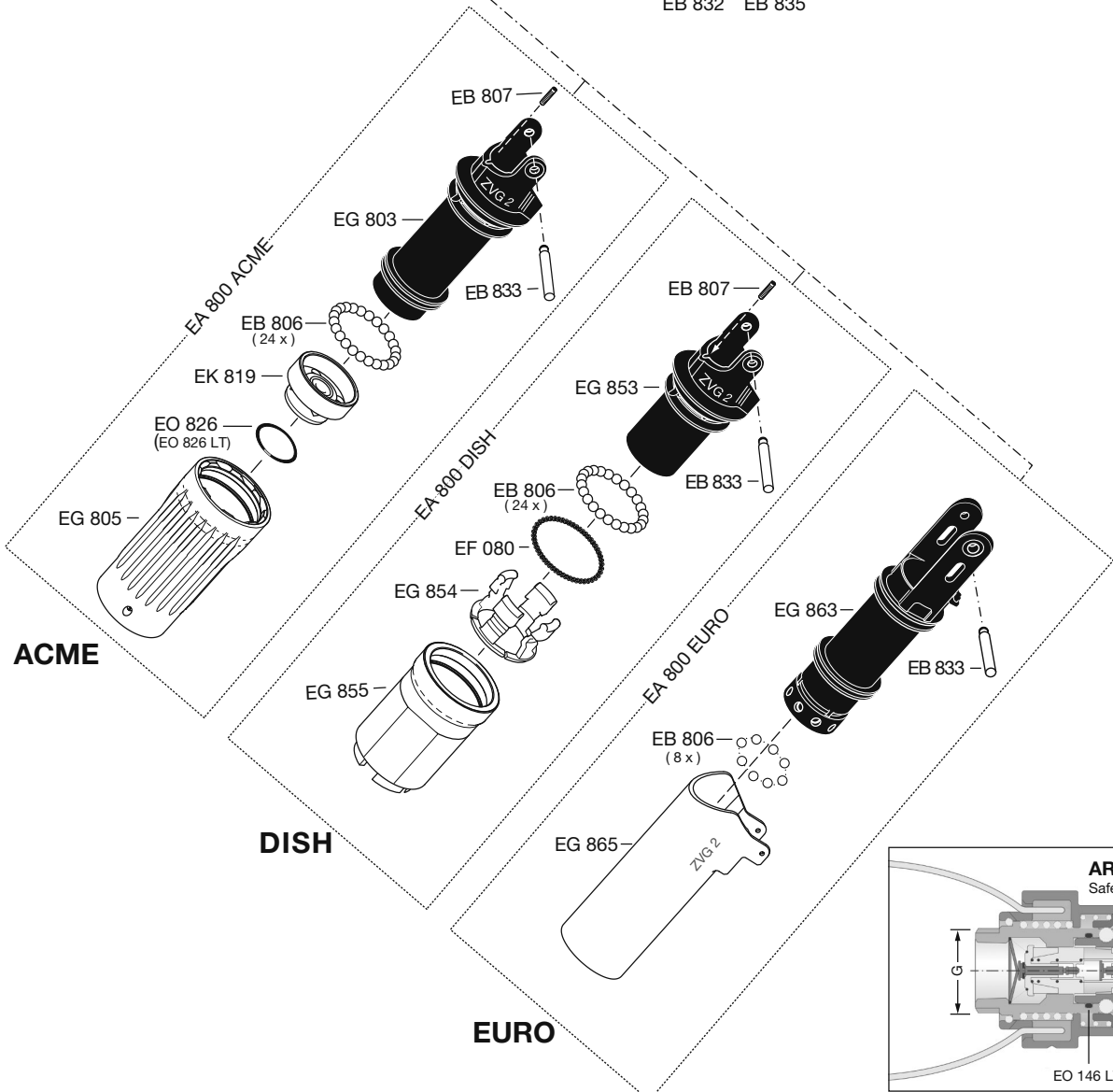
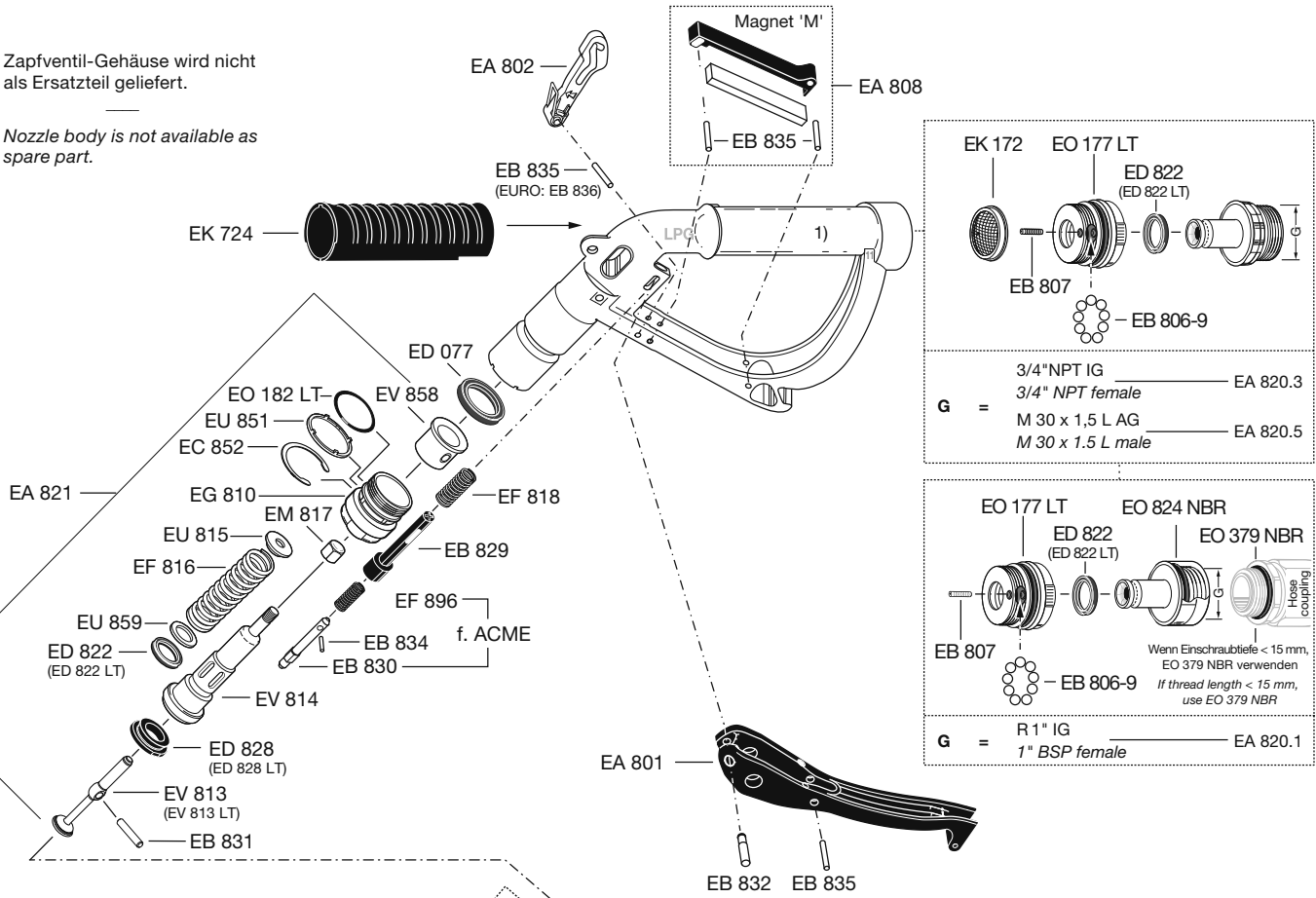

TECHNISCHE ÄNDERUNGEN VORBEHALTEN · NACHDRUCK UND KOPIEN NUR MIT UNSEREM EINVERSTÄNDNIS · SPECIFICATIONS SUBJECT TO CHANGE WITHOUT NOTICE · COPYRIGHT ELAFLEX

GRUPPE 5 Section	AUSFÜHRUNG · WERKSTOFFE · GEWICHT VERWENDUNGSBEREICH <i>Construction Details Materials · Weight</i> Specification	SCHLAUCH- ANSCHLUSS <i>Hose Inlet Thread Type + Size</i> G	BESTELL- NUMMER <i>Part Number</i> Type
-------------------------------	--	---	--



<p>STANDARD-AUSFÜHRUNG: Sicherheits-Abreißkupplung für LPG Autogas Zapfschläuche mit selbstschließenden Rückschlagventilen entsprechend TRG 404 und EN 14678-1 auf beiden Seiten. Korrosionsfestes Gehäuse aus Rotguss mit drucktragenden Teilen aus Messing. Kugeln aus Edelstahl. Ventilteller aus Delrin. Dichtungen aus NBR. Mit Break Sleeve BS 19 aus Polyurethan. Mit Edelstahl-Seil für Rammpfahl- oder Zapfsäulenbefestigung, Länge ≈ 300 mm (andere Längen auf Anfrage). Gewicht ≈ 1.05 kg.</p> <div style="border: 1px solid black; padding: 5px; text-align: center;">TÜV-Zulassung Nr. TÜV.ST. BCD.007-06.</div> <p style="text-align: center;">—</p> <p>STANDARD SPECIFICATION: <i>Safety Break coupling for LPG autogas hoses with self-closing check valves on both ends according to EN 14678-1 and German safety rules.</i> <i>Corrosion-resistant body of bronze with pressurized parts of brass. Balls of stainless steel. Poppet assembly of acetal resin. Seals of NBR. With break sleeve BS 19 of polyurethane.</i> <i>With stainless steel lanyard for fastening at stanchion or pump, cable length ≈ 300 mm (Other lengths on request). Weight ≈ 1,05 kg.</i></p> <div style="border: 1px solid black; padding: 5px; text-align: center;">Certificate No. TÜV.ST. BCD.007-06.</div>	<p>Der Einbau der ARK erfolgt in der Regel zwischen einem kurzen Verbindungsschlauch und dem langen LPG-Zapfschlauch (s. Abbildung). Die Abreißkupplung öffnet bei einer axialen Zugbelastung von 200 N bis 500 N gemäß EN 14678-1. Beide Hälften schließen dabei selbsttätig. Der Gasverlust ist minimal. Die ARK kann ohne Werkzeug unter Druck wieder zusammengekuppelt werden.</p> <p style="text-align: center;">—</p> <p><i>Generally the ARK is assembled between a short connection hose and the long LPG hose (see picture).</i> <i>The ARK separates at an axial pull of 200 N up to 500 N corresponding to EN 14678-1. Both parts close automatically. The escape of gas is minimal.</i> <i>ARK can be reassembled under pressure without tools.</i></p>	<p>Abreißkupplung DN 19 für Flüssiggas-Schläuche. Unter Druck von Hand wieder kuppelbar, kein Werkzeug erforderlich. Für Propan und Butan bis zu 50 l/min. Temperaturbereich -25° C bis +70° C Betriebsdruck 25 bar. Prüfdruck 40 bar. Berstdruck > 100 bar.</p> <p><i>Safety Break DN 19 for LPG hoses. Reconnectable under pressure without tools. For propane/butane up to 50 l/min. Temperature range -25°C to +70°C. Working pressure 25 bar, test pressure 40 bar, burst pressure > 100 bar.</i></p> <p>ARK 19 Mod. 2</p> <p>LPG 16 3 - 5 mtr. BS 19 Break Sleeve LPG 16 0,3 - 1,0 mtr.</p> <p>ARK 19.3</p> <p>ARK 19.5</p>
<p>Type LPG 16 ist ein hoch flexibler, langlebiger Standard-Zapfschlauch für die Autogas-Betankung mit weichmacherfreiem Innengummi aus NBR. Basierend auf dem Slimline Zapfschlauch. Schwarze, glatte Oberfläche, geprickt. Gewicht ca. 0,5 kg/m.</p> <p>Kennzeichnung: Fortlaufende Markierung in dauerhaft abriebfester Qualität:</p> <p style="border: 1px solid black; padding: 2px;">LPG 16 - EN 1762 · D · - 40° · Ω · PN 25 · M · ELAFLEX © GERMANY · 04.13</p> <p><i>Type LPG 16 is a highly flexible, long lasting standard Autogas hose for LPG dispensers with plasticiser-free lining of NBR.</i> <i>Based on the Slimline petrol pump hose, black, smooth cover, perforated. Weight approx. 0,5 kg/m.</i> Marking: Continuous, abrasion resistant as per example above.</p>	<p>LPG 16</p> <p style="text-align: right;">siehe Katalogseite 116 see catalogue page 116</p> <p><i>Hose for LPG dispensers. Meets EN 1762 and TRbF 131. For propane, butane and other L. P. gases. Burst pressure > 100 bar. Temperature range -40° C up to +70° C. DVGW approval No. DG-4621AU 0049.</i></p>	

GE- WICHT <i>Weight</i> ≈ kg	AUSFÜHRUNG · WERKSTOFFE VERWENDUNGSBEREICH <i>Construction Details Materials · Application</i> Specification	GEWINDE ART + GRÖSSE <i>Thread Type + Size</i> G	BESTELL- NUMMER <i>Part Number</i> Type
0,16	<p>Vater- bzw. Mutterschraubungen mit Schraubhülsen-Einband, geeignet zur Selbstmontage.</p> <p>Entsprechen DIN EN 14424 und Bundeswehnorm VG 95951. Nenndruck bis 25 bar.</p>	<p>3/4" NPT AG 3/4" NPT male</p>	<p>V 16-3/4" NPT</p>
0,17	<p><i>Hose couplings (ferrule type) with union nut (male/female thread), suitable for self-assembly.</i></p>	<p>1" AG 1" BSP male</p>	<p>V 16-1"</p>
0,17	<p><i>Working pressure up to 25 bar. Meet EN 14424.</i></p>	<p>M 30 x 1,5 L IG (L = Linksgewinde) M 30 x 1,5 L female (L = left-hand thread)</p>	<p>M 16-30 LPG</p>

<p>Schlauchstutzen und Hülse: Messing blank gebeizt</p> <p>Type V</p> <p><i>Hose tail and ferrule of brass.</i></p> <p style="text-align: right;">siehe Katalogseite 203 + 205 see catalogue page 203 + 205</p>	
<p>Schlauchstutzen, Hülse und Mutter aus Messing. Dichtung Polyurethan</p> <p>Type M</p> <p><i>Hose tail, union nut and ferrule of brass. Captive seal polyurethane</i></p> <p style="text-align: right;">Kontrollfenster/ control opening</p>	

<p>2009 Revision 4.2013</p>	<p>Flüssiggas-Zapfventil ZVG 2</p> <p>LPG NOZZLE ZVG 2</p>
---------------------------------	---

<p>2009 Revision 4.2013</p>	<p>Flüssiggas-Zapfventil ZVG 2</p> <p>LPG NOZZLE ZVG 2</p>
---------------------------------	---

Druckverlustkurven

für Flüssiggas-Zapfventil ZVG 2
und Abreißkupplung ARK 19

Pressure Drop Chart

for LPG nozzle ZVG 2 and
Safety Break coupling ARK 19

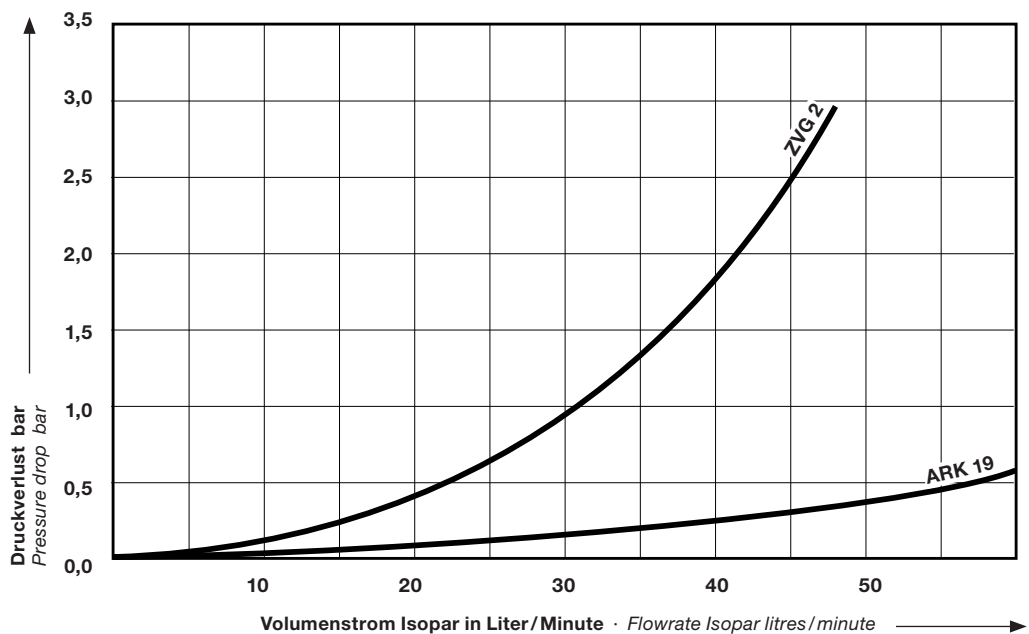

Diese Werte wurden mit ZVG 2 ACME, DISH und EURO ermittelt. Es wurden handelsübliche Anschlüsse ohne Rückschlagventil verwendet. In der Praxis gibt es eine Vielzahl unterschiedlicher Kfz-Anschlüsse/Adapter. Hierbei können Abweichungen zu den gemessenen Werten auftreten.

These values were determined with ZVG 2 ACME, DISH and EURO. Common adapters without check valve were used. There are a wide variety of connections/adapters for cars used in market. This can lead to different values.

Das komplette System für LPG-Zapfsäulen · The complete kit for LPG dispensers

