

# BASIC LINE CATALOGUE

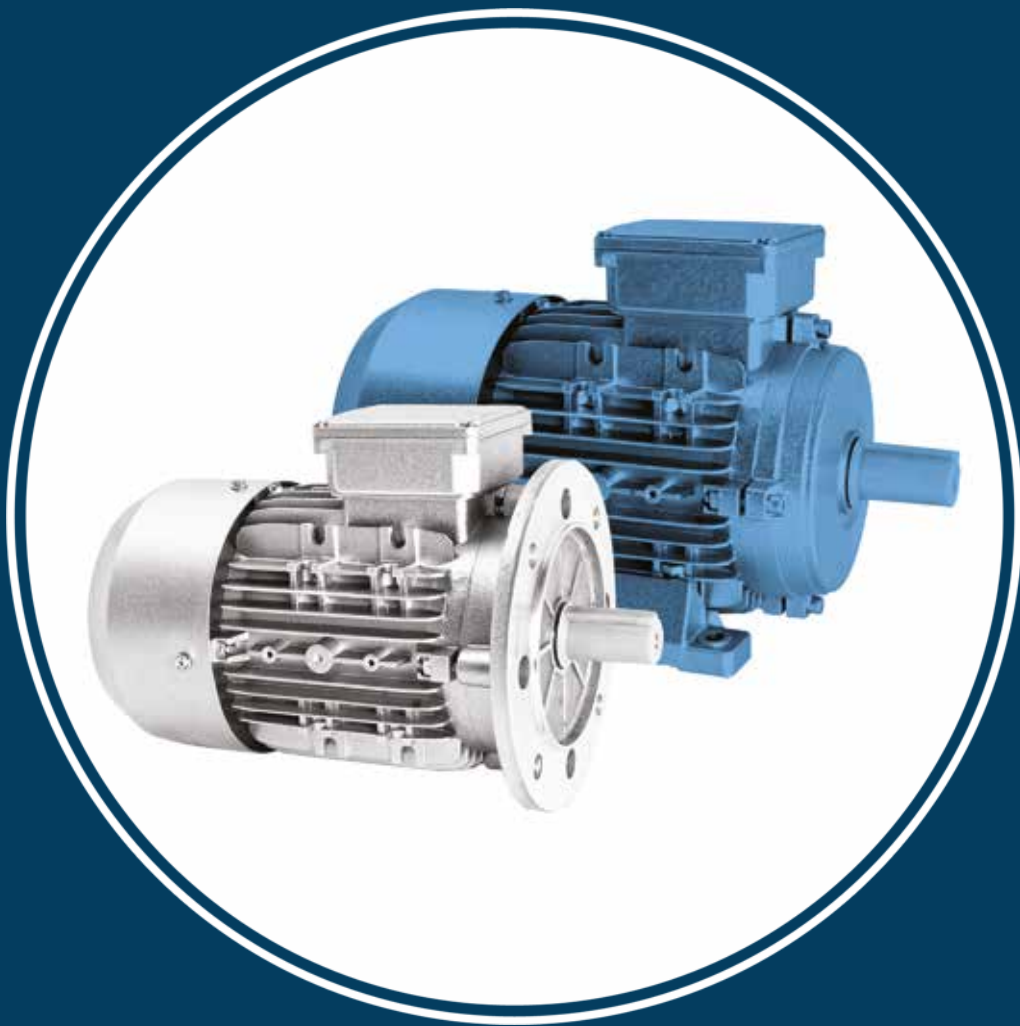

**NERIMOTORI**  
Experience the power

**NERI MOTORI s.r.l**

Via Fleming, 6/8

40017 San Giovanni in Persiceto - Bologna - ITALY

Tel. +39 051/6870911 - Fax +39 051/825858

info@nerimotori.com

www.nerimotori.com

MOD.MR.2004 - REV3 - 06/13



## Neri Motori

Neri Motori are an excellent example of an Italian company able to combine industrial development and handcrafted care in their customer services.

The company is based in San Giovanni in Persiceto (BO - Italy) in the heart of Emilia Romagna, historic cradle for state-of-the-art companies in the world of motors and mechanical engineering.

Neri Motori were founded as electrical motor manufacturers and on the strength of their experience matured in over half a century of activity, today they are acknowledged among the leading companies in the sector.

Thanks to constant positive interaction with the customers, today the company is recognized as ideal partners, not only for common applications but for complex industrial projects too.

The range of application for our motors is transversal: ranging from simple combinations with reduction gears, to high-tech applications like drying systems, machines for ceramics production, machines for producing yarns, industrial mixers, and applications in wind turbines. So many possibilities, and a single partner to satisfy all your requirements.

You are invited to analyze and develop your applications taking advantage of the know-how that sets us apart: this is what makes Neri Motori the ideal partners for all your projects.

## Technology at the service of customers

Our idea of quality extends well beyond the products we produce, and for us it also embraces a series of dedicated services for our present and future customers.

We help you design and then develop your application, from the simplest to the most complex, passing on our know-how and offering you the advantage of our decades of experience.

We offer a series of instruments ranging from WebOrder with the possibility of checking the availability of motors in stock at the warehouse, to downloads of our product drawings in 2D and 3D, to the new RMA instrument designed to facilitate and simplify the exchange of information between your company and Neri Motori.

All these services, combined with our professionalism and skills in the sector, make Neri Motori the ideal partners.

## WEB ORDER: YOUR DOOR TO THE NERI MOTORI WORLD

A portal dedicated to our customers where you will find all the information you need with a simple mouse click: availability of motors in stock, status of your orders underway, download our products drawings in 2D and 3D, and a dedicated customer care service to maintain high service quality standards, and help get to know our customers' needs and expectations. standard di qualità del servizio, conoscere i bisogni e le aspettative dei nostri clienti.



Web Order



Magnetic core **1**

Dynamic balanced rotor **2**

Bearings guarantee - 2RS - C3 / Locked over size 180 **3**  
With greaser from size 180

For vertical mounting. Upon request special bearings from 160 size **4**

Large voltage range:  
230/400/50 Hz - 280/480/60 Hz (up to 132 size) **5**  
400/690/50 Hz - 480/830/60 Hz (from 132 size)  
Other version upon request

Versions: B3 - B5 - B14 - B3/B14 - B3/B5 **6**

IP 55. Other protections available upon request **7**





**8** S1/Class F. Other insulations available upon request

**9** Inverter duty (standard)

**10** 3 PTC standard from size 160,  
upon request on other size

**11** IEC 34-1 (standard)  
CEI/IEC 72-1 (standard)

**12** Removable feet to 132 included

**13** Alluminium body from size 56 ÷ 132  
Cast iron body from size 160 ÷ 355

**14** MR IE2 series High efficiency induction motors

**15** Forced ventilation and encoder upon request



## The Certification of the company quality system conforms to ISO 9001 Standards (2000)

In line with company quality POLEScy, NERI MOTORI is Certified conforming to ISO 9001 Standards (2000). The effort made in achieving this goal has resulted in constant improvements in product and Customer service. The management's willingness to keep the Company at worldwide competitive levels has triggered a worthy process of improvement, in all the Company's activities, with constant CUSTOMER SATISFACTION monitoring. This has been achieved thanks to investments made in the training of personnel, in the design and in the investments of machines and state-of-the-art technologies for tests at the initial stages, during production and during the final stage.

## Marking

EUROPEAN STANDARD

Per the provisions of the Machine Directive 89/392/EEC, the electric motor is a component that may not cause hazards to people, animals or property.

The following directives are applied to this end:

- 1) Low Voltage 2006/95/CE, according to which the electric motor is "low-voltage electrical material";
- 2) Electromagnetic Compatibility 89/336/EEC.
- 3) 98/37/CE\*

In compliance with these directives, type tests were carried out on Neri standard production; in particular, European Standard EN-60204-1 was applied for safety purposes.

The European Standard EN-55014 (1994) was applied for EMC, carrying out:

- a) Guided peak tests in the 150 KHz - 30 MHz frequency range,
- b) Radiated tests in the 30 MHz-1 GHz frequency range.

All of the production passed the tests or was modified to do so.

The corresponding documentation is available from our headquarters and may be supplied upon request.

\* upon request

## ATEX Motors - 94/9/CE

Neri Motori designs, produces, and self-certifies ATEX Motors for zone 2 zone 22.

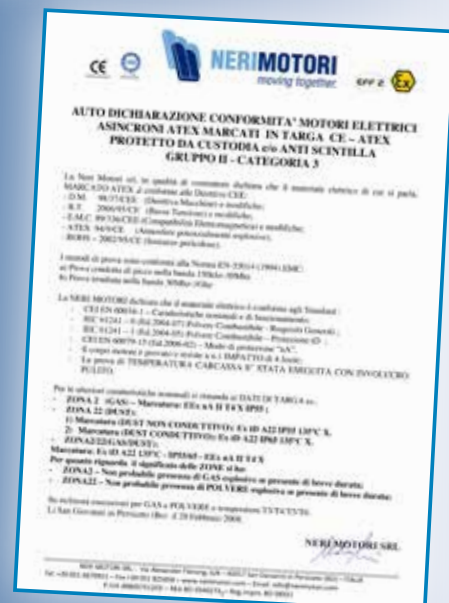
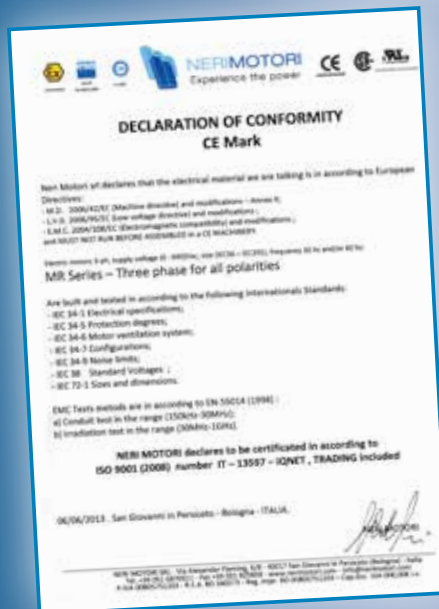

## Standard production reference standards

Standards	IEC (World)	CENELEC (Europe)	CEI (Italy)	UNEL (Italy)	DIN (Germany)	VDE (Germany)	BS (U.K.)	NFC (France)
<b>Electrical specifications</b>	IEC 34-1	HD 53.1.S2	CEI EN 60034-1			VDE 0530T1	BS 2613 5000	NFC 51-100 51-120
<b>Protection class</b>	IEC 34-5	EN 60034-5	CEI EN 60034-5	UNEL 05515	DIN 40050	VDE 0530	BS 4999-20	NFC 51-115
<b>Motor ventilation system</b>	IEC 34-6	EN 60034-6			DIN IEC 34-6		BS 4999-21	
<b>Configurations</b>	IEC 34-7	HD 53.7	CEI EN 60034-7	UNEL 05513	DIN 42950			NFC 51-117
<b>Noise limits</b>	IEC 34-9		CEI EN 60034-9					
<b>Standardized voltages</b>	IEC 38		CEI 8-6					NFC 6
<b>Sizes and dimensions</b>	IEC 72-1		CEI IEC 72-1	UNEL 13113 13117 13118	DIN 42673 42677 42946		BS 3979	NFC 51-105 51-120
<b>Machinery safety electric equipment of the machines</b>			CEI EN 60204-1					

## The Certification of the company quality system conforms

<b>ISO 9001 (2000)</b>	Model for quality assurance in design, project, construction, trading, assistance of electric motors
<b>UNI EN 30012</b>	Metrological confirmation system for measuring equipment



<b>89/392 CE*</b>	Machines directives - MD
<b>73/23 CE</b>	Low voltage directive - LVD
<b>89/336 CEE</b>	Electromagnetic compatibility directive - EMC
<b>ROHS - 2002/95/CE</b>	Dangerous Substances Directive

\* upon request

### USAGE

- Unless otherwise specified, this manual uses I.S. International System units of measure (meter, kilogram, second, ampere).
- Lengths are in mm. in all size tables.
- The terminal covers in the overall dimensions drawings are the double ones (IP65).

## Technical specifications

The electric motors covered by this catalogue are constructed and tested in accordance with the IEC Norms which implement the most important EEC European Directives in the electrical engineering sector.

All the induction motors we produce have die-cast squirrel cage motor and wound stator, are enclosed and have external cooling to IEC 34-6 (IC 411).

**The power supply voltages** of the standard motors in the catalogue comply with IEC 38 (1983) and CEI-8-6 (March 1990): 230V/400V/50Hz for the three-phase models with permissible variation of  $\pm 10\%$  of the rated voltage.

All electrical and mechanical specifications, as well as the testing methods, comply with IEC 34-1 and CEI EN 60034-1.

**The output powers** and machine sizes comply with CEI IEC 72-1, while construction forms B3, B5 and B14 are to IEC 34-7.

All geometrical dimensions are standardized in accordance with the UNEL tables 13113-71, 13117-71, 13118-71/CEI IEC 72-1.

**The degrees of protection** of the casings comply with CEI EN 60034-5. Our standard motors have IP 55 protection and are insulated overall in class F to IEC 34-1 and CEI EN 60034-1.

As standard, **the drive shafts** and tangs have dimensions and tolerances to CEI IEC 72-1.

Standard shafts are constructed in C43/C40 steel.

We use preloaded **bearing** rings of the best makes, which our company considers reliable.

**Motors** are manufactured for standard S1 service, other executions on request.

## Mechanical specifications

### Wound Stators

High-quality magnetic sheet metals are used for most of the production, to ensure constant high performance.

The copper used is impregnated with a double layer of insulating enamel to ensure high resistance to electrical, thermal and mechanical stress.

The standard insulation class of the motor is F, may be supplied upon

agreement with the manufacturer.

Max. ambient temperature considered is 40 °C.

Tropicalization processes are available through impregnation with paints having high hygroscopic qualities, for use in areas with high ambient humidity >60% R.H.

### Rotors (tropicalized)

These are die-cast alluminium squirrel-cage rotors.

### Keys

These are made of C40 steel with dimensions standardized per CEI IEC 72-1. The thread diameters of standard shafts, in compliance with standard DIN 332. Body according CEI-IEC 72-1.

### Frame (per CEI-IEC 72-1)

Die-cast alluminium with high mechanical capacity, good thermal conductivity, and very lightweight.

Frames are available in a version with standard tie-rods, with studs upon request.

### Motor terminal board

For the B3 frame with feet, the terminal board is placed on top in standard production, or may be placed on the right or left side upon request.

### Flanges and shields (per CEI-IEC 72-1)

Standard dimensions per CEI-IEC 72-1.

From size 56 to 132 are in alluminium, while from size 160 to 355 cast iron.

### Cooling (per IEC 34-6 and EN 60034-6)

Obtained by means of a two-way rotary fan with radial blades keyed onto the motor shaft IC 411.

Made of plastic, it has a high operating temperature.

For applications with electronic controls such as inverters, assisted power cooling is available via an auxiliary cooling-type motor IC416, also in kit form.

### Fan cover

Galvanized sheet metal.

### Noise level (CEI EN 60034-9)

Sound pressure and power levels were measured on single- and three-phase motors, one meter away from the machine, and weighted according to curve A (ISO R 1680). At 50 Hz for relative values at 60 Hz, this increases by an average of 4 dbA.

### Mechanical tolerances (per CEI-IEC 72-1)

Table shows the mechanical tolerances where the motor is keyed with the load.

Description	Dimension	Tolerance	
Shaft diameter	D	$\leq \varnothing 28$ mm	j6
		$\varnothing 32$ mm $\div$ $\varnothing 48$ mm	k6
		$\varnothing 55$ mm $\div$ $\varnothing 110$ mm	m6
CEI IEC 72-1 Standardized keys	F		h9
		G	2 mm $\div$ 6 mm
			7 mm $\div$ 16 mm
CEI IEC 72-1 Standardized flanges	N	$\leq \varnothing 450$ mm	j6
Axis height per CEI IEC 72-1	H	+0 $\div$ -0.5 mm	
Shaft stop	E	+0 $\div$ -0.2 mm	



## Available configurations (to specify when ordering)

The table shows the available motor configurations and installation positions per IEC 34-7. Versions B3, B5, B14.

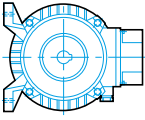
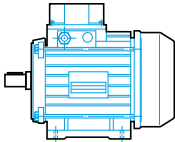
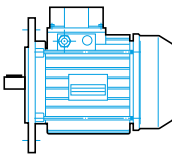
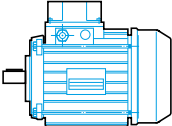
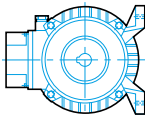
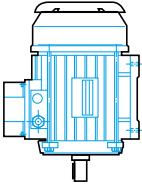
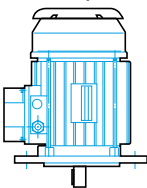
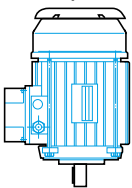
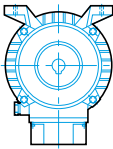
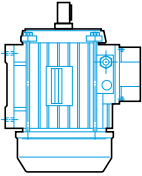
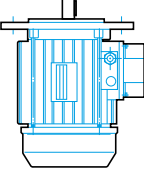
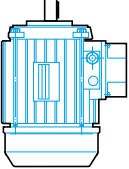
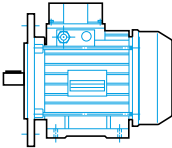
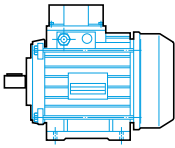
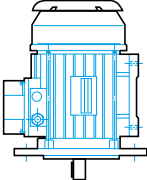
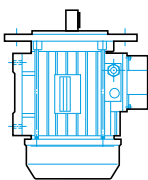
Motors with feet B3		Flange-mounted B5	Flange-mounted motors B14
<p>IM 1051 (IM B6)</p> 	<p>IM 1001 (IM B3)</p> 	<p>IM 3001 (IM B5)</p> 	<p>IM 3601 (IM B14)</p> 
<p>IM 1061 (IM B7)</p> 	<p>IM 1011 (IM V5)</p> 	<p>IM 3011 (IM V1)</p> 	<p>IM 3611 (IM V18)</p> 
<p>IM 1071 (IM B8)</p> 	<p>IM 1031 (IM V6)</p> 	<p>IM 3031 (IM V3)</p> 	<p>IM 3631 (IM V19)</p> 
<p>IM 2001 (IM B35)</p>  <p>B3/B5</p>	<p>IM 2101 (IM B34)</p>  <p>B3/B14</p>	<p>IM 2011 (IM V15)</p>  <p>V1/V5</p>	<p>IM 2031 (IM V36)</p>  <p>V3/V6</p>

## IP ratings and housings

IP55 standard protection rating of the motors.

Special executions are possible for harsh environments with greater or specific protection except for other indications on motor rating plate.

## Terminalbox position

In the motors from size 56 to 132 there is the possibility to change the position of the feet as they are fixed with 2 screws. In case the feet are laterally fixed it's also possible to change the position of the terminal box at left or right side. It's also possible to change the mounting position in B3/B5 or in B3/B14.

## Bearings

Bearings are pre-lubricated to IEC 160 with grease with a temperature range from -10°C till +110°C.

Can be applied bearings with special grease for high temperatures (-30°C to +140°C) / synthetic grease.

All are pre-loaded with corrugated tempered steel rings to eliminate residual clearance from the bearing.

Bearings					
Size	Poles	Cast iron		Alluminium	
		Shaft side	Fan side	Shaft side	Fan side
56	2 - 8	-	-	6201 2RS	6201 2RS
63	2 - 8	-	-	6201 2RS	6201 2RS
71	2 - 8	-	-	6202 2RS	6202 2RS
80	2 - 8	-	-	6204 2RS	6204 2RS
90	2 - 8	-	-	6205 2RS	6205 2RS
100	2 - 8	-	-	6206 2RS	6206 2RS
112	2 - 8	-	-	6306 2RS	6306 2RS
132	2 - 8	-	-	6308 2RS	6308 2RS
160	2	6209 C3	6208 C3	-	-
	4 - 8	6309 C3	6209 C3	-	-
180	2	6211 C3	6211 C3	-	-
	4 - 8	6311 C3	6211 C3	-	-
200	2	6212 C3	6212 C3	-	-
	4 - 8	6312 C3	6212 C3	-	-
225	2	6312 C3	6312 C3	-	-
	4 - 8	6313 C3	6312 C3	-	-
250	2	6313 C3	6313 C3	-	-
	4 - 8	6314 C3	6313 C3	-	-
280	2	6314 C3	6314 C3	-	-
	4 - 8	6317 C3	6314 C3	-	-
315	2	6317 C3	6317 C3	-	-
	4 - 10	N319	6319 C3	-	-
355	2	6319 C3	6319 C3	-	-
	4 - 10	N322	6322 C3	-	-

For vertical mounting ask Neri Motori. Bearing series NU upon request from size 160 to 280

Oil seal					
Size	Poles	Cast iron		Alluminium	
		Shaft side	Fan side	Shaft side	Fan side
56	2 - 8	-	-	12 x 22 x 5	12 x 22 x 5 *
63	2 - 8	-	-	12 x 24 x 7	12 x 24 x 7 *
71	2 - 8	-	-	15 x 18 x 7	15 x 28 x 7 *
80	2 - 8	-	-	20 x 34 x 7	20 x 34 x 7 *
90	2 - 8	-	-	25 x 37 x 7	25 x 37 x 7 *
100	2 - 8	-	-	30 x 44 x 7	30 x 44 x 7 *
112	2 - 8	-	-	30 x 44 x 7	30 x 44 x 7 *
132	2 - 8	-	-	40 x 58 x 8	40 x 58 x 8 *
160	2 - 8	45 x 62 x 8	45 x 62 x 8	-	-
180	2 - 8	55 x 72 x 12	55 x 72 x 12	-	-
200	2 - 8	60 x 75 x 8	60 x 75 x 8	-	-
225	2	60 x 75 x 8	60 x 75 x 8	-	-
	4 - 8	65 x 85 x 12	65 x 85 x 12	-	-
250	2	65 x 85 x 12	65 x 85 x 12	-	-
	4 - 8	70 x 90 x 12	65 x 85 x 12	-	-
280	2	70 x 90 x 12	70 x 90 x 12	-	-
	4 - 8	85 x 100 x 12	85 x 100 x 12	-	-
315	2	85 x 110 x 12	85 x 110 x 12	-	-
	4 - 10	95 x 120 x 12	95 x 120 x 12	-	-
355	2	95 x 120 x 12	95 x 120 x 12	-	-
	4 - 10	95 x 130 x 12	95 x 130 x 12	-	-

\* Vring Standard - Oil seal upon request

## Electrical specifications

### Stator winding insulation (per EN 60034-1 and IEC 34-1)

Top quality insulating materials are used in the windings.

Max. ambient temperature considered is 40°C.

The motor has an overall standard temperature insulation rating of class F. In standard configurations, the copper wire is insulated by a double layer of insulating enamel.

Insulation in slot, between copper and iron, is achieved with a film that wraps completely the coil side.

In all the motors the phases are insulated between each other with an extra

film, which protects from possible tension peaks that could happen during working under inverter.

Once the winding is finished, it is further impregnated with insulating paint and hardened by kiln firing to compact the entire unit, providing high resistance to electrical, mechanical and chemical stress.

Below is a graph showing the operating temperatures possible for stator windings based on the insulation rating shown on the machine plate.

### Insulation

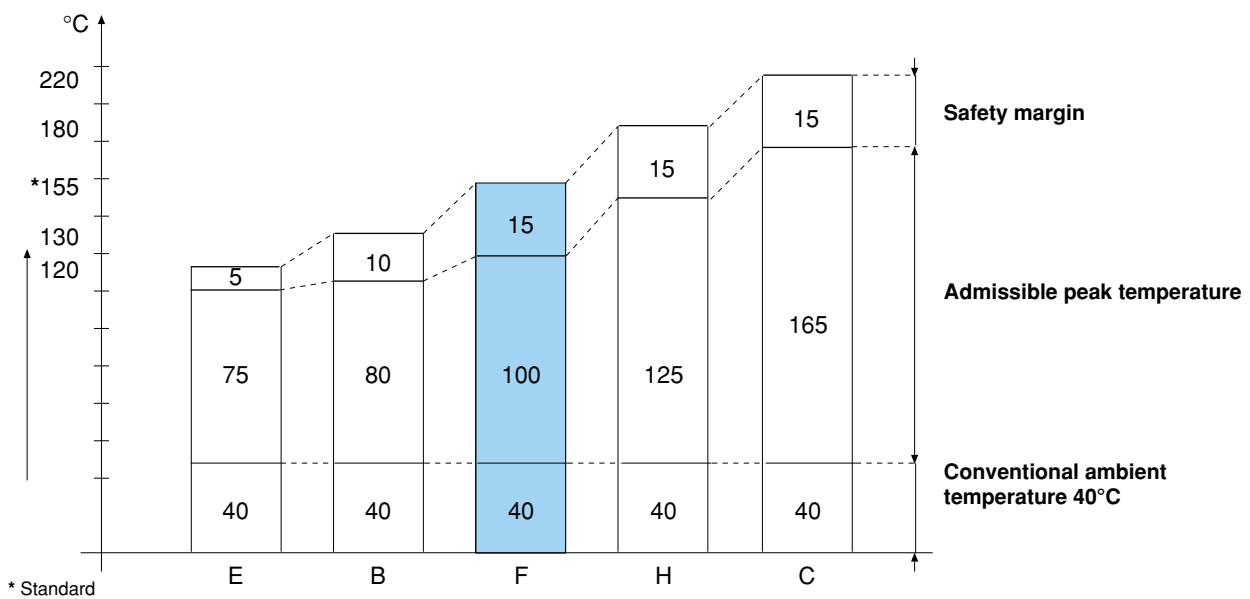

### Voltages and frequencies (per CEI EN 60034-1)

Neri three-phase and single phase motors can run at a voltage different from the rated one, with a margin of  $\pm 10\%$  short term (performance variations are possible and more significant for the single phase).

### CEI EN 60034-1

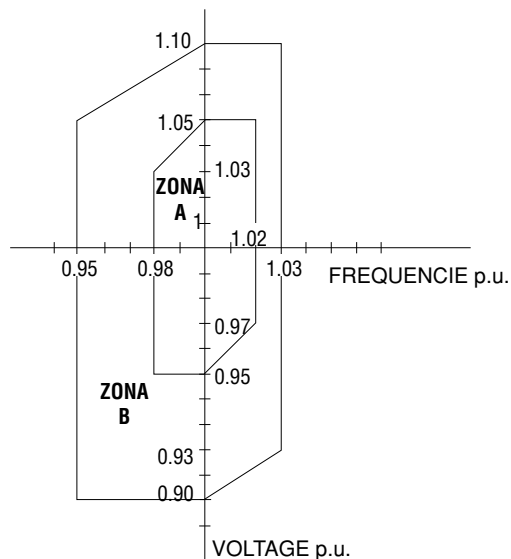

**ZONE A:** Normal duty

**ZONE B:** Heavy service limited over time

**POINT 1:** Main function guaranteed (nominal torque)

The table below shows the voltages at which a motor manufactured at the rated voltage may correctly run (information given are only indicative, please refer to motor type plate).

Ask NERI MOTORI for voltages not listed.

Rated voltages [V] [Hz]		Usable voltages [V] [Hz] (Zone A - Tab. 11)
230/400/50	277/480/60	240/415/50 - 220/380/50 - 265/460/60 - 255/440/60
190/330/50	220/380/60	200/346/60 - 208/360/60 - 230/400/60
208/360/50	254/440/60	200/346/50 - 240/415/60
400/690/50	480/830/60	380/660/50 - 415/717/50

### Frequencies at 60 Hz

All electrical data in this catalogue refer to three-phase motors wound at 50 Hz.

These may be connected to 60 Hz, taking into account the multiplier coefficients in the table below:

Rated voltage at 50 Hz	Volt at 60 Hz	Rated power W	rpm	In	Ia / In	Ca / Cn	Cmax / Cn
220	220	1,00	1,2	1,20	0,80	0,80	0,80
220	230	1,05	1,2	1,15	0,85	0,85	0,85
220	240	1,06	1,2	1,10	0,87	0,87	0,87
* 230	230	1,00	1,2	1,20	0,80	0,80	0,80
230	240	1,10	1,2	1,15	0,90	0,90	0,90
230	260	1,20	1,2	1,00	1,00	1,00	1,00
* 400	400	1,00	1,2	1,20	0,80	0,80	0,80
400	440	1,06	1,2	1,10	0,87	0,87	0,87
400	460	1,20	1,2	1,00	1,00	1,00	1,00
400	480	1,25	1,2	1,00	1,10	1,10	1,10
440	440	1,00	1,2	1,20	0,80	0,80	0,80
500	500	1,00	1,2	1,20	0,80	0,80	0,80
500	550	1,06	1,2	1,10	0,87	0,87	0,87

Where you can notice\* that a motor wound at 50 Hz can work at 60 Hz with the same rated voltage, power (W), with a 1,2 increase of rpm and rated current and, also a 0,8 reduction of starting current Ia / In, of the starting torque Ca / Cn and of the maximum torque Cmax / Cn.

### Legend

**rpm** = R.p.m.

**Is / In** =  $\frac{\text{Starting current}}{\text{Rated current}}$

**Cs / Cn** =  $\frac{\text{Starting torque}}{\text{Rated torque}}$

**Cmax / Cn** =  $\frac{\text{Maximum torque}}{\text{Rated torque}}$

**In** = Rated current

### Three-phase connection diagram

Star connection

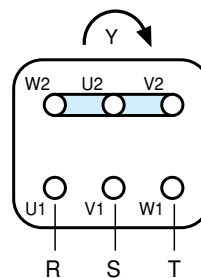

Delta connection

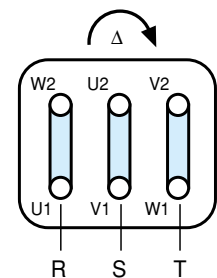



## THREE-PHASE INDUCTION MOTORS MR E MR IE2 TYPES

The asynchronous three-phase have been specifically designed with use at variable speed, torque and power. It has therefore been possible to achieve excellent results in terms of limited temperature and high performance even when controlled by inverter thanks to the use of high-quality materials.

Motors are painted.

Motors painted RAL 9006 up to size IEC132 and RAL5010 from size IEC160.

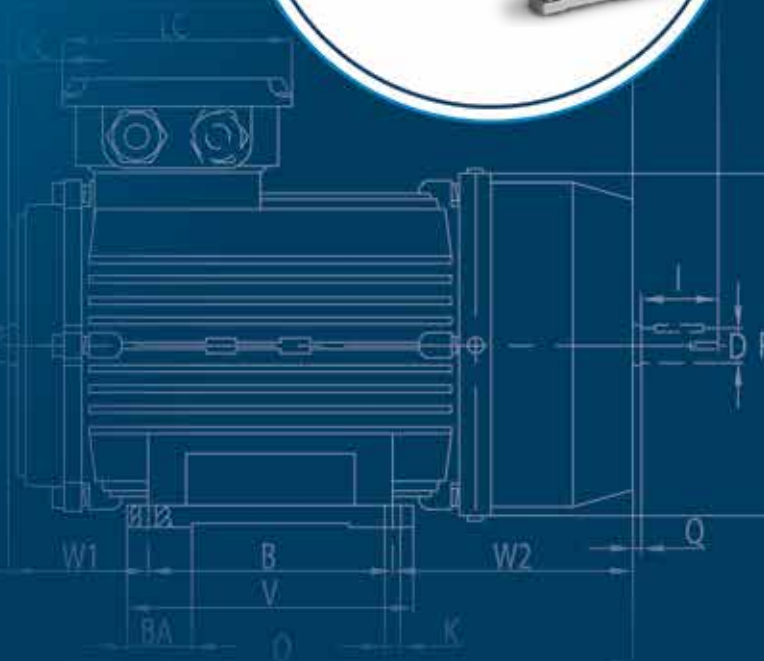

## 2 POLES 3000 rpm

Size	Power		Rpm	In (A)	Is / In	Cn (Nm)	Cs / Cn	Cmax / Cn	Rend. % $\eta$	Cos $\phi$ %	Weight kg	J Kgm <sup>2</sup>
	kW	HP										
<b>Alluminium motors - Volt 230/400/50 Hz</b>												
56A	0,09	0,12	2758	0,32	6,0	0,31	2,3	2,4	59,0	0,68	3,2	0,000180
56B	0,12	0,18	2780	0,36	6,0	0,41	2,3	2,4	67,0	0,71	3,4	0,000230
63A	0,18	0,25	2715	0,50	6,0	0,63	2,2	2,4	69,0	0,75	4,0	0,000310
63B	0,25	0,37	2715	0,65	6,0	0,88	2,2	2,4	68,0	0,81	4,5	0,000300
63C	0,37	0,50	2715	0,94	6,0	1,30	2,5	2,7	70,0	0,81	5,5	0,000350
71A	0,37	0,50	2690	0,90	6,0	1,31	2,2	2,4	70,0	0,81	6,0	0,000750
71B	0,55	0,75	2740	1,33	6,0	1,93	2,2	2,3	73,0	0,82	6,5	0,000900
71C	0,75	1,00	2700	1,81	6,0	2,65	2,6	2,9	75,0	0,83	8,3	0,000570
80A	0,75	1,00	2730	1,66	6,0	2,62	2,2	2,4	75,0	0,83	9,3	0,001200
80B	1,10	1,50	2746	2,42	6,0	3,83	2,2	2,4	77,0	0,84	10,0	0,001400
80D	1,50	2,00	2770	3,23	6,0	5,17	2,8	3,1	79,0	0,84	11,5	0,001200
90S	1,50	2,00	2715	3,65	6,0	5,28	2,2	2,4	79,0	0,84	14,0	0,002900
90L	2,20	3,00	2772	4,65	6,0	7,58	2,2	2,4	81,0	0,85	16,0	0,005500
90LB	3,00	4,00	2800	6,10	6,0	10,20	3,0	3,2	83,0	0,87	18,5	0,001900
100L	3,00	4,00	2870	6,10	7,0	10,00	2,2	2,3	83,0	0,87	21,0	0,010900
100LB	4,00	5,50	2880	7,93	7,0	13,30	2,5	2,7	85,0	0,88	26,0	0,008500
112M	4,00	5,50	2890	7,93	7,0	13,20	2,5	2,7	85,0	0,88	27,0	0,012600
112MB	5,50	7,50	2900	10,84	7,0	18,10	2,5	2,7	86,0	0,88	30,0	0,012000
132SA	5,50	7,50	2910	10,45	7,5	18,00	2,5	2,7	86,0	0,88	39,0	0,037700
132SB	7,50	10,00	2900	14,25	7,5	24,70	2,5	2,7	87,0	0,88	44,0	0,049900
132ML	9,20	12,50	2910	17,70	7,5	30,20	2,5	2,7	87,5	0,89	51,0	0,015100
132MV	11,00	15,00	2919	21,14	7,5	36,00	2,5	2,7	88,0	0,89	55,5	0,028000
<b>Cast iron motors - Volt 400/690/50 Hz</b>												
160MA	11,0	15,00	2950	21,30	8,0	35,60	2,0	2,2	88,0	0,88	106,0	0,037700
160MB	15,0	20,00	2970	28,70	8,0	48,20	2,0	2,2	89,0	0,89	107,0	0,049900
160L	18,5	25,00	2970	34,60	8,0	59,50	2,0	2,2	90,0	0,90	117,0	0,055000
180M	22,0	30,00	2970	40,90	8,0	70,70	2,0	2,2	90,5	0,90	152,0	0,075000
200LA	30,0	40,00	2970	55,40	8,0	96,50	2,0	2,2	91,2	0,90	220,0	0,124000
200LB	37,0	50,00	2980	67,70	8,0	118,60	2,0	2,2	92,0	0,90	230,0	0,139000
225M	45,0	60,00	2980	82,30	8,0	144,20	1,8	2,2	92,3	0,90	252,0	0,233000
250M	55,0	75,00	2980	101,00	7,0	176,30	1,8	2,2	92,5	0,90	366,0	0,312000
280S	75,0	100,00	2980	134,00	7,0	240,40	1,8	2,2	93,0	0,90	475,0	0,579000
280M	90,0	125,00	2980	160,00	7,0	288,40	1,8	2,2	93,8	0,91	530,0	0,675000
315S	110,0	150,00	2980	195,00	6,8	352,51	1,8	2,2	94,0	0,91	850,0	1,800000
315M	132,0	180,00	2980	233,00	6,8	423,00	1,8	2,2	94,5	0,91	930,0	1,820000
315LA	160,0	220,00	2980	279,00	6,8	512,80	1,8	2,2	94,6	0,92	990,0	2,080000
315LB	200,0	270,00	2980	348,00	6,8	640,94	1,8	2,2	94,8	0,92	1030,0	2,380000
355M	250,0	340,00	2980	433,00	7,0	801,20	1,6	2,2	95,3	0,92	1650,0	3,000000
355L	315,0	430,00	2980	544,00	7,0	1009,50	1,6	2,2	95,6	0,92	1750,0	3,500000

## 4 POLES 1500 rpm

Size	Power		Rpm	In (A)	Is / In	Cn (Nm)	Cs / Cn	Cmax / Cn	Rend. % $\eta$	Cos $\phi$ %	Weight kg	J Kgm <sup>2</sup>
	kW	HP										
<b>Alluminium motors - Volt 230/400/50 Hz</b>												
56A	0,06	0,09	1371	0,27	6,0	0,42	2,3	2,4	46,0	0,56	3,0	0,00030
56B	0,09	0,12	1350	0,37	6,0	0,64	2,3	2,4	49,0	0,56	3,4	0,00040
63A	0,12	0,18	1350	0,46	6,0	0,85	2,2	2,4	53,0	0,64	3,5	0,00050
63B	0,18	0,25	1340	0,62	6,0	1,28	2,2	2,4	56,0	0,66	4,9	0,00060
63C	0,22	0,30	1350	0,75	6,0	1,77	2,2	2,4	65,0	0,74	5,5	0,00040
71A	0,25	0,37	1390	0,79	6,0	1,72	2,2	2,4	65,0	0,74	6,0	0,00080
71B	0,37	0,50	1330	1,06	6,0	2,57	2,2	2,4	67,0	0,75	6,4	0,00130
71C	0,55	0,75	1380	1,40	6,0	3,81	2,2	2,4	71,0	0,75	7,5	0,00090
80A	0,55	0,75	1370	1,48	6,0	3,83	2,2	2,4	71,0	0,75	9,0	0,00180
80B	0,75	1,00	1380	1,91	6,0	5,19	2,2	2,4	73,0	0,76	10,5	0,00210
80D	1,10	1,50	1380	2,75	6,0	7,61	2,3	2,5	75,0	0,77	11,5	0,00330
90S	1,10	1,50	1390	2,61	6,0	7,56	2,2	2,4	75,0	0,77	13,5	0,00230
90L	1,50	2,00	1400	3,47	6,0	10,20	2,2	2,4	78,0	0,79	16,0	0,00270
90LB	1,80	2,40	1400	4,33	6,0	12,60	2,2	2,4	78,0	0,79	17,0	0,00324
90LBB	2,20	3,00	1400	4,90	6,0	15,00	2,5	2,7	80,0	0,81	18,0	0,00396
100LA	2,20	3,00	1430	4,75	7,0	14,70	2,2	2,3	80,0	0,81	20,0	0,00540
100LB	3,00	4,00	1430	6,46	7,0	20,00	2,2	2,3	82,0	0,82	24,0	0,00670
100BL	4,00	5,50	1420	8,38	7,0	26,90	2,5	2,7	84,0	0,82	29,0	0,00893
112M	4,00	5,50	1430	8,36	7,0	26,70	2,2	2,3	84,0	0,82	30,5	0,00950
112MB	5,50	7,50	1435	11,25	7,0	36,60	2,7	3,0	85,0	0,83	41,0	0,01600
132S	5,50	7,50	1440	11,40	7,0	36,50	2,2	2,2	82,0	0,83	44,0	0,02140
132M	7,50	10,00	1450	14,80	7,0	49,40	2,2	2,2	87,0	0,84	54,5	0,02960
132MLA	9,20	12,30	1460	18,07	7,0	60,20	2,7	3,0	87,5	0,84	62,0	0,03630
132MLB	11,00	15,00	1460	21,20	7,0	72,00	2,5	2,7	88,0	0,85	66,0	0,04340
<b>Cast iron motors - Volt 400/690/50 Hz</b>												
160M	11,00	15,00	1460	22,30	7,0	72,00	2,0	7,0	88,0	0,85	106,0	0,07470
160L	15,00	20,00	1460	30,00	7,0	98,10	2,0	7,0	89,0	0,85	126,0	0,09180
180M	18,50	25,00	1470	36,40	7,5	120,20	2,2	2,2	90,5	0,85	154,0	0,13900
180L	22,00	30,00	1470	43,10	7,5	142,90	2,2	2,2	91,0	0,85	175,0	0,15800
200L	30,00	40,00	1470	57,40	7,5	194,90	2,2	2,2	92,0	0,86	235,0	0,26200
225S	37,00	50,00	1480	69,90	7,5	238,80	2,2	2,2	92,5	0,87	295,0	0,40600
225M	45,00	60,00	1480	84,70	7,5	290,40	2,2	2,2	92,8	0,87	306,0	0,46900
250M	55,00	75,00	1480	103,00	7,0	354,90	2,2	2,2	93,0	0,89	375,0	0,66000
280S	75,00	100,00	1480	140,00	7,0	484,00	2,2	2,2	93,8	0,86	533,0	1,12000
280M	90,00	125,00	1490	167,00	7,0	580,70	2,2	2,2	94,2	0,86	575,0	1,46000
315S	110,00	150,00	1490	201,00	6,9	705,00	2,1	2,2	94,5	0,87	820,0	3,11000
315M	132,00	180,00	1490	240,00	6,9	846,00	2,1	2,2	94,8	0,87	960,0	3,62000
315LA	160,00	220,00	1490	287,00	6,9	1024,50	2,1	2,2	94,9	0,88	1000,0	4,13000
315LB	200,00	270,00	1490	359,00	6,9	1281,90	2,3	2,2	95,0	0,88	1080,0	4,73000
355M	250,00	340,00	1485	443,00	6,8	1607,70	2,3	2,2	95,3	0,88	1580,0	6,50000
355L	315,00	430,00	1485	556,00	6,9	2025,80	2,2	2,2	95,6	0,89	1730,0	8,20000

**6 POLES 1000 rpm**

Size	Power		Rpm	In (A)	Is / In	Cn (Nm)	Cs / Cn	Cmax / Cn	Rend. % η	Cosφ %	Weight kg	J Kgm <sup>2</sup>
	kW	HP										
<b>Alluminium motors - Volt 230/400/50 Hz</b>												
63B	0,18	0,25										
71A	0,18	0,25	880	0,7	6,0	1,95	2,2	2,4	59,0	0,63	5,9	0,001100
71B	0,25	0,37	900	0,9	6,0	2,65	2,2	2,4	59,0	0,68	6,3	0,001400
71C	0,37	0,50	900	1,3	6,0	3,93	2,2	2,4	62,0	0,70	7,5	0,002100
80A	0,37	0,50	915	1,2	6,0	3,86	2,2	2,4	62,0	0,70	8,9	0,001600
80B	0,55	0,75	920	1,7	6,0	5,71	2,2	2,4	65,0	0,72	9,3	0,001900
90S	0,75	1,00	930	2,2	5,5	7,70	2,2	2,2	69,0	0,72	12,0	0,002900
90L	1,10	1,50	930	3,0	5,5	11,30	2,2	2,2	72,0	0,73	16,0	0,003500
100L	1,50	2,00	945	3,8	6,0	15,20	2,2	2,2	76,0	0,75	20,0	0,006900
112M	2,20	3,00	945	5,3	6,0	22,20	2,2	2,2	79,0	0,76	26,5	0,014000
132S	3,00	4,00	960	6,8	6,5	29,80	2,0	2,0	81,0	0,76	43,0	0,028600
132MA	4,00	5,50	960	8,9	6,5	39,80	2,0	2,0	82,0	0,76	46,5	0,035700
132MB	5,50	7,50	960	12,3	6,5	54,71	2,0	2,0	84,0	0,77	54,0	0,044900

<b>Cast iron motors - Volt 400/690/50 Hz</b>												
160M	7,50	10,00	970	16,5	6,5	73,84	2,0	2,0	86,0	0,80	114,0	0,081000
160L	11,00	15,00	970	24,1	6,5	108,30	2,0	2,0	87,5	0,79	121,0	0,116000
180L	15,00	20,00	970	31,5	7,0	147,68	2,0	2,0	89,0	0,81	162,0	0,207000
200LA	18,50	25,00	970	38,5	7,0	182,14	2,0	2,0	90,0	0,81	209,0	0,315000
200LB	22,00	30,00	970	44,6	7,0	216,60	2,0	2,0	90,0	0,83	226,0	0,360000
225M	30,00	40,00	980	59,3	7,0	292,35	2,0	2,0	91,5	0,84	273,0	0,547000
250M	37,00	50,00	980	71,0	7,0	360,26	2,0	2,1	92,0	0,86	360,0	0,843000
280S	45,00	60,00	980	86,0	7,0	438,52	2,0	2,0	92,5	0,86	494,0	1,390000
280M	55,00	75,00	980	105,0	7,0	536,00	2,0	2,0	92,8	0,86	517,0	1,650000
315S	75,00	100,00	990	141,0	7,0	723,50	2,0	2,0	93,5	0,86	770,0	4,110000
315M	90,00	125,00	990	169,0	7,0	868,20	2,0	2,0	93,8	0,86	840,0	4,780000
315LA	110,00	150,00	990	206,0	6,7	1061,10	2,0	2,0	94,0	0,86	990,0	5,450000
315LB	132,00	180,00	990	244,0	6,7	1273,30	2,0	2,0	94,2	0,87	1040,0	6,120000
355MA	160,00	220,00	990	292,0	6,7	1543,40	1,9	2,0	94,5	0,88	1470,0	9,500000
355MB	200,00	270,00	990	365,0	6,7	1929,30	1,9	2,0	94,7	0,88	1640,0	10,400000

**8 POLES 750 rpm**

<b>Alluminium motors - Volt 230/400/50 Hz</b>												
80A	0,18	0,25	680	0,93	6,0	2,53	2,2	2,4	51,0	0,55	9,0	0,002500
80B	0,25	0,37	680	1,15	6,0	3,50	2,2	2,4	54,0	0,61	11,0	0,003000
90S	0,37	0,50	680	1,49	6,0	5,20	2,2	2,4	62,0	0,61	14,0	0,005100
90L	0,55	0,75	700	2,17	6,0	7,50	2,2	2,4	63,0	0,61	17,0	0,006500
100LA	0,75	1,00	700	2,40	6,0	10,20	2,2	2,3	71,0	0,67	19,0	0,009500
100LB	1,10	1,50	710	3,30	6,0	14,80	2,2	2,3	73,0	0,69	20,0	0,011000
112M	1,50	2,00	710	4,30	6,0	20,20	2,2	2,3	75,0	0,69	27,0	0,024500
132S	2,20	3,00	720	5,51	6,0	29,20	2,0	2,0	78,0	0,71	36,0	0,031400
132M	3,00	4,00	720	7,32	5,5	39,80	2,0	2,0	79,0	0,73	43,0	0,039500

<b>Cast iron motors - Volt 400/690/50 Hz</b>												
160MA	4,00	5,50	720	10,20	6,0	53,10	2,0	2,0	81,0	0,73	112,0	0,075300
160MB	5,50	7,50	720	13,60	6,0	73,00	2,0	2,0	83,0	0,74	113,0	0,093100
160L	7,50	10,00	720	17,70	6,0	99,50	2,0	2,0	85,5	0,75	140,0	0,126000
180L	11,00	15,00	730	25,10	6,0	143,90	2,0	2,0	87,5	0,76	166,0	0,203000
200L	15,00	20,00	730	34,00	6,5	196,23	2,0	2,0	88,0	0,76	214,0	0,399000
225S	18,50	25,00	740	40,60	6,6	238,80	1,9	2,0	90,0	0,76	255,0	0,491000
225M	22,00	30,00	740	47,40	6,6	283,90	1,9	2,0	90,5	0,78	284,0	0,547000
250M	30,00	40,00	740	64,00	6,6	387,20	1,9	2,0	91,0	0,79	380,0	0,834000
280S	37,00	50,00	740	78,00	6,6	477,50	1,9	2,0	91,5	0,79	496,0	1,930000
280M	45,00	60,00	740	94,00	6,6	580,74	1,9	2,0	92,0	0,79	520,0	3,650000
315S	55,00	75,00	740	111,00	6,6	709,80	1,8	2,0	92,8	0,81	900,0	4,790000
315M	75,00	100,00	740	151,00	6,6	967,91	1,8	2,0	93,0	0,81	1000,0	5,580000
315LA	90,00	125,00	740	178,00	6,6	1161,49	1,8	2,0	93,8	0,82	1060,0	6,370000
315LB	110,00	150,00	740	217,00	6,4	1419,60	1,8	2,0	94,0	0,82	1130,0	7,230000
355MA	132,00	180,00	740	261,00	6,4	1703,50	1,8	2,0	93,7	0,82	1500,0	7,900000
355MB	160,00	220,00	740	313,00	6,4	2064,90	1,8	2,0	94,2	0,82	1600,0	10,300000
355L	200,00	270,00	740	388,00	6,4	2581,10	1,8	2,0	94,5	0,83	1700,0	12,300000



## 2 POLES 3000 rpm

Size	Power		Rpm	In (A)	Is / In	Cn (Nm)	Cs / Cn	Cmax / Cn	Rend. % $\eta$	Cos $\phi$ %	Weight kg	J Kgm <sup>2</sup>
	kW	HP										
<b>Alluminium motors - Volt 230/400/50 Hz</b>												
80A	0,75	1,0	2875	1,68	5,3	2,49	2,5	3,0	77,4	0,83	8,2	0,001200
80B	1,10	1,5	2875	2,37	7,0	3,65	3,2	3,8	79,6	0,84	9,2	0,001400
90S	1,50	2,0	2890	3,16	7,1	4,96	2,7	3,5	81,3	0,84	13,1	0,002900
90L	2,20	3,0	2890	4,48	6,9	4,27	2,4	3,0	83,2	0,85	16,0	0,005500
100L	3,00	4,0	2891	5,86	8,0	9,91	3,2	4,0	84,6	0,87	22,3	0,010900
112M	4,00	5,5	2914	7,64	7,5	13,11	2,5	3,0	85,8	0,88	30,4	0,012600
132SA	5,50	7,5	2937	10,60	7,5	17,90	2,7	3,5	87,0	0,86	46,0	0,037700
132SB	7,50	10,0	2940	13,90	7,5	24,40	24,0	3,3	88,1	0,88	51,2	0,049900

## Cast iron motors - Volt 400/690/50 Hz

160MA	11,00	15,0	2930	19,90	7,6	35,85	2,2	2,9	89,4	0,89	108,0	0,037700
160MB	15,00	20,0	2930	36,90	7,6	48,89	2,3	3,0	90,3	0,89	117,0	0,049900
160L	18,50	25,0	2937	33,00	7,4	60,20	2,3	3,1	90,9	0,89	135,0	0,055000
180M	22,00	30,0	2940	39,50	7,8	71,46	2,8	3,2	91,3	0,88	183,0	0,075000
200LA	30,00	40,0	2950	53,40	7,8	97,12	2,6	3,0	92,0	0,88	227,0	0,124000
200LB	37,00	50,0	2950	64,80	7,7	119,79	2,6	3,0	92,5	0,89	246,0	0,139000
225M	45,00	60,0	2960	78,40	7,5	145,19	2,4	2,6	92,9	0,89	297,0	0,233000
250M	55,00	75,0	2965	94,50	7,1	117,20	2,3	2,8	93,2	0,90	379,0	0,312000
280S	75,00	100,0	2970	128,00	7,4	241,16	2,5	2,8	93,8	0,90	519,0	0,579000
280M	90,00	125,0	2970	152,00	7,6	289,39	2,8	2,8	94,1	0,91	580,0	0,675000
315S	110,00	150,0	2975	185,00	6,9	353,11	2,4	2,8	94,3	0,91	948,0	1,800000
315M	132,00	180,0	2975	221,00	7,1	423,73	2,6	2,9	94,6	0,91	1009,0	1,820000
315LA	160,00	220,0	2975	265,00	7,1	513,61	2,5	2,9	84,8	0,92	1111,0	2,080000
315LB	200,00	270,0	2975	330,00	6,9	642,02	2,5	2,8	95,0	0,92	1142,0	2,380000
355M	250,00	340,0	2980	412,00	7,0	801,17	2,5	2,8	95,0	0,92	1908,0	3,000000
355L	315,00	430,0	2980	520,00	7,0	1009,48	2,5	2,9	95,0	0,92	2346,0	3,500000

## 4 POLES 1500 rpm

## Alluminium motors - Volt 230/400/50 Hz

80B	0,8	1,0	1400	1,78	5,0	5,12	2,4	2,9	79,6	0,76	11,0	0,00210
90S	1,1	1,5	1400	2,53	6,0	7,30	3,0	3,5	81,4	0,77	13,1	0,00230
90L	1,5	2,0	1445	3,39	6,8	9,91	3,2	3,8	82,8	0,77	16,3	0,00270
100LA	2,2	3,0	1440	4,64	7,0	14,60	3,0	3,5	84,3	0,81	23,5	0,00540
100LB	3,0	4,0	1440	6,18	7,0	19,90	2,6	3,3	85,5	0,82	26,0	0,00670
112M	4,0	5,5	1445	8,12	7,5	26,40	3,5	4,0	86,6	0,82	33,1	0,00950
132S	5,5	7,5	1455	10,90	6,4	36,10	2,2	2,8	87,7	0,83	46,1	0,02140
132M	7,5	10,0	1455	14,50	7,0	49,20	2,4	3,0	88,7	0,84	54,3	0,02960

## Cast iron motors - Volt 400/690/50 Hz

160M	11,0	15,0	1460	21,00	6,9	71,90	2,5	2,9	89,8	0,84	110,0	0,07470
160L	15,0	20,0	1460	28,10	7,5	98,10	2,5	3,0	90,6	0,85	132,0	0,09180
180M	18,5	25,0	1420	34,00	7,8	120,20	2,6	3,1	91,2	0,86	172,0	0,13900
180L	22,0	30,0	1420	40,20	7,5	142,90	2,6	3,1	91,6	0,86	180,0	0,15800
200L	30,0	40,0	1470	54,40	7,1	194,90	2,4	2,9	92,3	0,86	247,0	0,26200
225S	37,0	50,0	1480	66,20	7,5	238,80	2,5	2,7	92,7	0,87	297,0	0,40600
225M	45,0	60,0	1480	80,10	7,6	290,40	2,5	2,8	92,6	0,87	322,0	0,46900
250M	55,0	75,0	1480	97,50	7,3	354,90	2,6	2,7	93,5	0,87	413,0	0,66000
280S	75,0	100,0	1480	132,00	7,6	484,00	2,7	2,7	94,0	0,87	558,0	1,12000
280M	90,0	125,0	1480	158,00	7,5	580,70	2,7	2,7	94,2	0,87	632,0	1,46000
315S	110,0	150,0	1485	191,00	7,1	707,40	2,7	2,9	94,5	0,88	826,0	3,11000
315M	132,0	180,0	1485	228,00	7,3	889,00	2,7	2,9	94,7	0,88	1037,0	3,62000
315LA	160,0	220,0	1485	273,00	7,4	1029,00	3,0	3,0	94,9	0,89	1107,0	4,13000
315LB	200,0	270,0	1485	341,00	7,6	1286,00	3,0	3,0	95,1	0,89	1156,0	4,73000
355M	250,0	340,0	1490	421,00	7,5	1602,00	2,8	2,9	95,1	0,90	1734,0	6,50000
355L	315,0	430,0	1490	531,00	7,4	2019,00	2,6	2,8	95,1	0,90	1940,0	8,20000

**6 POLES 1000 rpm**

Size	Power		Rpm	In (A)	Is / In	Cn (Nm)	Cs / Cn	Cmax / Cn	Rend. % $\eta$	Cos $\phi$ %	Weight kg	J Kgm <sup>2</sup>
	kW	HP										
<b>Alluminium motors - Volt 230/400/50 Hz</b>												
90S	0,75	1,0	934	2,0	4,5	7,67	2,2	2,4	75,9	0,72	13,0	0,002900
90L	1,10	1,5	945	2,8	4,5	11,10	2,4	2,6	78,1	0,72	16,5	0,003500
100L	1,50	2,0	945	3,6	4,2	15,20	1,8	2,2	79,8	0,75	23,2	0,006900
112M	2,20	3,0	960	5,1	4,5	21,90	2,3	2,8	81,8	0,76	32,0	0,014000
132S	3,00	4,0	964	6,8	4,5	29,70	1,8	2,4	83,3	0,76	42,0	0,028600
132MA	4,00	5,5	965	9,0	5,0	39,60	2,3	2,7	84,6	0,76	51,0	0,035700
132MB	5,50	7,5	965	12,0	5,5	54,40	1,9	2,8	86,0	0,77	61,0	0,044900
<b>Cast iron motors - Volt 400/690/50 Hz</b>												
160M	7,50	10,0	970	15,9	6,5	73,80	2,0	3,0	87,2	0,78	130,0	0,081000
160L	11,00	15,0	970	22,9	7,5	108,30	2,4	3,3	88,7	0,78	156,0	0,116000
180L	15,00	20,0	975	29,8	6,4	146,90	2,0	2,7	89,7	0,81	183,0	0,207000
200LA	18,50	25,0	980	36,4	7,0	180,30	2,3	3,0	90,4	0,81	220,0	0,315000
200LB	22,00	30,0	980	42,0	7,0	214,40	2,3	2,8	90,9	0,83	240,0	0,360000
225M	30,00	40,0	980	56,2	6,5	292,30	2,2	2,7	91,7	0,84	275,0	0,547000
250M	37,00	50,0	980	67,3	6,9	360,60	2,5	2,7	92,2	0,86	385,0	0,843000
280S	45,00	60,0	980	81,5	7,0	438,50	2,2	2,4	92,7	0,86	482,0	1,390000
280M	55,00	75,0	980	99,2	7,1	536,00	2,4	2,5	93,1	0,86	559,0	1,650000
315S	75,00	100,0	985	134,0	7,3	727,20	2,8	3,0	93,7	0,86	933,0	4,110000
315M	90,00	125,0	985	160,0	7,1	872,60	2,7	2,9	94,0	0,86	1013,0	4,780000
315LA	110,00	150,0	985	196,0	7,4	1066,00	2,9	2,9	94,3	0,86	1086,0	5,450000
315LB	132,00	180,0	985	231,0	7,6	1280,00	3,0	3,1	94,6	0,87	1208,0	6,120000
355MA	160,00	220,0	990	277,0	7,6	1543,00	3,1	3,1	94,8	0,88	1581,0	9,500000
355MB	200,00	270,0	990	345,0	7,8	1929,00	3,0	3,0	95,0	0,88	1632,0	10,400000

## B3 motor dimensions

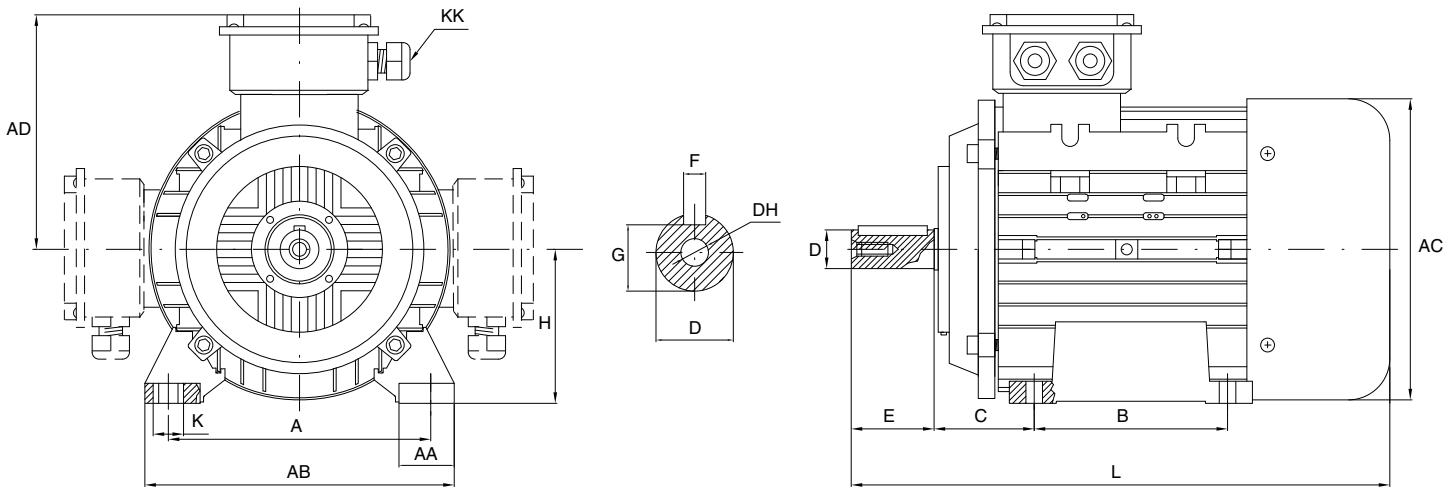

Size	Poles	A	B	C	D	E	F	G	H	K	AB	AC	AD	L	KK	DH
<b>Alluminium motors</b>																
56		90	71	36	9	20	3	7,2	56	5,8	110	120	100	195	1-M16x1,5	M4x12
63		100	80	40	11	23	4	8,5	63	7,0	125	130	100	215	1-M16x1,5	M4x12
71		112	90	45	14	30	5	11,0	71	7,0	140	150	110	246	1-M16x1,5	M5x12
80		125	100	50	19	40	6	15,5	80	10,0	160	170	135	285	1-M20x1,5	M6x16
90S		140	100	56	24	50	8	20,0	90	10,0	178	185	137	335	1-M20x1,5	M8x19
90L		140	125	56	24	50	8	20,0	90	10,0	178	185	137	335	1-M20x1,5	M8x19
100L		160	140	63	28	60	8	24,0	100	12,0	206	206	150	376	2-M20x1,5	M10x22
112M		190	140	70	28	60	8	24,0	112	12,0	222	228	170	400	2-M25x1,5	M10x22
132S		216	140	89	38	80	10	33,0	132	12,0	257	267	190	460	2-M25x1,5	M12x28
132M		216	178	89	38	80	10	33,0	132	12,0	257	267	190	500	2-M25x1,5	M12x28
<b>Cast iron motors</b>																
160M		254	210	108	42	110	12	37,0	160	15,0	320	330	255	615	2-M32x1,5	M16x36
160L		254	254	108	42	110	12	37,0	160	15,0	320	330	255	670	2-M32x1,5	M16x36
180M		279	241	121	48	110	14	42,5	180	15,0	355	380	280	700	2-M32x1,5	M16x36
180L		279	279	121	48	110	14	42,5	180	15,0	355	380	280	740	2-M32x1,5	M16x36
200L		318	305	133	55	110	16	49,0	200	19,0	395	420	305	770	2-M40x1,5	M20x42
225S	2P	356	286	149	-	-	-	-	225	19,0	435	470	335	-	2-M40x1,5	M20x42
	4P-8P	356	286	149	60	140	18	53,0	225	19,0	435	445	335	820	2-M40x1,5	M20x42
225M	2P	356	311	149	55	110	16	49,0	225	19,0	435	445	335	815	2-M40x1,5	M20x42
	4P-8P	356	311	149	60	140	18	53,0	225	19,0	435	470	335	845	2-M40x1,5	M20x42
250M	2P	406	349	168	60	140	18	53,0	250	24,0	490	510	370	910	2-M63x1,5	M20x42
	4P-8P	406	349	168	65	140	18	53,0	250	24,0	490	510	370	910	2-M63x1,5	M20x42
280S	2P	457	368	190	65	140	18	58,0	280	24,0	550	580	410	985	2-M63x1,5	M20x42
	4P-8P	457	368	190	75	140	20	67,5	280	24,0	550	580	410	985	2-M63x1,5	M20x42
280M	2P	457	419	190	65	140	18	58,0	280	24,0	550	580	410	1035	2-M63x1,5	M20x42
	4P-8P	457	419	190	75	140	20	67,5	280	24,0	550	580	410	1035	2-M63x1,5	M20x42
315S	2P	508	406	216	65	140	18	58,0	315	28,0	635	620	630	1185	2-M63x1,5	M20x42
	4P-8P	508	406	216	80	170	22	71,0	315	28,0	635	645	630	1215	2-M63x1,5	M20x42
315M	2P	508	457	216	65	140	18	58,0	315	28,0	635	645	630	1295	2-M63x1,5	M20x42
	4P-8P	508	457	216	80	170	22	71,0	315	28,0	635	645	630	1325	2-M63x1,5	M20x42
315L	2P	508	508	216	65	140	18	58,0	315	28,0	635	645	630	1295	2-M63x1,5	M20x42
	4P-8P	508	508	216	80	170	22	71,0	315	28,0	635	645	630	1325	2-M63x1,5	M20x42
355M	2P	610	560	254	75	140	20	67,5	355	28,0	730	710	655	1500	2PG63x1,5	M20x42
	4P-8P	610	560	254	95	170	25	86,0	355	28,0	730	710	655	1530	2PG63x1,5	M20x42
355L	2P	610	630	254	75	140	20	67,5	355	28,0	730	710	655	1500	2PG63x1,5	M20x42
	4P-8P	610	630	254	95	170	25	86,0	355	28,0	730	710	655	1530	2PG63x1,5	M20x42

## B5 motor dimensions

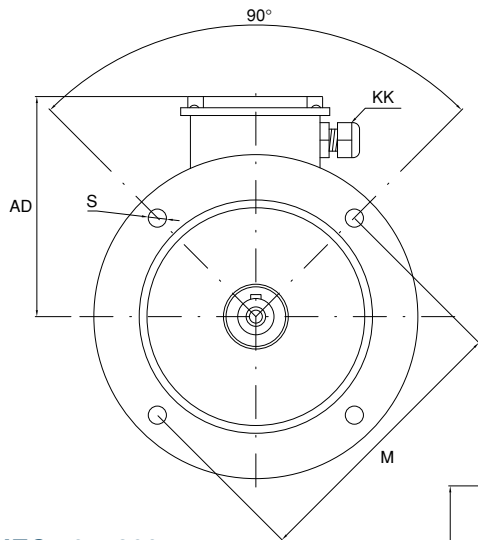

IEC 56 ÷ 200

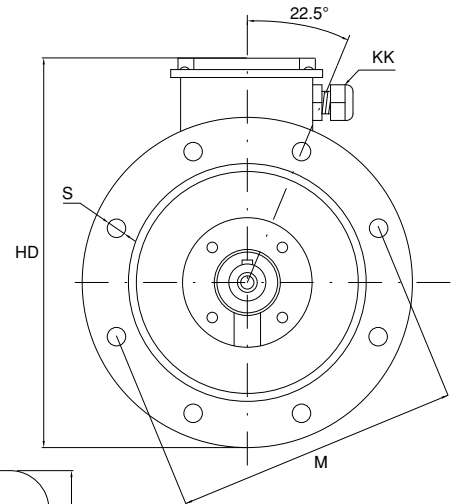

IEC 225 ÷ 355

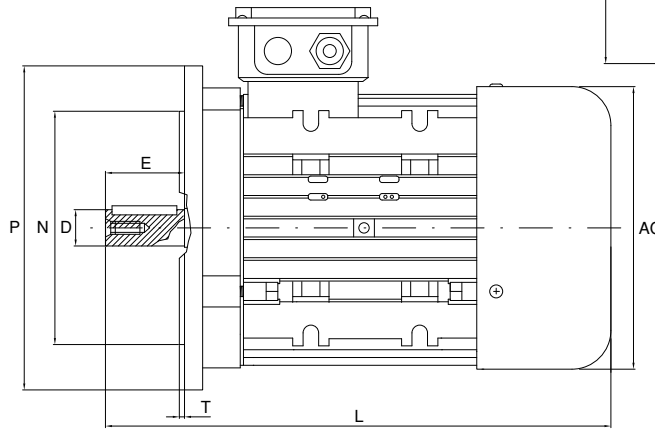
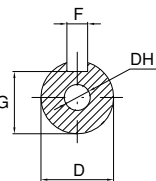

Size	AC	AD	D	DH	E	F	G	KK	L	M	N	P	S	T	
<b>Alluminium motors</b>															
56	120	100	9	M4x12	20	3	7,2	1-M16x1,5	195	65	80	120	7	2,5	
63	130	100	11	M4x12	23	4	8,5	1-M16x1,5	215	115	95	140	10	3,0	
71	150	110	14	M5x12	30	5	11,0	1-M16x1,5	246	130	110	160	10	3,5	
80	160	135	19	M6x16	40	6	15,5	1-M20x1,5	285	165	130	200	12	3,5	
90S	185	137	24	M8x19	50	8	20,0	1-M20x1,5	335	165	130	200	12	3,5	
90L	185	137	24	M8x19	50	8	20,0	1-M20x1,5	335	165	130	200	12	3,5	
100L	206	150	28	M10x22	60	8	24,0	2-M20x1,5	376	215	180	250	15	4,0	
112M	228	170	28	M10x22	60	8	24,0	2-M25x1,5	400	215	180	250	15	4,0	
132S	267	190	38	M12x28	80	10	33,0	2-M25x1,5	460	265	230	300	15	4,0	
132M	267	190	38	M12x28	80	10	33,0	2-M25x1,5	500	265	230	300	15	4,0	

<b>Cast iron motors</b>																
Size	Poles	D	E	F	G	M	N	P	S	T	fori flangia	AC	HD	L	DH	KK
160M		42	110	12	37,0	300	250	350	19	5	4	330	420	615	M16x36	2-M32x1,5
160L		42	110	12	37,0	300	250	350	19	5	4	315	420	670	M16x36	2-M32x1,5
180M		48	110	14	42,5	300	250	350	19	5	4	380	455	700	M16x36	2-M32x1,5
180L		48	110	14	42,5	300	250	350	19	5	4	355	455	740	M16x36	2-M32x1,5
200L		55	110	16	49,0	350	300	400	19	5	4	420	505	770	M20x42	2-M40x1,5
225S	2P	-	-	-	-	400	350	450	19	5	8	470	560	-	M20x42	2-M40x1,5
	4P-8P	60	140	18	53,0	400	350	450	19	5	8	470	560	820	M20x42	2-M40x1,5
225M	2P	55	110	16	49,0	400	350	450	19	5	8	470	560	815	M20x42	2-M40x1,5
	4P-8P	60	140	18	53,0	400	350	450	19	5	8	470	560	845	M20x42	2-M40x1,5
250M	2P	60	140	18	53,0	500	450	550	19	5	8	510	615	910	M20x42	2-M63x1,5
	4P-8P	65	140	18	58,0	500	450	550	19	5	8	510	615	910	M20x42	2-M63x1,5
280S	2P	65	140	18	58,0	500	450	550	19	5	8	580	680	985	M20x42	2-M63x1,5
	4P-8P	75	140	20	67,5	500	450	550	19	5	8	580	680	985	M20x42	2-M63x1,5
280M	2P	65	140	18	58,0	500	450	550	19	5	8	580	680	1035	M20x42	2-M63x1,5
	4P-8P	75	140	20	67,5	500	450	550	19	5	8	580	680	1035	M20x42	2-M63x1,5
315S	2P	65	140	18	58,0	600	550	660	24	6	8	645	845	1185	M20x42	2-M63x1,5
	4P-8P	80	170	22	71,0	600	550	660	24	6	8	645	845	1215	M20x42	2-M63x1,5
315M	2P	65	140	18	58,0	600	550	660	24	6	8	645	845	1295	M20x42	2-M63x1,5
	4P-8P	80	170	22	71,0	600	550	660	24	6	8	645	845	1325	M20x42	2-M63x1,5
315L	2P	65	140	18	58,0	600	550	660	24	6	8	645	845	1295	M20x42	2-M63x1,5
	4P-8P	80	170	22	71,0	600	550	660	24	6	8	645	845	1325	M20x42	2-M63x1,5
355M	2P	75	140	20	67,5	740	680	800	24	6	8	710	1010	1500	M20x42	2-PG63x1,5
	4P-8P	95	170	25	86,0	740	680	800	24	6	8	710	1010	1530	M20x42	2-PG63x1,5
355L	2P	75	140	20	67,5	740	680	800	24	6	8	710	1010	1500	M20x42	2-PG63x1,5
	4P-8P	95	170	25	86,0	740	680	800	24	6	8	710	1010	1530	M20x42	2-PG63x1,5

## B14 motor dimensions

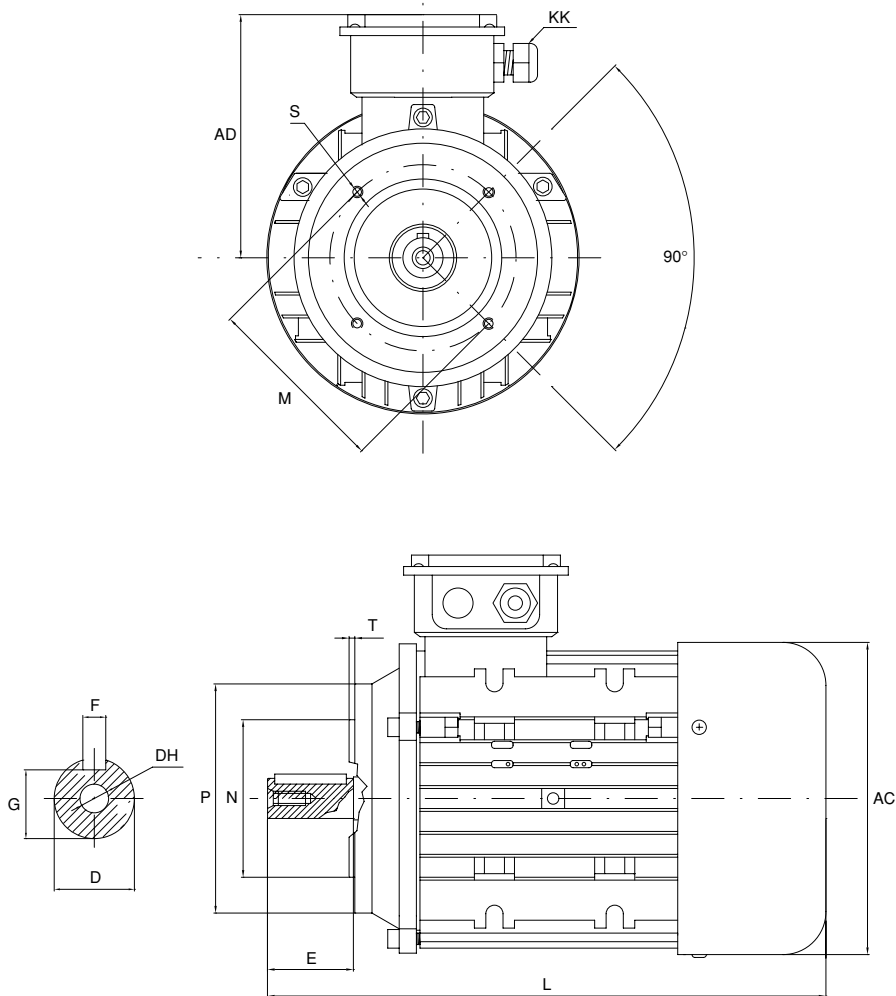

Size	AC	AD	D	DH	E	F	G	KK	L	M	N	P	S	T
<b>Alluminium motors</b>														
56	120	100	9	M4x12	20	3	7,2	1-M16x1,5	195	65	50	80	7	3,0
63	130	100	11	M4x12	23	4	8,5	1-M16x1,5	215	75	60	90	10	3,0
71	150	110	14	M5x12	30	5	11,0	1-M16x1,5	246	85	70	105	10	3,5
80	170	135	19	M6x16	40	6	15,5	1-M20x1,5	285	100	80	120	12	3,5
90S	185	137	24	M8x19	50	8	20,0	1-M20x1,5	335	115	95	140	12	3,5
90L	185	137	24	M8x19	50	8	20,0	1-M20x1,5	335	115	95	140	12	3,5
100L	206	150	28	M10x22	60	8	24,0	2-M20x1,5	376	130	110	160	15	4,0
112M	228	170	28	M10x22	60	8	24,0	2-M25x1,5	400	130	110	160	15	4,0
132S	267	190	38	M12x28	80	10	33,0	2-M25x1,5	460	165	130	200	15	4,0
132M	267	190	38	M12x28	80	10	33,0	2-M25x1,5	500	165	130	200	15	4,0

## Installation, use and maintenance technical manual for CE and/or UL and/or CSA electric asynchronous motors.

Neri Motori declares that the electrical material quoted in this technical manual complies with the following EU Directives:

- L.V.D. 2006/95/EC (Low voltage);
- EMC 2004/108/EC (Electromagnetic compatibility);
- ROHS 2002/95/EC (Dangerous substances);
- M.D. 2006/42/EC (Machine directive) and modifications – Annex IIB, **THE MOTOR MUST NOT RUN BEFORE BEING ASSEMBLED in a CE MACHINE.**

The material complies with the main European Standards:

- EN - 55014 Standards (1994) EMC;
- CEI EN 60034-1 - Rating and performance (2000);
- CEI EN 60034-5 - IP Rating. Degree of body motor protection;
- CEI EN 60204 -1 - Safety of machinery.

### ! WARNING

- 0) Before operating the electrical material read this manual which has been provided with the electric motors (from this point on the term electric motor will be used instead of L.V. electrical material) and the instructions stated therein. The instructions are to be fully and duly complied with before skilled personnel and qualified technicians start up the electric motor. Bear in mind that this manual does not exempt anyone from applying all those technical standards envisaged in the specific sector of electric motors or those general standards associated with the safety of persons, animals or property set forth by the EU.

### ELECTRIC MOTOR INSTALLATION

- 1) The electric motor must be run according to the features stated in the NAME PLATE and ONLY to THESE and must be installed and maintenance carried out according to EUROPEAN STANDARDS.
- 2) The electric motor is not suitable for use near substances that will set on fire without oxygen.
- 3) Before starting up the electric motor, check its overall condition, the shaft, the fan cover, and the wear and tear of the mechanical parts. Also check that the motor shaft turns freely, that the gasket and cable inlet have been mounted correctly and TIGHTENED. Check that all the electrical terminals are wired in the terminal strip and the motor plate values correspond to the network which will power it.

### ! DANGER

**If parts of the motor are damaged and/or the values reported on the motor's rating plate do not EXACTLY match those of the mains that will power it, or the ENVIRONMENTAL CONDITIONS ARE DIFFERENT, do not start the electric motor.**

- 4) Fix the motor into its seat using suitable fastening equipment (**B14 flange attention to screw length and closure, risk of damage for the electrical winding**) and AVOID using the electric motor's eyebolt if it is connected to other machine parts.
- 5) Handling the motor; if it is very heavy, over 30kg or it cannot be perfectly handled because it is not placed on a safe support, use machine tools or similar in order to prevent physical injury, conforming to EU directives.
- 6) Do not start the electric motor if the key is fixed on the motor shaft as this could cause the key to be expelled owing to centrifugal force, see risk factors associated with EN 60204-1.
- 7) Before performing any type of maintenance operations to the electric motor itself or in the vicinity of it, visually check that it has been disconnected from the mains power supply and make sure that it is impossible for the motor to restart unexpectedly and that other masses which have been connected to the motor shaft cannot pull the motor; in accordance to EN 60204-1.
- 8) **WAIT UNTIL THE MOTOR IS AT ROOM TEMPERATURE BEFORE OPENING THE PROTECTION to avoid EXPLOSIONS DUE TO THE TEMPERATURE OR ELECTRICAL CHARGE.**

- 9) It is forbidden to use the motor in environmental conditions which differ from the IP ratings specified on the plate, as per EN 60054-5.
- 10) Connect the motor's frame to earth using the appropriate equipotential terminal identified by the symbol as per EN 60204-1.
- 11) If the electric motor is to be stored, the temperature of the room should be from 0°C to +55°C. After it has been stored for 12 months, check the insulation resistance which should be approximately 1Mohm with continuous test voltage of 500V for  $V_n < 500V$ . Should any differences in the value be noticed this might be due to the presence of humidity in the windings which should be dried; the test should then be repeated.
- 12) Make sure that the mechanical protection of the motor's moving parts or parts connected to it, for instance the pulley belt units, are sufficient as far as safety for personnel, animals or property are concerned, as per EN 60204-1.
- 13) Check that the alignment between motor shaft and rotating parts keyed to the motor is correct or that they are statically and dynamically balanced in order to prevent undesired moments, as per EN 60204-1.
- 14) The shaft of the electric motor has been designed and finished conforming to IEC 72-1 and is to be operated without any shear stress. Shield flange frames and mechanical parts conform to IEC 72-1 standards as far as mechanics are concerned, apart from instances when specific Client requirements have been adhered to.
- 15) Make sure that the electric motor is not a source of noise pressure levels  $L_pA > 80dBA$  as set forth by EU directives. In such cases the unit must be silenced or workers must protect themselves with individual acoustic protective equipment.
- 16) Make sure that the hot parts of the electric motor are adequately protected against touching by personnel, animals or property and **THE GASKET AND CABLE INLET ARE CLOSED CORRECTLY.**
- 17) All risk situations must be adequately indicated with visual signs such as for instance voltage excessive noise or temperature.

### ELECTROMECHANICAL SAFETY OF THE ELECTRIC MOTOR (EN 60204-1)

- 18) Envisage a safety device against overload for power supplied  $> 500W$  in thermal service S1. This can be achieved with a thermal relay and a contactor. It is advisable to fit a thermal safety device in scarcely ventilated places such as the inside of chain guards.
- 19) If required by particular operating conditions of the electric motor in synchronism with other machines, envisage the application of a minimum voltage relay and contactor as per EN 60204-1.
- 20) Variable speed applications are not allowed unless expressly agreed upon at the time the order is being prepared with the manufacturer or as indicated on the motor plate, and must not, however, differ from the rated rotating speed as per EN 60204-1.
- 21) If the speed range is agreed upon with the manufacturer thus increasing the risk factor involved a suitable safety device should be used as per EN 60204-1.
- 22) A safety device must be envisaged against electric motor over currents by means of magnetic relay and contactor or fuses as per EN 60204-1.
- 23) The sizing of the electric motor power supply cables and the admissible voltage % drop must conform to EN 60204-1.
- 24) Cables are to be thermally sized considering the through power ( $I^2 \Delta t = K^2 S^2$ ) as per EN 60204-1.
- 25) When  $I_g [A]$  fault current is known at the expected fault point K and S (cable section  $mm^2$ ) calculate the maximum tripping time  $\Delta T$  (seconds) of magnetic circuit breakers.
- 26) Personnel, animals and property must be protected against indirect contact to parts that are not usually subjected to electric potential but that might be subjected to it in the case of malfunction. Therefore fit a differential relay and contactor with  $I_d < 30mA$  as per EN 60204-1.
- 27) If the turning direction of the motor shaft has been set to one only such direction, this must be clearly indicated with an arrow as per EN60204-1.
- 28) In the event that the motor brakes electrically by means of the inversion of two power supply wires, the motor must not be restarted in the opposite direction as per EN 60204-1.

- 29) **Rearming a safety device is strictly prohibited.** This may be done only and exclusively by the manual intervention of personnel who are skilled in rearming operations as per EN 60204-1.
- 30) **SELF BRAKE MOTOR, follow the technical information on the name plate motor IP = 2 digit + A=ac or D=DC + brake supply = 3 digit + Nm + brake manufacturer (1 digit).**
- 31) **DO NOT USE LUBRICATION ON THE SELF BRAKE MOTOR. Use only compressed air to clean if wet or dusty.**
- 32) **SELF BRAKE MOTOR, after a period of braking, if the braking is not right or if too long, check according to numbers 30) and 31) then if not solved, please contact Neri Motori srl for further information.**

#### DANGER – MANDATORY MAINTENANCE

- 33) The electric motor must be run < 1000msl in an area with a range of temperature (-15°C / +40°C) REFRIDGERATED AIR therefore NEVER GO OVER THIS LIMIT if it is not stated on the name plate of the motor (0°C/+40C° if Pn<600W).
- 34) Make sure that the assembly of the electric motors allows for correct air intake, circulation and its frame is devoid of encrustation or dust which would worsen the heat exchange with the air coolant as per EN60204-1 which would entail faulty over heating risk, **TO CLEAN ONLY COMPRESSED AIR MUST BE USED.**
- 35) The components of the motor are in weight approximately 5% inorganic – iron 55% - copper 30% - aluminium 10% - and are to be disposed of conforming to EEC directives.

#### ELECTRICAL CONNECTION

##### 36) 6 PIN TERMINAL BOARD

Motor Size mm	Terminal Board Size mm	Pin Size mm	Torque of PIN mm
50	40 x 25	M4 x 12	2
56/63/71	44 x 27	M4 x 12	2
80	50 x 32	M4 x 15	2
90	50 x 32	M4 x 15	2
100	56 x 36	M5 x 15	3
112	56 x 36	M5x 15	3
132	70 x 45	M6 x 20	4
160	95 x 60	M8 x 24	5
180	95 x 60	M8 x 24	5
200	95 x 60	M8 x 24	5

##### 37) 8 PIN TERMINAL BOARD

Motor Size mm	Terminal Board Size mm	Pin Size mm	Torque of PIN mm
56	50 x 43	M4 x 12	2
63	50 x 43	M4 x 12	2
71	50 x 43	M4 x 12	2
80	50 x 43	M4 x 12	2
90	50 x 43	M4 x12	2
100	50 x 43	M4 x 12	2
112	50 x 43	M4 x 12	2

##### 38) CABLE PRESS SIZE

Motor Size mm	Size Cable Press mm	Holes for Cable inlet mm
50	M16 x 1,5	5 - 10
56	M16 x 1,5	5 - 10
63	M16 x 1,5	5 - 10
71	M16 x 1,5	5 - 10
80	M20 x 1,5	7 - 13
90	M20 x 1,5	7 - 13
100	M20 x 1,5	7 - 13
112	M20 x 1,5	7 - 13
132	M32 x 1,5	13 - 18
160	M32 x 1,5	13 - 18
180	M32 x 1,5	13 - 18
200	M32 x 1,5	13 - 18

##### 39) ELECTRICAL SUPPLY

###### Motor Series T / AT (see marking on terminal board motor)

- STAR CONNECTION right rotation DE side = (W2+U2+V2) and supply to (U1/V1/W1) with RST line;
- DELTA CONNECTION right rotation DE side = (W2+U1) / (U2+V1) / (V2+W1) and supply to (U1/V1/W1) with RST line;
- SEPARATE SUPPLY BRAKE / PTC / HEATER = supply to P1/P2.
- Blower 3ph IC416 = Supply as per motors Series T / AT;
- ENCODER = Refer to dwg ENCODER CONNECTION inside electrical connection box motor.
- Accessories = Refer to dwg INSIDE ELECTRICAL CONNECTION BOX MOTOR.

- 40) **IF IN DOUBT PLEASE CONTACT NERI MOTORI SRL, see the General Catalogue or website [www.nerimotori.com](http://www.nerimotori.com), any other operation not indicated involves the immediate termination of any warranty**

Date 12 February 2013



## General conditions of sale

For sale condition please consult our web site [www.nerimotori.com](http://www.nerimotori.com)

#### Reservation of right to modification.

This publication annuls and replaces every previous edition or revision. We reserve the right to make modifications without notice.

All data contained in this catalogue are purely indicative and not binding for our company.

## Certified quality

Neri Motori is a well known leading manufacturer of asynchronous electric motors. We operate according to the highest quality Standards.

Our primary goal is to achieve the best performance for all our products and to meet our customers' requirements.

This is confirmed by the certificates obtained over the years, confirming a continuous commitment in providing high technology solutions thanks to the company's extensive know-how.



**CE Marks**



**Quality system certification according to UNI EN ISO 9001 (2000)**



**ATEX - 94/9/CE approval**







