



## 590+ DRV

Frame 1, 2, 3, 4, 5, 6 & 7

HA470388U003 Issue 4  
Product Manual

aerospace  
climate control  
**electromechanical**  
filtration  
fluid & gas handling  
hydraulics  
pneumatics  
process control  
sealing & shielding



ENGINEERING YOUR SUCCESS.



# Integrator Series 2

## DC590+ DRV DC Digital Drive

**HA470388U003**    **ISSUE 4**

Compatible with Version 8.x Software onwards

2012 Parker Hannifin Manufacturing Ltd.

All rights strictly reserved. No part of this document may be stored in a retrieval system, or transmitted in any form or by any means to persons not employed by a Parker Hannifin Manufacturing Limited company without written permission from Parker Hannifin Manufacturing Limited. Although every effort has been taken to ensure the accuracy of this document it may be necessary, without notice, to make amendments or correct omissions. Parker Hannifin Manufacturing Limited cannot accept responsibility for damage, injury, or expenses resulting therefrom.

### WARRANTY

Refer to Parker Hannifin Manufacturing Limited Terms and Conditions of Sale. These documents are available on request at [www.parker.com](http://www.parker.com).

Parker Hannifin Manufacturing Limited reserves the right to change the content and product specifications without notice.



**PRODUCT MANUAL**

# Safety Information



**FAILURE OR IMPROPER SELECTION OR IMPROPER USE OF THE PRODUCTS DESCRIBED HEREIN OR RELATED ITEMS CAN CAUSE DEATH, PERSONAL INJURY AND PROPERTY DAMAGE.**

- This document and other information from Parker-Hannifin Corporation, its subsidiaries and authorized distributors provide product or system options for further investigation by users having technical expertise.
- The user, through its own analysis and testing, is solely responsible for making the final selection of the system and components and assuring that all performance, endurance, maintenance, safety and warning requirements of the application are met. The user must analyze all aspects of the application, follow applicable industry standards, and follow the information concerning the product in the current product catalog and in any other materials provided from Parker or its subsidiaries or authorized distributors.
- To the extent that Parker or its subsidiaries or authorized distributors provide component or system options based upon data or specifications provided by the user, the user is responsible for determining that such data and specifications are suitable and sufficient for all applications and reasonably foreseeable uses of the components or systems.



# Safety Information



## Requirements

**IMPORTANT** Please read this information **BEFORE** installing the equipment.

### Intended Users

This manual is to be made available to all persons who are required to install, configure or service equipment described herein, or any other associated operation.

The information given is intended to highlight safety issues, and to enable the user to obtain maximum benefit from the equipment.

Complete the following table for future reference detailing how the unit is to be installed and used.

INSTALLATION DETAILS			
<b>Model Number</b> <i>(see product label)</i>		<b>Where installed</b> <i>(for your own information)</i>	
<b>Unit used as a:</b> <i>(refer to "Certification")</i>	<input type="radio"/> Component <input type="radio"/> Relevant Apparatus	<b>Unit fitted:</b>	<input checked="" type="checkbox"/> Enclosure

### Application Area

The equipment described is intended for industrial (non-consumer) motor speed control utilising DC motors.




### Personnel

Installation, operation and maintenance of the equipment should be carried out by qualified personnel. A qualified person is someone who is technically competent and familiar with all safety information and established safety practices; with the installation process, operation and maintenance of this equipment; and with all the hazards involved.



# Safety Information

## Product Warnings

 <p><b>Caution</b> Risk of electric shock</p>	 <p><b>Caution</b> Refer to documentation</p>	 <p><b>Earth/Ground</b> Protective Conductor Terminal</p>
--	--	--

## Hazards

### **DANGER! - Ignoring the following may result in injury**

1. This equipment can endanger life by exposure to rotating machinery and high voltages.
2. The equipment must be permanently earthed due to the high earth leakage current, and the drive motor must be connected to an appropriate safety earth.
3. Ensure all incoming supplies are isolated before working on the equipment. Be aware that there may be more than one supply connection to the drive.
4. There may still be dangerous voltages present at power terminals (motor output, supply input phases, DC bus and the brake, where fitted) when the motor is at standstill or is stopped.
5. For measurements use only a meter to IEC 61010 (CAT III or higher). Always begin using the highest range. CAT I and CAT II meters must not be used on this product.
6. Allow at least 10 minutes for the drive's capacitors to discharge to safe voltage levels (<50V). Use the specified meter capable of measuring up to 1000V dc & ac rms to confirm that less than 50V is present between all power terminals and between power terminals and earth.
7. Unless otherwise stated, this product must NOT be dismantled. In the event of a fault the drive must be returned. Refer to "Routine Maintenance and Repair".

# Safety Information



## **WARNING! - Ignoring the following may result in injury or damage to equipment**

### **SAFETY**

Where there is conflict between EMC and Safety requirements, personnel safety shall always take precedence.

- Never perform high voltage resistance checks on the wiring without first disconnecting the drive from the circuit being tested.
- Whilst ensuring ventilation is sufficient, provide guarding and /or additional safety systems to prevent injury or damage to equipment.
- When replacing a drive in an application and before returning to use, it is essential that all user defined parameters for the product's operation are correctly installed.
- All control and signal terminals are SELV, i.e. protected by double insulation. Ensure all external wiring is rated for the highest system voltage.
- Thermal sensors contained within the motor must have at least basic insulation.
- All exposed metalwork in the Drive is protected by basic insulation and bonded to a safety earth.
- RCDs are not recommended for use with this product but, where their use is mandatory, only Type B RCDs should be used.

### **EMC**

- In a domestic environment this product may cause radio interference in which case supplementary mitigation measures may be required.
- This is a product of the restricted sales distribution class according to IEC 61800-3.
- This equipment contains electrostatic discharge (ESD) sensitive parts. Observe static control precautions when handling, installing and servicing this product.
- It is designated as “professional equipment” as defined in EN61000-3-2. Permission of the supply authority shall be obtained before connection to the low voltage supply.

# Safety Information



## CAUTION!

### APPLICATION RISK

- The specifications, processes and circuitry described herein are for guidance only and may need to be adapted to the user's specific application. We can not guarantee the suitability of the equipment described in this Manual for individual applications.
- It is advised that motors with significantly lower voltage ratings than the supply voltage are **NOT** used with the drive.

---

### RISK ASSESSMENT

Under fault conditions, power loss or unintended operating conditions, the drive may not operate as intended. In particular:

- Stored energy might not discharge to safe levels as quickly as suggested, and can still be present even though the drive appears to be switched off
- The motor's direction of rotation might not be controlled
- The motor speed might not be controlled
- The motor might be energised

A drive is a component within a drive system that may influence its operation or effects under a fault condition. Consideration must be given to:

- Stored energy
  - Supply disconnects
  - Sequencing logic
  - Unintended operation
-

# Contents

## DC590+ DRV DC DIGITAL DRIVE

Hazards.....	4
--------------	---

### CHAPTER 1 GETTING STARTED

About this Manual .....	1-1
How the Manual is Organised .....	1-1
Initial Steps .....	1-1
Equipment Inspection and Storage .....	1-2
Packaging and Lifting Details .....	1-2

### CHAPTER 2 PRODUCT OVERVIEW

How it Works .....	2-1
Control Features.....	2-2
Understanding the Product Code .....	2-3
Catalog Number ( North America) .....	2-3
Model Number (Europe) .....	2-4
Model Number (Europe - Legacy Numbers) .....	2-5
Product Range.....	2-8
Product Identification .....	2-9
Component Identification .....	2-10
Keypads.....	2-16
Option Boards .....	2-16

### CHAPTER 3 INSTALLING THE DRIVE

Mechanical Installation .....	3-1
Design Recommendations .....	3-1
Mounting Instructions.....	3-2
Product Dimensions .....	3-3
Ventilation and Cooling Requirements .....	3-3
Line Reactor/Isolation Transformer .....	3-4
Electrical Installation .....	3-5
EMC Wiring Details .....	3-6
Wiring Instructions - Minimum Connections .....	3-10
Additional Control Connections .....	3-18
Motor Field Connections .....	3-19
DC Contactor - External Va Sensing .....	3-23
Power Board Circuit Descriptions .....	3-26

Optional Equipment .....	3-42
Remote Mounting the Keypad .....	3-42
Dynamic Braking Option .....	3-44
Blower Motor Protector Option .....	3-44
Control Transformer Option (factory-fitted) .....	3-44
Speed Feedback Options .....	3-45
Communications Technology Options .....	3-50
Frame 6: Assembly and Installation .....	3-51
Assembly .....	3-53
Electrical Installation .....	3-61
Frame 7: Additional Information.....	3-62
Installation Drawings .....	3-64
Connection Diagrams.....	3-77

### CHAPTER 4 CALIBRATION AND START-UP

Introduction .....	4-1
Initial Checks .....	4-1
Check Motor .....	4-2
Check Supply .....	4-2
Calibrate the Drive .....	4-3
Initial Drive Start.....	4-5
Tune the Current Loop (AUTOTUNE) .....	4-8
Set Up Field Control .....	4-10
Set Up Speed Feedback .....	4-12
Setup For Field Weakening .....	4-14
Adjust Speed Loop .....	4-15
Other Important Parameters .....	4-16
Recording Parameters .....	4-16
Starting and Stopping Methods.....	4-17
Stopping Methods .....	4-17
Normal Starting Method .....	4-23
Advanced Starting Methods .....	4-24
External Control of the Drive .....	4-26

### CHAPTER 5 CONTROL LOOPS

Control Loops - Principle of Operation.....	5-1
Current Loop .....	5-1
Speed Loop .....	5-4

Field Control	5-5
<b>CHAPTER 6 THE KEYPAD</b>	
Connecting the 6911 Keypad	6-1
Control Key Definitions	6-2
Indications	6-3
The Menu System	6-5
The Local Menu	6-6
Navigating the Menu System	6-7
Changing a Parameter Value	6-7
The Menu System Map	6-8
The Keypad Menus	6-10
Menu Shortcuts and Special Key Combinations	6-21
How to Save, Restore and Copy your Settings	6-23
Saving Your Application	6-23
Restoring Saved Settings	6-24
Copying an Application	6-24
<b>CHAPTER 7 TRIPS AND FAULT FINDING</b>	
Trips and Fault Finding	7-1
Trips	7-1
Fault Finding	7-2
Using the Keypad to Manage Trips	7-14
Hardware Troubleshooting	7-23
Common Performance Problems	7-29
Test Points	7-30
<b>CHAPTER 8 ROUTINE MAINTENANCE AND REPAIR</b>	
Maintenance	8-1
Repair	8-2
Saving Your Application Data	8-2
Returning the Unit to Parker SSD Drives	8-2
Disposal	8-3
Technical Support Checks	8-3
Repairs for Frames 4 & 5	8-5
Repairs for Frame 6	8-6
Repairs for Frame 7	8-11
<b>APPENDIX A SERIAL COMMUNICATIONS</b>	
System Port (P3)	A-1
UDP Support	A-2
DSELite Support	A-5

5703 Support	A-6
EI Bisynch ASCII Support	A-9
EI Binary Support	A-14
Error Codes	A-29
<b>APPENDIX B CERTIFICATION</b>	
Introduction	B-1
Europe	B-1
What are the European Directives?	B-1
CE Marking for the Low Voltage Directive (LVD) 2006/95/EC	B-2
CE Marking for the EMC Directive 2004/108/EC	B-2
United States of America & Canada	B-4
Compliance	B-4
Conditions for Compliance with UL508c	B-4
Australia & New Zealand	B-10
EMC Standards	B-10
EMC	B-11
Emissions Limits	B-11
EMC General Installation Considerations	B-13
Certificates	B-15
<b>APPENDIX C PARAMETER SPECIFICATION TABLES</b>	
Parameter Tables	C-1
Specification Table: Tag Number Order	C-2
Parameter Table: MMI Menu Order	C-36
<b>APPENDIX D PROGRAMMING</b>	
Programming Your Application	D-1
Programming with Block Diagrams	D-1
Function Block Descriptions	D-11
The Default Application	D-148
Block Diagrams	D-148
<b>APPENDIX E TECHNICAL SPECIFICATIONS</b>	
Technical Specifications	E-1



# Chapter 1 **Getting Started**

A few things you should do when you first receive the unit.

- About this Manual
  - How the Manual is Organised
  - Initial Steps
- Equipment Inspection and Storage
- Packaging and Lifting Details





# About this Manual

This manual is intended for use by the installer, user and programmer of the DC590+ DRV DC Digital Drive. It assumes a reasonable level of understanding in these three disciplines.

**NOTE** Please read all Safety Information before proceeding with the installation and operation of this unit.

Enter the "Model No" from the rating label into the "Installation Details" table at the front of this manual. It is important that you pass this manual on to any new user of this unit.

This manual is for the following models from the DC590+ DRV DC Digital Drive:

- Three phase, regenerative, four quadrant armature controllers:
  - 590 - for currents up to 720A
  - 598 - external stack option for currents exceeding 720A
- Three phase non-regenerative, two quadrant armature controllers:
  - 591 - for currents up to 720A
  - 599 - external stack option for currents exceeding 720A
- 590H and 591H (further detail is provided in the separate Addendum manual)

---

## How the Manual is Organised

This Engineering Reference manual is organised into chapters and appendices, indicated by the numbering on the edge of each page.

The manual is more detailed than the QuickStart manual, and so is of use to the unfamiliar as well as the high-end user.

### Application Block Diagram

You will find this at the rear of Appendix D: "Programming". These will become your programming tool as you become more familiar with the software.

---

## Initial Steps

Use the manual to help you plan the following:

### *Installation*

Know your requirements:

- certification requirements, CE/UL/c-UL conformance
- conformance with local installation requirements
- supply and cabling requirements

## 1-2 Getting Started

### ***Operation***

Know your operator:

- how is it to be operated, local and/or remote?
- what level of user is going to operate the unit?
- decide on the best menu level for the Keypad (where supplied)

### ***Programming (Keypad or suitable PC programming tool only)***

Know your application:

- plan your “block diagram programming”
- enter a password to guard against illicit or accidental changes
- learn how to back-up your application data
- customise the Keypad to the application

## Equipment Inspection and Storage

- Check for signs of transit damage
- Check the product code on the rating label conforms to your requirement.

If the unit is not being installed immediately, store the unit in a well-ventilated place away from high temperatures, humidity, dust, or metal particles.

Refer to Chapter 2: “Product Overview” to check the rating label/product code.

Refer to Chapter 8: “Routine Maintenance and Repair” for information on returning damaged goods.

Refer to Appendix E: “Technical Specifications” - Environmental Details for the storage temperature.

## Packaging and Lifting Details

### **WARNING**

**The packaging is combustible. Igniting it may lead to the generation of lethal toxic fumes.**

- ◆ Save the packaging in case of return. Improper packaging can result in transit damage.
- ◆ Use a safe and suitable lifting procedure when moving the unit. Never lift the unit by its terminal connections.

Prepare a clear, flat surface to receive the drive before attempting to move it. Do not damage any terminal connections when putting the unit down.

## Chapter 2 **Product Overview**

An introduction to the DC590+ DRV range of products, and a quick look at the Keypad and available plug-in Options.

How it Works

Control Features

Understanding the Product Code

- Catalog Number ( North America)
- Model Number (Europe)
- Model Number (Europe - Legacy Numbers)

Product Range

Product Identification

Component Identification

Keypads

Option Boards



# How it Works

**NOTE** Refer to Chapter 5: “Control Loops” for a more detailed explanation.

In *very* simple terms, the drive controls the dc motor with the use of *Control Loops* - an inner Current Loop and an outer Speed Loop. These control loops can be seen in the Application Block Diagram. The block diagram shows all the drive's software connections.

Using the Keypad, you can select the control loops to be used by the drive to provide either:

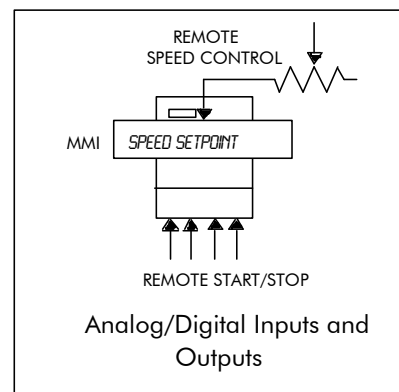
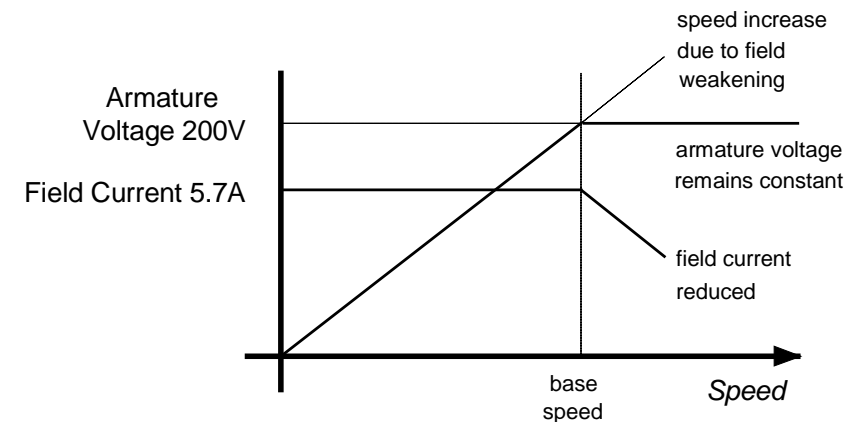
- Current Control
- Speed Control (default)

It is usual to supply a Current or Speed Feedback signal to the appropriate loop for more effective control of the drive. Current Feedback sensors are built-in, whereas Speed Feedback is provided directly from the armature sensing circuit (default), or by tachogenerator, encoder or Microtach connection to the relevant option board.

When in Speed Control, you can modify the performance of the drive further by controlling the motor field, i.e. Field Control. By weakening the field current, you can obtain an increase in motor speed beyond that normally achievable for the rated Armature Voltage of the dc motor.

The Drive is controlled remotely using digital/analog inputs and outputs. It cannot be directly *stopped* or *started* using the keypad.

By plugging in a COMMS Option Board, the Drive can be linked into a network and controlled by a PLC/SCADA or other intelligent device.



# Control Features

<b>Control</b>	Control Circuits	Fully isolated from power circuit (SELV)
	Output Control	<ul style="list-style-type: none"> <li>Fully controlled 3-phase thyristor bridge</li> <li>Microprocessor implemented phase control extended firing range</li> <li>For use on 50 or 60Hz supplies with a frequency compliance range of 45 to 65Hz</li> <li>Phase control circuits are phase rotation insensitive</li> </ul>
	Control Action	<ul style="list-style-type: none"> <li>Fully digital</li> <li>Advanced PI with fully adaptive current loops for optimum dynamic performance</li> <li>Self Tuning Current Loop utilising "Autotune" algorithm</li> <li>Adjustable speed PI with integral defeat</li> </ul>
	Speed Control	<ul style="list-style-type: none"> <li>By Armature Voltage feedback with IR compensation</li> <li>By Encoder feedback or analog tachogenerator</li> </ul>
	Speed Range	100 to 1 typical with tachogenerator feedback
	Steady State Accuracy	<ul style="list-style-type: none"> <li>0.01 % Encoder Feedback with Digital setpoint (serial link or P3)</li> <li>0.1 % Analog Tach Feedback</li> <li>2 % Voltage Feedback</li> </ul> <p><b>NOTE</b> Long term analog accuracy is subject to tachogenerator temperature stability.</p>
	Adjustments	All adjustments in software can be altered by the Keypad or via serial communications. The Keypad provides monitoring and adjustment of parameters and levels, in addition to diagnostic facilities.
<b>Protection</b>		<ul style="list-style-type: none"> <li>High energy MOVs</li> <li>Overcurrent (instantaneous)</li> <li>Overcurrent (inverse time)</li> <li>Field failure</li> <li>Speed feedback failure</li> <li>Motor overtemperature</li> </ul>
		<ul style="list-style-type: none"> <li>Thyristor Stack overtemperature (Force ventilated units)</li> <li>Thyristor "Trigger" failure</li> <li>Thyristor Snubber Network</li> <li>Zero-speed detection</li> <li>Standstill logic</li> <li>Stall protection</li> </ul>
<b>Diagnostics</b>		<ul style="list-style-type: none"> <li>Fully computerised with first fault latch and automatic display</li> <li>Digital LCD monitoring</li> <li>Full diagnostic information available on RS422/RS485</li> <li>LED circuit state indication</li> </ul>

**Table 2-1 Control Features**

# Understanding the Product Code

## Catalog Number ( North America)

The unit is fully identified using an alphanumeric code which records how the drive was calibrated and its various settings when despatched from the factory. The Product Code appears as the “Cat No”. Each block of the Product Code is identified as below:

Catalog Number (North America)																																												
Block No.	Variable	Description																																										
1	XXXX	Generic product 955+ : Base model number DRV																																										
2	X	1 digit identifying the nominal 3 phase ac power supply voltage; 1 = 110-115 Vac                      C = 575 Vac 8 = 220-500 Vac                      D = 600 Vac																																										
3	X	1 digit identifying the control type: R = Regenerative, 4Q DC Drive N = Non-regenerative, 2Q DC Drive																																										
4	XXXX	Four characters specifying the output in Horsepower:  <i>Equivalent European Rating</i> <table style="width: 100%; border-collapse: collapse;"> <tr> <td style="width: 33%;">0007 = 7.5 * (Frame 1)</td> <td style="width: 33%; text-align: center;">15A</td> <td style="width: 33%;">0125 = 125 (Frame 3)</td> </tr> <tr> <td>0020 = 20 * (Frame 1)</td> <td style="text-align: center;">35A</td> <td>0150 = 150 (Frame 3)</td> </tr> <tr> <td>0030 = 30 * (Frame 2)</td> <td style="text-align: center;">55A</td> <td>0200 = 200 (Frame 4)</td> </tr> <tr> <td>0040 = 40 * (Frame 2)</td> <td style="text-align: center;">70A</td> <td>0250 = 250 (Frame 4)</td> </tr> <tr> <td>0050 = 50 * (Frame 2)</td> <td style="text-align: center;">90A</td> <td>0300 = 300 (Frame 4)</td> </tr> <tr> <td>0060 = 60 * (Frame 2)</td> <td style="text-align: center;">110A</td> <td>0400 = 400 (Frame 4)</td> </tr> <tr> <td>0075 = 75 * (Frame 2)</td> <td style="text-align: center;">125A</td> <td>0500 = 500 (Frame 4)</td> </tr> <tr> <td>0100 = 100 * (Frame 2)</td> <td style="text-align: center;">165A</td> <td>0600 = 600 (Frame 5)</td> </tr> <tr> <td></td> <td></td> <td>0700 = 700 (Frame 5)</td> </tr> <tr> <td></td> <td></td> <td>0800 = 800 (Frame 5)</td> </tr> <tr> <td></td> <td></td> <td>0900 = 900 (Frame 7)</td> </tr> <tr> <td></td> <td></td> <td>1000 = 1000 (Frame 7)</td> </tr> <tr> <td></td> <td></td> <td>1250 = 1250 (Frame 7)</td> </tr> <tr> <td></td> <td></td> <td>1500 = 1500 (Frame 7)</td> </tr> </table>	0007 = 7.5 * (Frame 1)	15A	0125 = 125 (Frame 3)	0020 = 20 * (Frame 1)	35A	0150 = 150 (Frame 3)	0030 = 30 * (Frame 2)	55A	0200 = 200 (Frame 4)	0040 = 40 * (Frame 2)	70A	0250 = 250 (Frame 4)	0050 = 50 * (Frame 2)	90A	0300 = 300 (Frame 4)	0060 = 60 * (Frame 2)	110A	0400 = 400 (Frame 4)	0075 = 75 * (Frame 2)	125A	0500 = 500 (Frame 4)	0100 = 100 * (Frame 2)	165A	0600 = 600 (Frame 5)			0700 = 700 (Frame 5)			0800 = 800 (Frame 5)			0900 = 900 (Frame 7)			1000 = 1000 (Frame 7)			1250 = 1250 (Frame 7)			1500 = 1500 (Frame 7)
0007 = 7.5 * (Frame 1)	15A	0125 = 125 (Frame 3)																																										
0020 = 20 * (Frame 1)	35A	0150 = 150 (Frame 3)																																										
0030 = 30 * (Frame 2)	55A	0200 = 200 (Frame 4)																																										
0040 = 40 * (Frame 2)	70A	0250 = 250 (Frame 4)																																										
0050 = 50 * (Frame 2)	90A	0300 = 300 (Frame 4)																																										
0060 = 60 * (Frame 2)	110A	0400 = 400 (Frame 4)																																										
0075 = 75 * (Frame 2)	125A	0500 = 500 (Frame 4)																																										
0100 = 100 * (Frame 2)	165A	0600 = 600 (Frame 5)																																										
		0700 = 700 (Frame 5)																																										
		0800 = 800 (Frame 5)																																										
		0900 = 900 (Frame 7)																																										
		1000 = 1000 (Frame 7)																																										
		1250 = 1250 (Frame 7)																																										
		1500 = 1500 (Frame 7)																																										
5	XXX	Up to three characters specifying the build options (factory installed): CX = Control transformer fitted (* units only) 240 = 240V AC Contactor fitted (* units only)																																										



## Model Number (Europe)

The unit is fully identified using an alphanumeric code which records how the drive was calibrated, its various settings when despatched from the factory, and the country of origin.

The Product Code appears as the “Model No”. Each block of the Product Code is identified as shown:

		Block 1				Block 2		Block 3		Block 4								
		Example ▶ 955R				53	2150	1	1	P	00	U	0	A	0	00		
Product Family	DC590+ DRV Series DC Digital Drive - regen	955R																
	DC590+ DRV Series DC Digital Drive - non-regen	955N																
	Supply Voltage	kW	Output Current (A)	HP	Frame Size													
Current / Power Ratings	500v 3ph					53												
		7	15	7.5	1		2150	1										
		15	35	20	1		2350	1										
		18	40	25	2		2400	2										
		22	55	30	2		2550	2										
		30	70	40	2		2700	2										
		37	90	50	2		2900	2										
		45	110	60	2		3110	2										
		55	125	75	2		3125	2										
		75	165	100	2		3165	2										
Auxiliary Supply	115V 1ph										1							
	230V 1ph										2							
Mechanical Style	Panel Mounting (Frames 1 & 2)																	
Special Options	None																	
	Documented special options (01-99) (Refer to local sales office)																	
Language	English (50/60Hz)																	
	German																	
	Spanish																	
	French																	
	Italian																	
Keypad	None																	
	6901 keypad fitted																	
Speed Feedback	Analog Tacho																	
	Glass Fiberoptic encoder																	
	Plastic Fiberoptic encoder																	
	Armature Voltage																	
	Wire-ended Encoder																	
Communications	None																	
	ControlNet																	
	DeviceNet																	
	Ethernet																	
	Link																	
	ModBus +																	
	CanOpen																	
	Profibus																	
	RS485/RS422																	
Blower Overload	No Blower Overload																	
	0.10 - 0.16A																	
	0.16 - 0.25A																	
	0.25 - 0.4A																	
	0.4 - 0.63A																	
	0.63 - 1.0A																	
	1.0 - 1.6A																	
	1.6 - 2.5A																	
	2.5 - 4.0A																	
	4.0 - 6.3A																	

## Model Number (Europe - Legacy Numbers)

Model Number (Europe)		
Block No.	Variable	Description
1	XXXXXXXX	Generic product 590P-DRV : 590+DRV 4Q DC Drive 591P-DRV : 590+DRV 2Q DC Drive
2	XXXX	Four digits identifying the maximum dc output current rating that may be calibrated for each size of product:  0015 = 15A (Frame 1) 0035 = 35A (Frame 1)  0040 = 40A (Frame 2) 0055 = 55A (Frame 2) 0070 = 70A (Frame 2) 0090 = 90A (Frame 2) 0110 = 110A (Frame 2) 0125 = 125A (Frame 2) 0165 = 165A (Frame 2)
3	XXX	3 digits identifying the nominal 3 phase ac power, supply voltage:  220 110 to 220V ( $\pm 10\%$ ) 50/60Hz 500 220 to 500V ( $\pm 10\%$ ) 50/60Hz 600 500 to 600V ( $\pm 10\%$ ) 50/60Hz (Frame 4 & 5 only) 690 500 to 690V ( $\pm 10\%$ ) 50/60Hz (Frame 7 only)
4	XXXX	4 digits describing the mechanical package including livery and mechanical package style:  <i>First two digits (on the left)</i> <i>Livery</i> 00      Standard Parker SSD Livery 05      Distributor Livery 01-04 and 06-99      Defined customer liveries TBA  <i>Third digit</i> <i>Mechanical Package Style</i> 1      Standard (IP20), protected panel mounting 4      Panel Mounting IP20 plus Roof Vent Kit      (Frame 4 only)  <i>Fourth digit</i> <i>Keypad</i> 0      No Keypad 1      Built-in 6901 Keypad

Model Number (Europe)		
Block No.	Variable	Description
5	XX	Two characters specifying the user interface language: UK = English                      SP = Spanish * FR = French                        IT = Italian * GR = German *                      * refer to Customer Services
6	XXX	Up to three characters specifying the feedback option (one must be fitted): ARM = Armature Voltage        ENP = Encoder (plastic fibre-optic) AN = Analog Tacho                ENG = Encoder (glass fibre-optic) ENW = Encoder (wire-ended)
7	XXXXX	Up to five characters specifying the protocol for the 6055 communications Tech Box option: 0 = No Comms option fitted EI00 = RS485 (EI BINARY, EI ACSII or MODBUS RTU) PROF = PROFIBUS DP LINK = LINK DNET = DEVICENET CAN = CANOPEN MBP = MODBUS+ ENET = ETHERNET
8	XXX	Up to three characters specifying the auxiliary mains power supply for contactor (all units): 110 = 110(±10%) 50/60Hz 230 = 220V to 240V (±10%) 50/60Hz CX = Control transformer fitted internally
9	XXX	Motor blower output: 0 = Not fitted                      063 = 0.40 to 0.63A                      400 = 2.50 to 4.00A 016 = 0.10 to 0.16A                100 = 0.63 to 1.00A                      630 = 4.0A to 6.30A 025 = 0.16 to 0.25A                160 = 1.00 to 1.60A 040 = 0.25 to 0.40A                250 = 1.60 to 2.50A
10	XXX	Auxiliary volt-free contact: AUX = Fitted
11	XXX	Up to three characters specifying engineering special options: 0 = No special option

## Door Assembly Product Code

The door assembly is identified separately. The Product Code appears on a label displayed under the terminal cover.

Block No.	Variable	Description
1	XXXXX	Generic product 590PD : Fits Frame 4 and 5 units 590PXD : Fits Frame 3 and H units
2	XXXX	4 digits describing the mechanical package including livery and mechanical package style: <i>First two digits (on the left)</i> <i>Livery</i> 00    Standard Parker SSD Livery 05    Distributor Livery 01-04 and 06-99                          Defined customer liveries TBA <i>Third digit</i> <i>Mechanical Package Style</i> 1    Standard <i>Fourth digit</i> <i>Keypad</i> 0    No Keypad 1    Built-in Keypad
3	XX	Two characters specifying the user interface language: UK = English FR = French GR = German (refer to Customer Services) SP = Spanish (refer to Customer Services) IT = Italian (refer to Customer Services)
4	XXX	Up to three characters specifying engineering special options: 0 = No special option

# Product Range

The DC590+ DRV contains the DC590+ controller, a contactor and ac supply fusing. An optional control transformer, motor blower and dynamic brake are also available.

## *System Design*

The drive is designed for use in a suitable enclosure, with associated control equipment. The unit accepts a variety of standard three-phase ac supply voltages depending upon the model, and is suitable for the powering of DC shunt field and permanent magnet motors, providing controlled dc output voltage and current for armature and field.

All units are designed for simple and economical panel mounting. Plug-in control connectors simplify the fitting and removal of the unit to the panel.

Where possible, standard parts are used throughout the range thereby reducing the variety of spare parts required to maintain a multi-drive system. For example, the same basic control boards are used in all controllers regardless of horsepower or bridge configuration.

The control circuit is totally isolated from the power circuit thus simplifying the interconnection of controllers within a system and improving operator safety. The coding circuitry adjusts automatically to accept supply frequencies between 45-65Hz and possesses high immunity to supply-borne interference. The controllers are phase rotation insensitive.

## *Control and Communications*

The drive is controlled by a 32-bit microcontroller providing advanced features such as:

- **Complex control algorithms** which are not achievable by simple analog techniques.
- **Software-configurable control circuitry** built around standard software blocks.
- **Serial link communications** with other drives or a PC for advanced process systems.

The Keypad gives access to parameters, diagnostic messages, trip settings and full application programming.

## *Regenerative and Non-Regenerative Models*

The DC590+ DRV Series includes both regenerative and non-regenerative models:

- **Regenerative drives** consist of two fully-controlled thyristor bridges, contactors, fuses, and a field bridge with full transient and overload protection, together with sophisticated electronic control of acceleration and deceleration, speed and torque in both directions of rotation.
- **Non-regenerative drives** consist of one fully-controlled thyristor bridge, contactors, fuses, and a field bridge with full transient and overload protection, together with its associated electronic control circuitry, and provide accurate speed and/or torque control in one selected direction of rotation.

## *Field Regulator*

A field regulator is standard. The regulator consists of a full-wave, half-controlled, single phase thyristor bridge with transient and overload protection. It provides either a fixed voltage or fixed current source, depending upon the selected mode of operation. The field current mode of operation can be further enhanced to provide field weakening for controlling motors in extended speed or constant horsepower control.

# Product Identification

■ Indicates a panel-mounted DRV

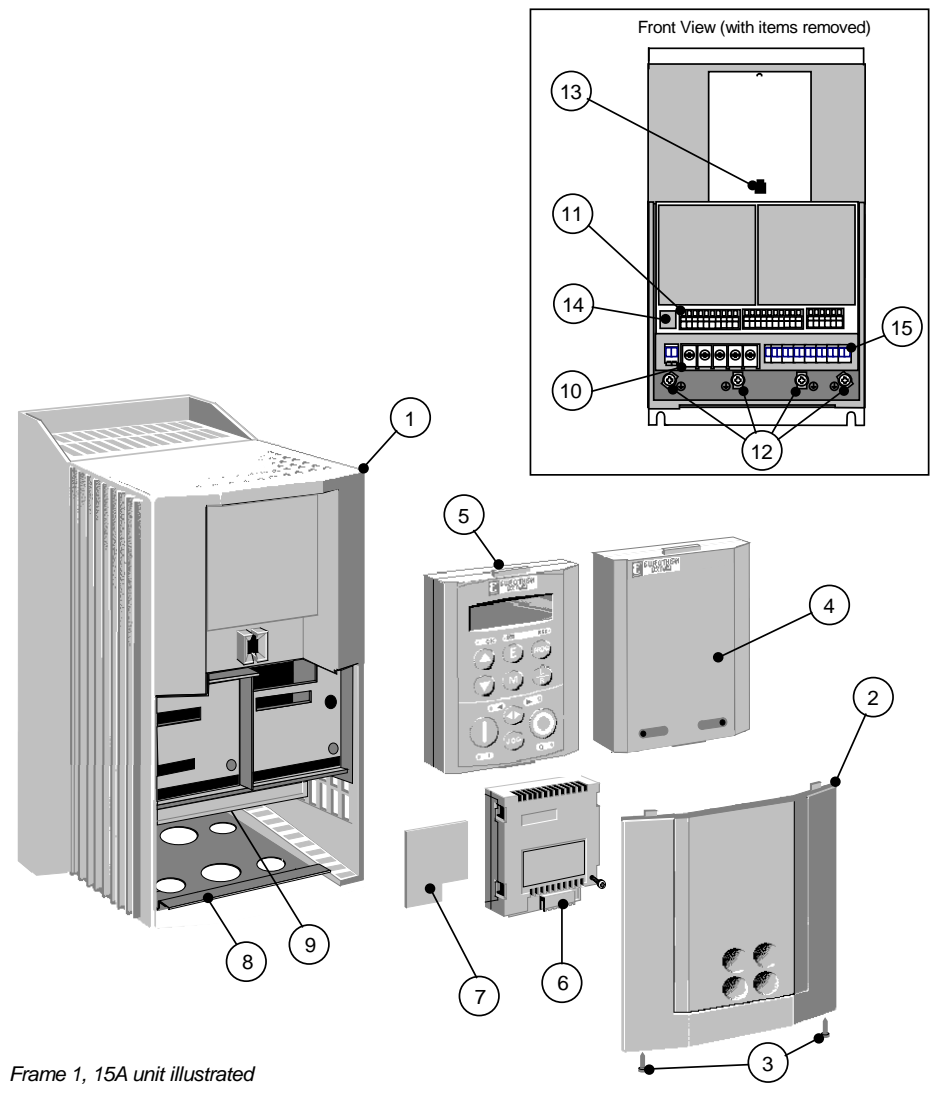
**Output Currents (armature):**

Frame 1	Frame 2	Frame 3	Frame 4	Frame 5	Frame 6	Frame H
15A	40A (Europe only)	206A	360A	1000A	1250A	1050A
35A	55A	246A	425A	1200A	1660A	1450A
	70A		490A	1334A	1950A	1600A
	90A		700A			2000A
	110A		815A			2400A
	125A					
	165A					

# Component Identification

## DC590+ DRV DC Digital Drive (Frames 1 & 2)

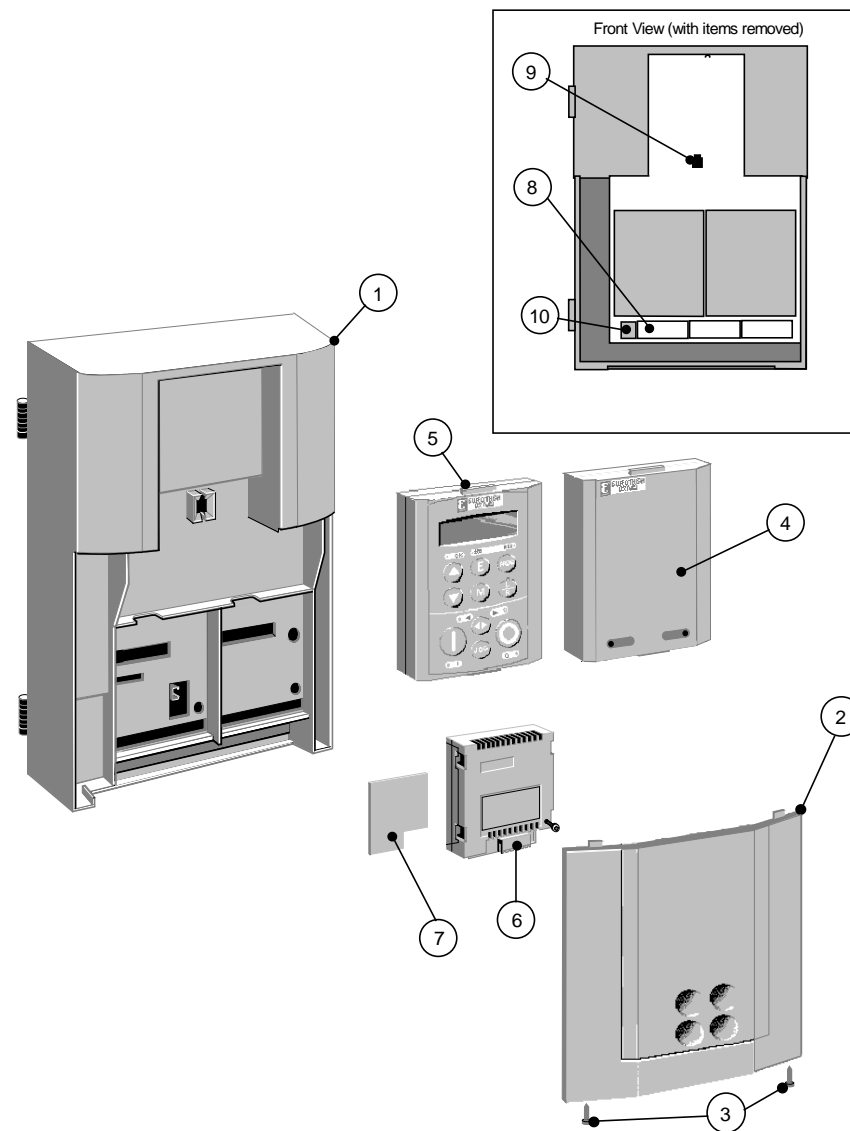
1	Main drive assembly
2	Terminal cover
3	Terminal cover retaining screw
4	Blank cover (part number: LA389836U001)
5	6901 Keypad
6	COMMS technology box (optional)
7	Speed feedback technology card (optional)
8	Gland plate
9	Power terminal shield
10	Power terminals
11	Control terminals
12	Earthing/grounding points
13	Keypad port
14	RS232 programming port
15	Auxiliary power, external contactor, blower and isolated thermistor terminals



Frame 1, 15A unit illustrated

## 590+ Door Assembly (Frames 3, 4, 5 & 7)

1	Main door assembly
2	Terminal cover
3	Terminal cover retaining screw
4	Blank cover (part number: LA389836U001)
5	6901 Keypad
6	COMMS technology box (optional)
7	Speed feedback technology card (optional)
8	Control terminals
9	Keypad port
10	RS232 programming port (P3)

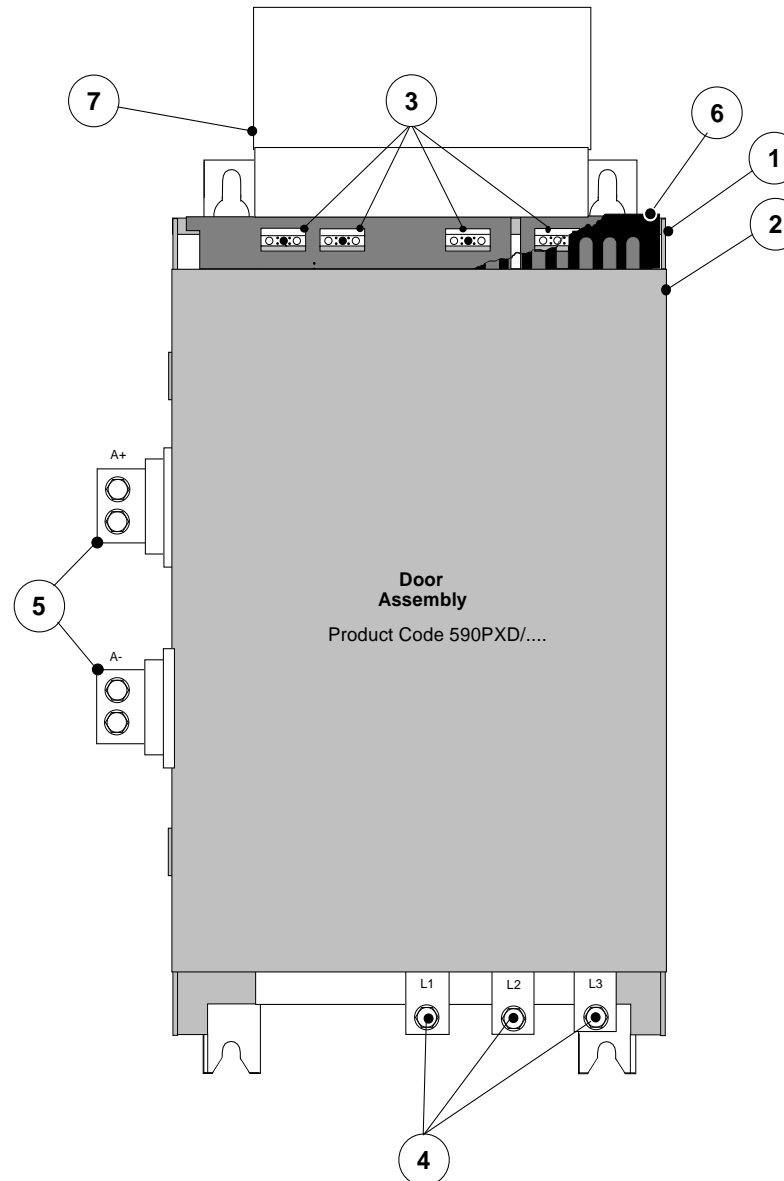


Frames 4 & 5 : Product Code 590PD/... (illustrated)  
 Frames 3 & H : Product Code 590PXD/... (with additional motor thermistor terminals)



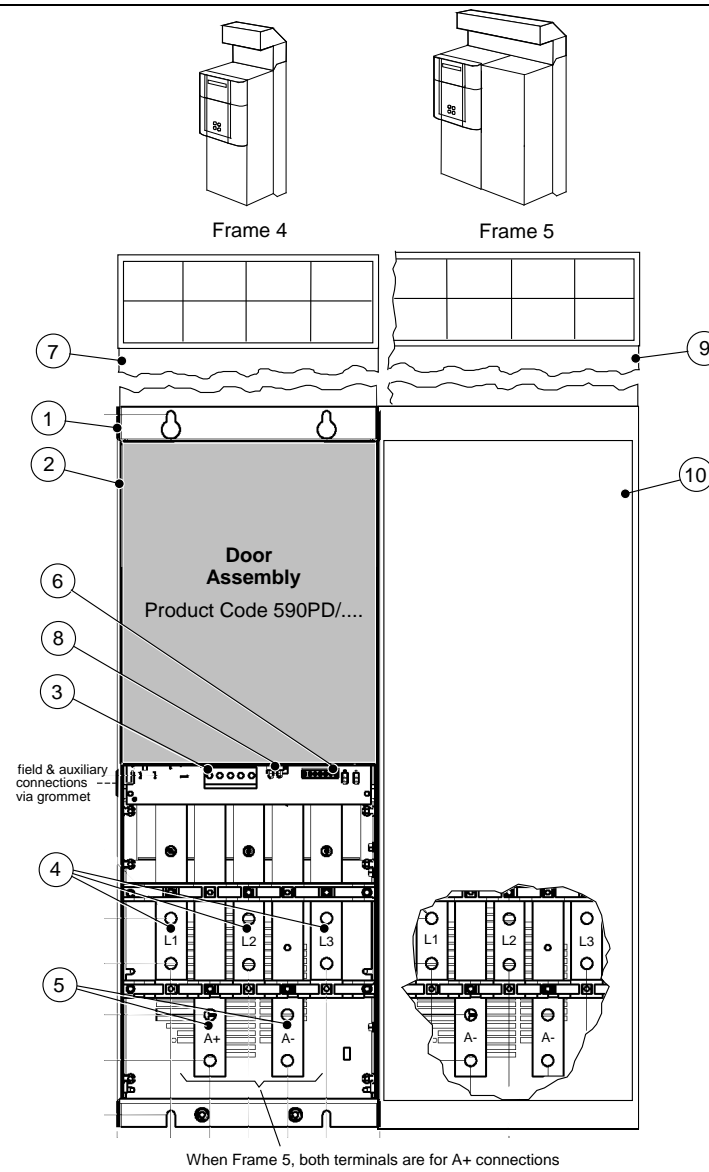
## DC590+ Drive (Frame 3)

1	Main drive assembly
2	Door assembly
3	Field wiring terminals
4	Busbars - main power input
5	Busbars - main power output
6	IP20 Top Cover
7	IP20 Fan Housing (where fitted)



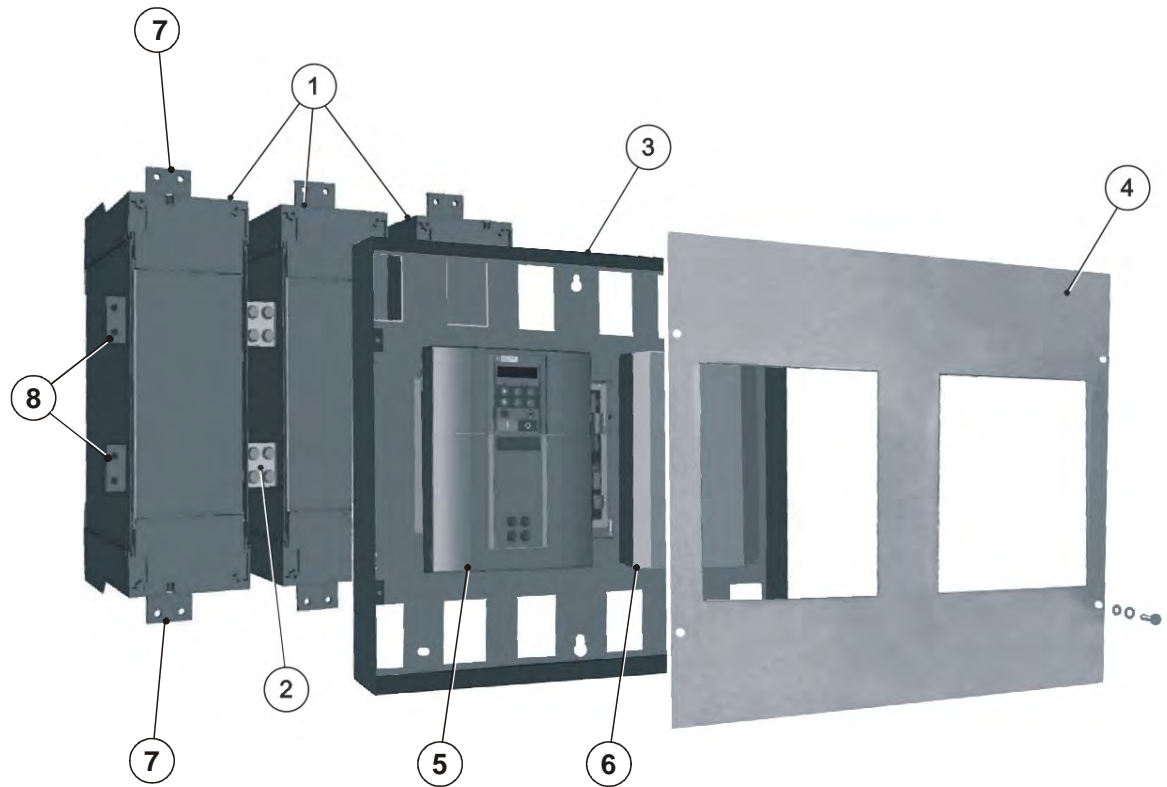
## DC590+ Drive (Frames 4 & 5)

1	Main drive assembly
2	Standard door assembly
3	Motor field terminals
4	Busbars - main power input
5	Busbars - main power output
6	Auxiliary supply, contactor and motor thermistor terminals
7	Frame 4 External vent (where fitted)
8	Contactor Control Select
9	Frame 5 External vent (where fitted)
10	Terminal Cover (Frame 5)

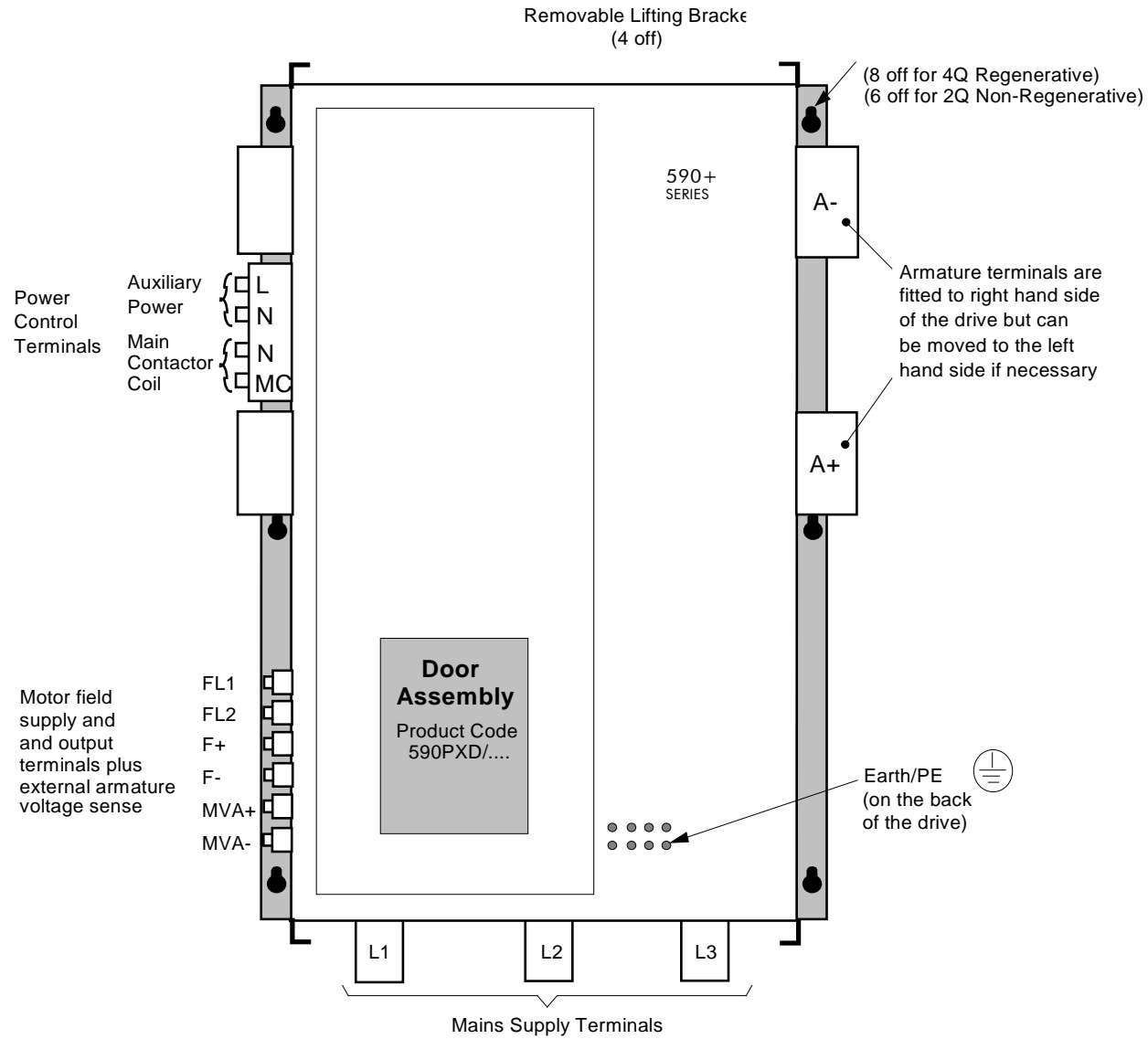


## 590+ Drive (Frame 6)

1	Phase assemblies - L1, L2, L3
2	Fishplate
3	Control Panel Assembly
4	Front Cover
5	Standard Door Assembly
6	Field Controller
7	Busbars - main power input
8	Busbars - main power output



# DC590+ Product (Frame 7)



Refer to Appendix E: Technical Specification "DC590+ DRV Frame 7" for additional information.

## Keypads

The drive is fitted with the 6901 Keypad.

It provides Local control of the drive, monitoring and complete access for application programming.

For example, you can start and stop the motor, check on diagnostic information, and change parameters values on the drive.

The keypad fits to the front of the drive, however, you can also remote-mount the keypad up to 3 metres away.

Alternatively, you can fit a 6911 keypad. The 6911 provides a larger screen and improved functionality.

For remote-mounting, you'll need the correct Remote Mounting Kit. Refer to Chapter 6: "The Keypad".



6901 Keypad



6911 Keypad

## Option Boards

A range of Option Boards are available for the 590 drive. The boards provide for Speed Feedback and Communications.

Refer to Chapter 3 : "Installing the Drive" - Speed Feedback and Technology Options.

## Chapter 3 **Installing the Drive**

This chapter describes the mechanical and electrical installation of the drive and associated equipment.

### Mechanical Installation

- Design Recommendations

### Mounting Instructions

- Product Dimensions
- Ventilation and Cooling Requirements
- Line Reactor/Isolation Transformer

### Electrical Installation

- EMC Wiring Details
- Wiring Instructions - Minimum Connections
- Additional Control Connections
- Motor Field Connections
- DC Contactor - External Va Sensing
- Power Board Circuit Descriptions

### Optional Equipment

- Remote Mounting the Keypad
- Dynamic Braking Option
- Blower Motor Protector Option
- Control Transformer Option (factory-fitted)
- Speed Feedback Options
- Communications Technology Options

### Frame 6: Assembly and Installation

- Assembly
- Electrical Installation

### Frame 7: Additional Information

#### Installation Drawings

#### Connection Diagrams



# Mechanical Installation

**IMPORTANT** Refer to "Installation Drawings", page 3-51 for further information.

The DC590+ DRV Digital drive is designed to be relatively simple to install. You should review these procedures *before* beginning them. If you do not understand the instructions or are unsure of your ability to perform the procedures, contact Parker SSD Product Support.

---

## Design Recommendations

The DC590+ DRV is only part of a motor control system. Other parts may include an isolation transformer, branch circuit protection, line reactor and motor. If properly selected and installed, you can assure your process of trouble-free operation.

**NOTE** Read Appendix B : "Certification" for details meeting UL, cUL, and CE certification The chapter contains specific requirements concerning wiring practices and auxiliary equipment.

### Isolation Transformer

DC drives require 3% reactance for proper operation. An isolation transformer can supply this. Select a DELTA-WYE style transformer with a grounded neutral conductor. If the transformer supplies other equipment, verify that the load is balanced on all legs and is rated for the total load.

### Line Reactor

When several drives are connected to an isolation transformer, Parker SSD Drives recommends adding a line reactor for each drive. This prevents SCR line notching from affecting other drives and control equipment.

### Branch Circuit Protection

You must provide branch circuit protection to protect the three-phase supply cabling. Circuit breakers or fuses are often used for this purpose. When choosing the device, the AC current for the drive is  $0.83 \times$  DC Armature Current. Local electrical codes may require an additional safety margin.

### Control Supply

The 120 VAC control supply for the drive is often used to power other control equipment. Make sure that the drive supply is properly filtered to avoid unexpected faults caused by the control supply. Filtering is often accomplished using RC snubbers across AC contactor coils and blocking diodes across DC contactor coils.

### Motor Thermistors

Parker SSD Drives recommends choosing motors with temperature sensitive resistors or switches in the field and interpole windings. These inexpensive devices, often called thermistors or thermostats, protect against motor over-temperature failures. Connect them in series between terminals TH1 and TH2 on the drive.

Thermistors must have a combined working resistance of 750 Ohms or less, rising to 4000 ohms at over-temperature. They are classified by IEC34-II as Mark A.



# Mounting Instructions

The DC590+ DRV Digital drive is designed to mount directly onto a vertical, flat surface. All models are designed with the incoming three-phase supply connections the motor connections at the bottom. Units rated 125 through 500 HP have terminals for the motor field connections and optional motor blower connections mounted on the left. Keep the terminal locations in mind when mounting the drive to accommodate proper wire routing.

## Recommended Tools

Installing a DC590+DRV DC Digital Drive requires a few standard hand tools. A socket wrench to fit either ¼-20 or M6 (as applicable) bolts and nuts is needed to mount the drive to the panel. Screwdrivers and a wire-crimping tool are needed to make various electrical connections. For installing DRVs larger than 165A, wrenches are needed to make some of the electrical connections.

Below is a list of some of the required tools.

Socket wrench with a 6 inch extension

Deep sockets: M10, M13, M17, 7/16", 1/2"

Screwdrivers: Phillips #2, flat blade - 0.5 x 3.0mm, 0.6 x 3.5mm, 0.8 x 4.0mm

Small wire cutters

**NOTE** Holes for the mounting bolts or screws must be placed accurately.

**IMPORTANT** *When drilling mounting holes, cover any components already mounted to the panel to protect them from stray metal filings.*

## Mounting the Units

Insert the mounting studs from the back side of the panel. Attach lock washers and nuts part way onto the lower mounting studs. They will help keep the drive in place when mounting.

### WARNING

**The DC590+ DRV units are heavy. Use proper lifting techniques when moving.**

Lower the bottom slots of the DC590+ DRV Digital drive onto the studs, making sure the slots are between the washers and the panel. Once the drive is resting on the bottom studs, lean it back onto the top two studs. Attach lock washers and nuts on the top studs and finger tighten. Finger tighten the lower studs as well to hold the drive in place. Finally, use the socket wrench to tighten all four nuts securely.

Visually check the drive and its housing for packing material, mounting debris, or any other material that could damage and/or restrict the operation of the equipment.

## Product Dimensions

Refer to “Installation Drawings”, page 3-51 for further information.

## Ventilation and Cooling Requirements

The drive must be able to dissipate the heat it generates during use. Therefore, mount the unit vertically so that a free flow of cool air can pass through the drive. For 7.5 through 60 HP rated models, allow a minimum of 4"(100mm) of clear space above and below the drive to ensure adequate free air flow. Leave 6"(150mm) clearance above and below models rated 75 through 100 HP.

When mounting drives one above the other, allow at least 7"(175mm) between the top and bottom drives. Each drive requires the same clearance as required when used singly. When mounting drives next to each other, leave 1½"(38mm) left to right between units.

Make sure the unit is not mounted on or next to equipment that will cause the drive to overheat. Normal maximum ambient operating temperature is 113°F (45°C) up to 150 HP and 104°F (40°C) for larger drives. Above this limit, the controller must be derated. The maximum ambient operating temperature is 131°F (55°C).

The table below lists the heat dissipation in Watts of DC590+ DRV Digital drives through 500 horsepower (at 500 VDC).

Motor Rating HP @ 500V	Motor FLC (A)	Total Watts	Motor Rating HP @ 500V	Motor FLC (A)	Total Watts
3	5	68	60	110	316
5	9	76	75	125	458
7.5	15	88	100	165	607
15	27	135	125	206	673
20	34	164	150	243	866
25	43	161	200	330	1130
30	55	195	250	405	1413
40	70	267	300	480	1625
50	90	291	400	648	1722

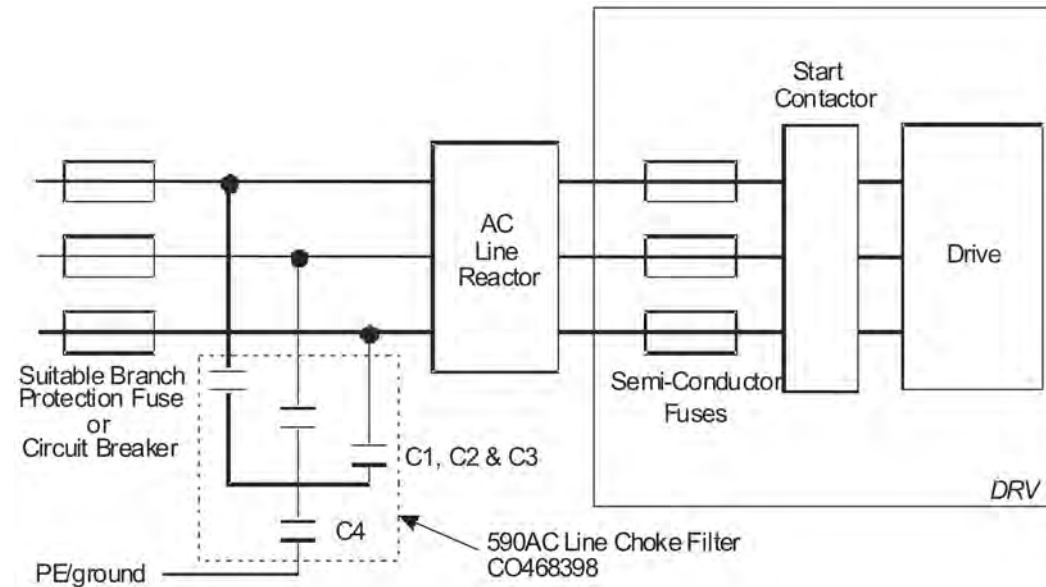
**Note:** Total Watts for 200 to 500 horsepower models can be reduced by 80 percent if the exhaust duct is used to vent the drive outside the enclosure.

## Line Reactor/Isolation Transformer

If no isolation transformer is used, we recommend that you always use the specified line reactor with the drive to provide a known supply impedance for effective operation of the thyristor transient suppression circuits. At least 2% line impedance should be provided in the supply side of the drive.

**Note:** On installations requiring compliance with EN61800-3 Table 11, you must fit capacitors between the phase and ground, before the specified Line Reactor. This applies to DRVs with an armature current <100A.

Refer to Appendix E: “Technical Specifications” - AC Line Reactor for selection details.



**Figure 3-1 AC Line Reactor and Capacitors fitted to Frame 1 (35A) & Frame 2 (40A & 70A) DRV**

Capacitor Reference Number	Capacitor Value/Type
C1, C2, C3	3.0µF 400V, EMI suppressor type Class X1
C4	1.0µF 400V, EMI suppressor type Class X1

Refer to Appendix E: “Technical Specifications” - AC Line Reactor for selection details.

# Electrical Installation

**IMPORTANT** Please read the Safety Information on page Cont. 3 & 4 before proceeding.

This Chapter deals only with a "general purpose" operation as a basic speed controller, because of the complexity of showing all possible configurations.

Special wiring instructions usually form part of a customer-specific system and connection details will be provided separately.

## **WARNING**

**Power terminals carry electrical voltage, which can be lethal. Never work on any control equipment or motors without first removing all power supplies from the equipment.**

**Make sure all wiring connections meet or exceed applicable local and National Electrical Codes.**

**Be sure to fit branch circuit and motor overload protection.**

---

## **Caution**

To avoid damaging the drive NEVER carry out high voltage resistance or dielectric strength tests without first completely disconnecting the drive from the circuit being tested.

---

## **Caution**

Incorrect wiring is a common cause of start up problems. If you have questions about wiring procedures, contact Parker SSD Drives Product Support.

---

## EMC Wiring Details

### Cabling Requirements

Cables are considered to be electrically *sensitive*, *clean* or *noisy*. You should already have planned your cable routes with respect to segregating these cables for EMC compliance. If not, refer to Appendix B: “Certification”.

If the drive is to be operating in a regenerating mode for extended periods acting as a load generator for another machine, it is advisable to fit additional protection in the armature circuit. A dc fuse or high speed circuit breaker will provide this protection. If in doubt, contact Parker SSD Drives.

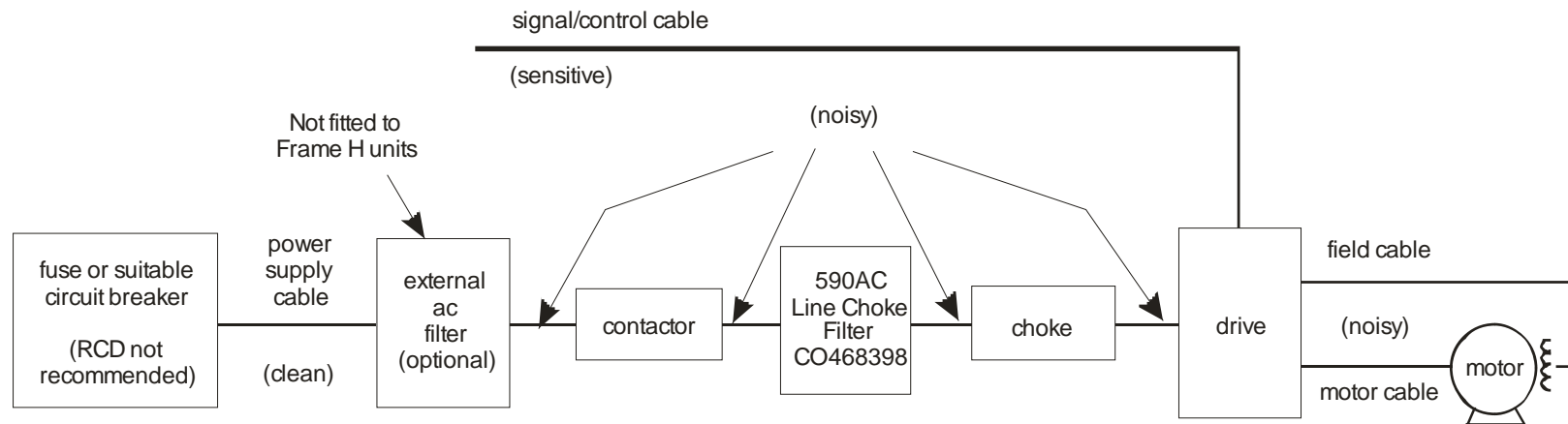


Figure 3-1 Cabling Requirements

### Cable Gland Requirements (Frame 1)

Use a metal gland to connect to the cubicle backplate, near the VSD (variable speed drive). It must be capable of securing a 360 degree screened connection to give EMC compliance. A 360 degree screened connection can be achieved as shown.

We suggest a rubber grommet should be fitted on holes where a cable gland is not used.

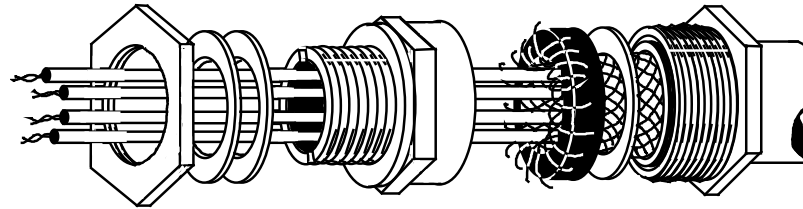


Figure 3-2 360 Degree Screened Connection

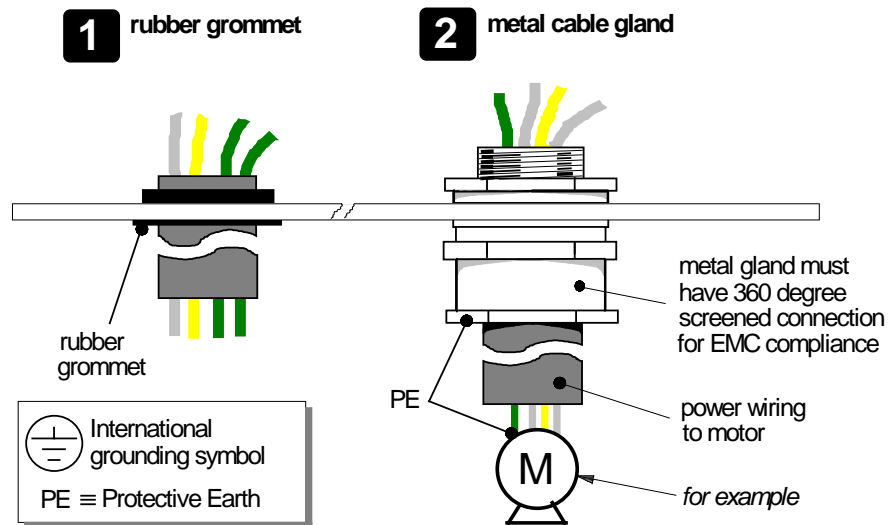


Figure 3-4 Cable and Screen Fixings

# 3-8 Installing the Drive

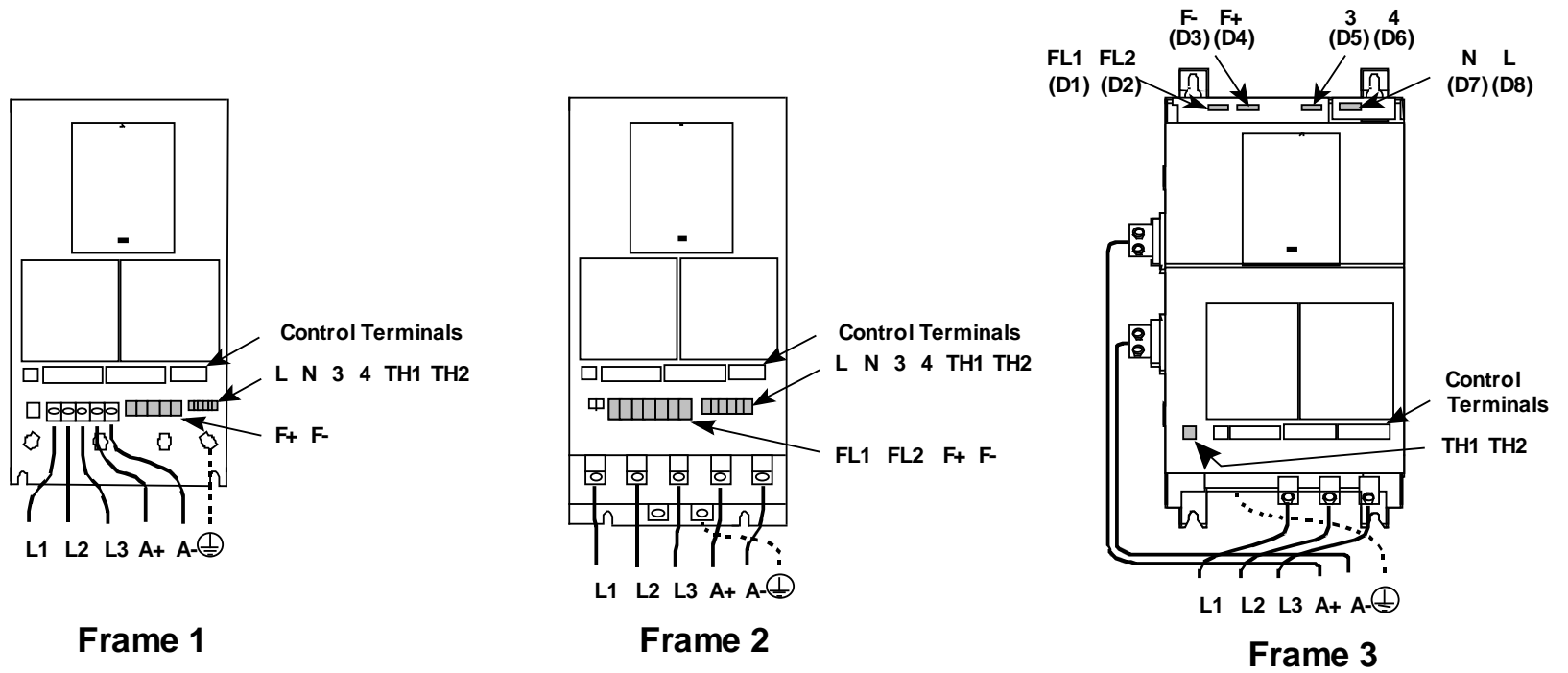
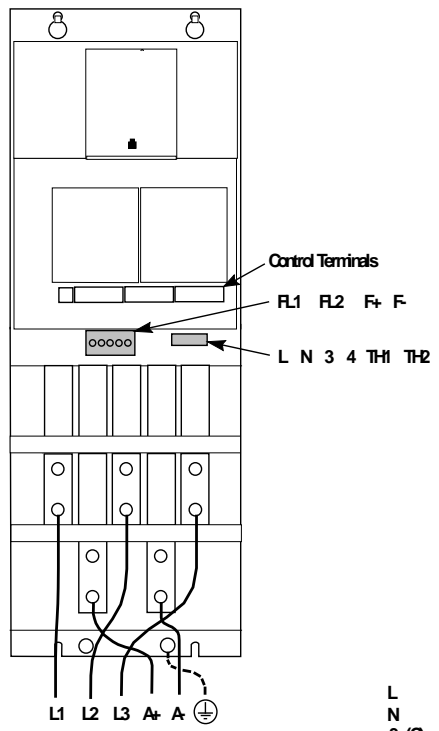


Figure 3-5 Power Connections



**Frame 4**

Note: On Frame 5 units the left hand unit is fitted with two A+ terminals, and the right hand unit has two A- terminals

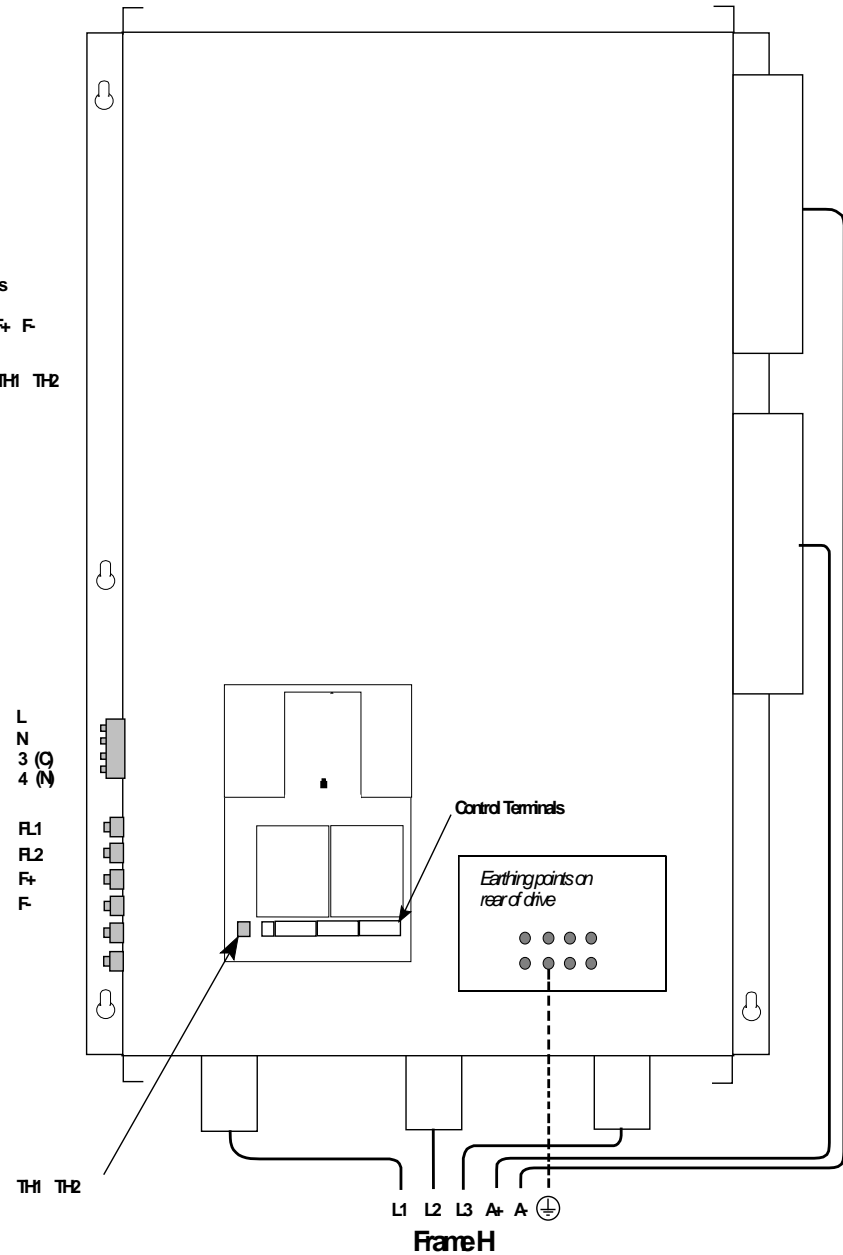


Figure 3-6 Power Connections continued



---

## Wiring Instructions - Minimum Connections

**NOTE** Refer to Appendix E: “Technical Specifications” for Terminal Information, Wires Sizes and Termination Tightening Torques.

**NOTE** A label on the DRV lists the tightening torque for all user terminals. Do not overtighten connections when installing wires.

The wiring procedures in this manual apply to a DC590+ DRV Digital drive configured for general-purpose speed control operation. This chapter describes the functionality using the default settings. Wiring configurations for custom systems or for optional applications are too numerous and complex to include here. For system configurations, refer to the schematics packaged with those systems.

**NOTE** The following sections describe connections shown in the Connection Diagrams located at the end of this chapter.

### Power Wiring

If you need electrical terminals for motor and supply connections, Parker SSD Drives has UL-approved crimp terminal kits available in the following armature current ranges:

Amps Terminal Kit Catalog No.

13 955-CK13

35 955-CK35

50 955-CK50

66 955-CK66

98 955-CK98

122 955-CK122

164 955-CK164

---

### Caution

The semiconductor fuses fitted to *all* DC590+ DRVs protect only the SCRs in the drive and do *not* provide branch circuit protection. You *must* fit branch circuit protection to the incoming power supply.

---

The power wires must have a minimum rating of 1.1 x FULL LOAD CURRENT.

## Protective Earth/Ground (PE)

### IMPORTANT

*The drive and filter (if fitted) must be permanently earthed/grounded. Each conductor used for permanent earthing/grounding must individually meet the requirements for a protective earth/ground conductor.*

For installations to EN 60204 in Europe:

- For **permanent earthing**, the drive requires either two individual incoming, protective earth conductors ( $<10\text{mm}^2/6\text{AWG}$  cross-section), or one conductor ( $\geq 10\text{mm}^2/6\text{AWG}$  cross-section) connected to an independent earth/ground point near the drive. Refer to Appendix B: "Certification" - EMC General Installation Considerations.



The DC590+ DRV DC Digital Drive has ground terminals for each incoming and outgoing supply. A substantial connection must be made to the incoming supply ground terminal near terminals L1, L2, L3. The ground terminals at the bottom of the drive can be used for armature ground and grounding the auxiliary 120 VAC loads.

## 3-Phase Mains Supply (L1, L2, L3)

Connect the main AC power supply to terminals L1, L2 & L3 through the correctly sized branch circuit protection and an AC line reactor or dedicated drive isolation transformer.

### IMPORTANT

*You must provide branch circuit protection, rated for the supply voltage:  $AC\ Current = 0.83 \times DC\ Armature\ Current$*

## 1-Phase Auxiliary/Control Supply (L, N)

Frame 1 and 2 DC590+ DRVs require an external 120 VAC supply to power the control electronics. This supply is fused at 3 Amps. Connect to terminals L and N on the terminal board. These drives can also be ordered with an internal Control Transformer option. This option is described on page 3-44.

Frame 3 and larger DRVs have an integral 120 VAC control transformer. No external connections are required. It works on 230 and 460 VAC supplies by changing the taps on the transformer.

## Motor Armature (A+, A-)

### NOTE

**If in doubt about connection of the DC motor to the drive, check with Parker SSD Drives.**

Connect the motor armature to terminals A+ and A-. To comply with national and local electrical codes, external DC overload protection must be provided.

Connect an earth from the motor to the DRV grounding point. Run the motor protective earth/ground connection in parallel with the motor supply conductors, ideally in the same conduit/screen/armour.

Make screen connections between the motor casing and the earth connection on the terminal rail. Refer to Appendix B: "Certification" - EMC General Installation Considerations.

If you are using dynamic braking to stop the motor, connect the negative armature lead through a suitably rated dynamic brake resistor to terminal DB+. Refer to Dynamic Braking Option below.

## 3-12 Installing the Drive

### Dynamic Braking Option (DB+)

This option provides a limited braking ability, primarily for use as an emergency stop, by using the external contactor to switch a resistor across the motor armature. The drive will dynamic brake if wired for coast stopping and a properly sized resistor is connected. In DRV Frames 3 and 4 through to 250Hp, the contactor includes a normally closed, dynamic braking DC contactor pole rated to carry full load armature current upon closing.

**NOTE** The enable input C5 must be True (24V) for the drive to run. If using the Dynamic Braking Option, remove the jumper across control terminals C5, C9 on the drive.

The braking current rating of the contactor is 150% of armature current. Contact Parker SSD Drives for a range of resistors meeting NEMA ICS 3-302.62.

The start-stop circuitry should be designed to prevent the motor from restarting and the pole from opening until *after* the motor reaches zero speed.

**NOTE** The dynamic brake contactor pole is rated to make, but not interrupt DC motor current. To avoid damaging the contact, interlock the drive's ZERO SPEED output signal to the DRIVE START logic to prevent the drive from restarting until the motor has reached standstill.

If in doubt about the connection of the DC motor to the drive check with Parker SSD Drives.

### Motor Field Connections (F+, F-)

#### WARNING

**The field bridge is supplied from the input side of the main contactor and is live whenever power is applied to the drive. Remove power completely to isolate the field.**

Connect the motor field (-) to terminal F- and field (+) to terminal F+ (Figure 3.3) for standard motors (300VDC fields on 500VDC armatures and 150VDC on 240VDC armatures are typical). If the motor requires a field supply greater than the drive can product, refer to the following External Field Supply section.

For EMC, make screen connections, as shown in the relevant Connection Diagram at the end of this chapter, between the motor casing and a ground connection on the DRV. Refer to Appendix B: "Certification" - EMC General Installation Considerations.

Make no connections to these terminals: if the motor has no field connections, if it is a permanent magnet motor, if the field is derived externally.

In these cases, you will be asked to set the FIELD ENABLE parameter to Disable during the set-up procedure in Chapter 4.

## External Field Supply (FL1, FL2)

### WARNING

**Verify that power is disconnected before proceeding.**

This connection is not available on Frame 1 DRVs. Frame 7 DRVs always require an external field supply. If this option to convert to using an external ac field is not required, do not connect to these terminals.

Occasionally, motors require field voltages greater or smaller than can be supplied by the main L1, L2 and L3 supply. When required, connect the external field supply to terminals FL1 and FL2. Always derive the supply from L1 and L2 phases directly, or indirectly through a single-phase transformer. The required field voltage determines the size of the external field supply.

---

### Caution

An "out-of-phase" external supply can blow fuses and cause faulty operation. The AC field supply is normally fed internally from L1 and L2. Some motors require field voltages greater than the mains supply at L1, L2, and L3. This external field supply must be "in phase" with the main supply. The supply connection to terminal FL1 must be in phase with the supply on terminal L1 and FL2 must be in phase with the supply on L2.

---

Depending on the drive's field regulator rating, reconnect the field supply jumpers on the drive as described below:

1. FOR FRAME 2 MODELS (10A field, maximum):

- Move the jumper from position 1 to position 2.
- Externally protect the field supply with 10A semiconductor fuses rated for the supply voltage.

2. FOR FRAME 3 MODELS (20A field, maximum):

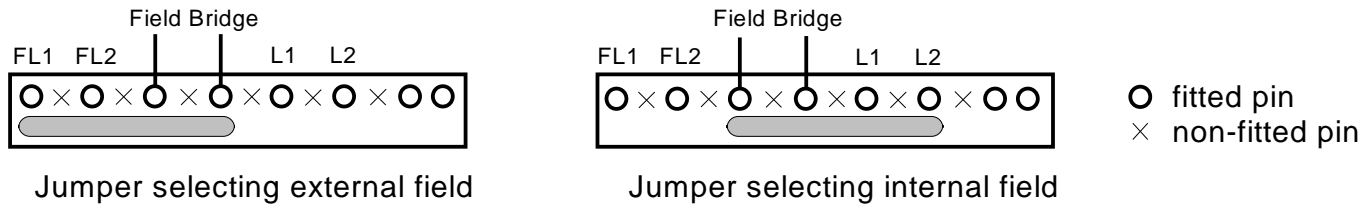
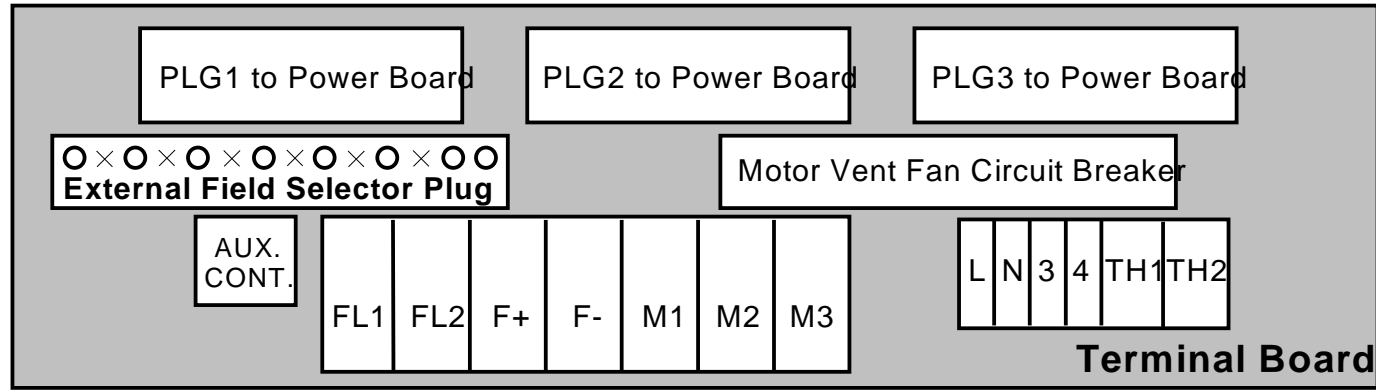
- Move the RED wire from internal terminal F16 to F19 and move the YELLOW wire from internal terminal F8 to F18.
- Externally protect the field supply with 10A semiconductor fuses rated for the supply voltage.

3. FOR FRAME 4 & 5 MODELS (30A field, maximum):

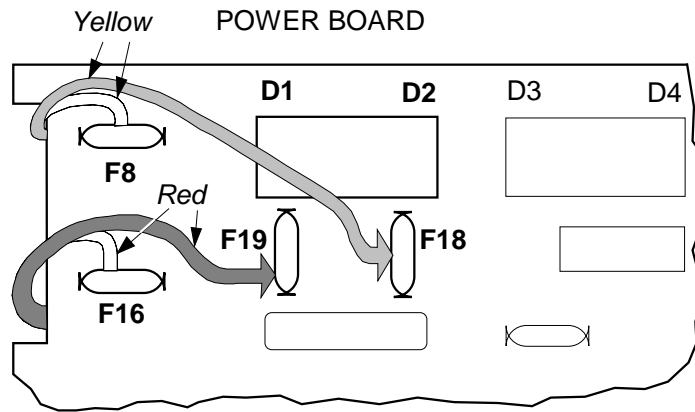
- Move the RED wire from internal terminal F2 to F3, EX L1, and the YELLOW wire from internal terminal F5 to F6, EX L2.
- Externally protect the field supply with 30A semiconductor fuses rated for the supply voltage.

4. FOR FRAME 6 & 7 MODELS (60A field, maximum), refer to Appendix E : "Technical Specifications" - Terminal Information (Power Board).

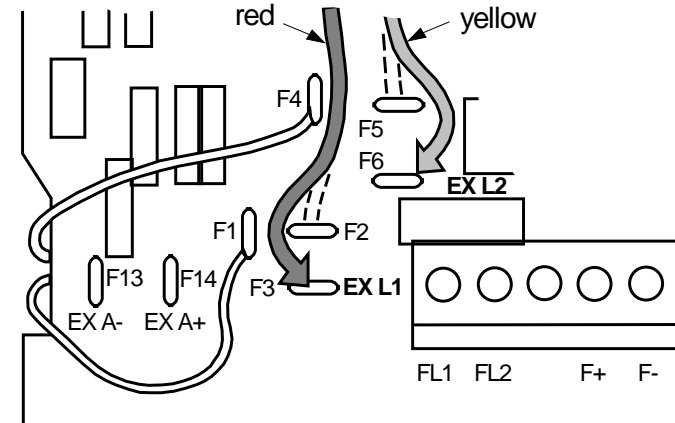
# 3-14 Installing the Drive



## External Field Supply Connections - Frame 2

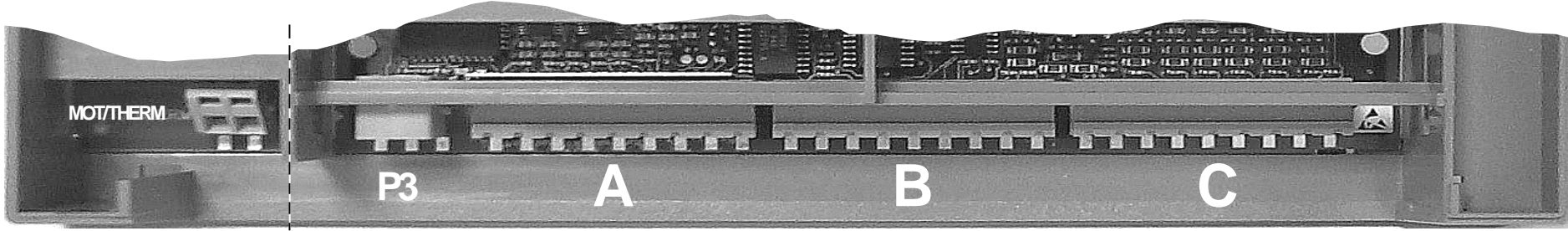


External Field Supply Connections - Frame 3

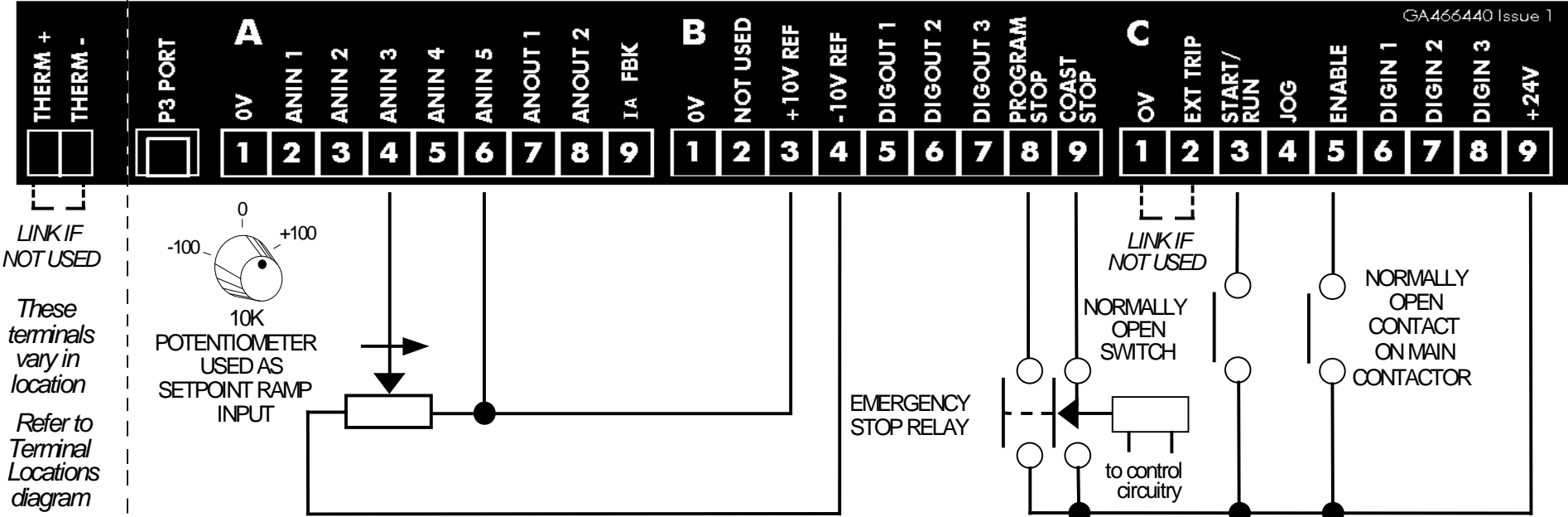


External Field Supply Connections - Frame 4 (5)

# Control Wiring



GA466440 Issue 1



LINK IF NOT USED

These terminals vary in location

Refer to Terminal Locations diagram

All connections made to terminal blocks A, B and C must be isolated signal voltages. Never perform high voltage resistance or dielectric strength tests without first completely disconnecting the drive from the circuit being tested.

To comply with EMC requirements, use screened control cables with a minimum cross-section area of 0.75mm<sup>2</sup> (18AWG).

Control wiring should be bundled and routed to the left side of the drive so that the control door on Frames 3, 4, 5 & H is free to open.

## 3-16 Installing the Drive

ENABLE

### Enable (C5)

On Frames 1 and 2, terminal C5 (ENABLE) is connected to terminal C9 (+24V). Internally, terminal C5 is connected in series with a normally open auxiliary contact on the DRV main contactor.

On Frames 3 and larger, terminal C5 (ENABLE) is connected to terminal C9 (+24V) internally through a normally-opened auxiliary contact on the DRV main contactor.

The drive remains disabled until the main contactor poles are closed.

#### WARNING

**The drive must be disabled and power should be removed before servicing the equipment. First stop the drive and make sure the main contactor has de-energized, then remove power.**

THERM

### Thermistor (TH1, TH2)

Connect the motor thermistor to terminals TH1 and TH2.

#### NOTE

**Terminals TH1 and TH2 must be connected together if the sensors are not fitted. This will prevent the drive from tripping the motor temperature alarm (THERMISTOR). The alarm cannot be inhibited in software.**

EXT TRIP

### External Trip (C1, C2)

This terminal provides an external trip facility to any normally closed contact. For example, if the motor has an external blower motor, wire an auxiliary contact from the blower starter's overload trip circuitry between terminals C1 and C2.

#### NOTE

**Terminals C1 and C2 must be connected together if an external trip is not used. This will prevent the drive from tripping the THERMISTOR alarm. The alarm cannot be inhibited in software.**

PROGRAM  
STOP

### Program and Coast Stop (B8, B9)

For a regenerative emergency stop (regenerative units only) connect terminal B8 (PROGRAM STOP) to terminal C9 (+24VDC) through a normally open contact of an emergency stop relay. Also connect terminal B9 (COAST STOP) to terminal C9 through a time-delayed off, normally open contact on the same emergency stop relay. Activating the E-Stop circuit removes 24 VDC from B8 and regenerates the motor power back into the main supply. The delayed-off contact on B9 (COAST STOP) acts as a fail safe, allowing the drive to coast to stop after the time delay.

For non-regenerative drives or for coast stopping with regenerative models, permanently connect together terminal B8 to B9 and connect terminal B9 to +24 VDC (terminal C9) through a non-delayed, normally-open contact of the emergency stop relay. Upon activating an emergency stop condition, the drive will coast stop immediately.

COAST  
STOP

#### WARNING

**The emergency stop relay should not be considered part of the normal sequencing of the system and should be triggered only in circumstances involving equipment damage or safety.**

ANIN 5

## Asymmetric Current Limits (A5, A6, B3, B4, C6)

For asymmetric current limits, connect terminal C6 (CURRENT CLAMP SELECT) to C9 (24VDC), which sets parameter BIPOLAR CLAMPS to TRUE. This lets terminal A5 control the negative current clamp and terminal A6 control the positive current clamp. Connect terminal A5 (ANALOG INPUT 4) to terminal B4 (-10 VDC REFERENCE) and connect terminal A6 (ANALOG INPUT 5) to terminal B3 (+10 VDC REFERENCE). This sets the drive's positive and negative current limit clamps to +100% and -100% respectively for forward and reverse motor operation.

To control the positive current limit externally, connect a 10k  $\Omega$  potentiometer between terminal B3 (+10 VDC REFERENCE) and terminal B1 (0 VDC). Connect the wiper to terminal A6. You can then adjust the positive current clamp from 0 to 100%.

To control the negative current limit externally, connect a 10k  $\Omega$  potentiometer between terminal B4 (-10 VDC REFERENCE) and terminal B1 (0 VDC). Connect the wiper to terminal A5. You can then adjust the negative current clamp from 0 to -100%.

For greater adjustment range, you can adjust the scaling factor for both current limits up to 200% by setting SETUP PARAMETERS::CURRENT LOOP:: CUR.LIMIT/SCALER.

ANIN 3

+10V REF

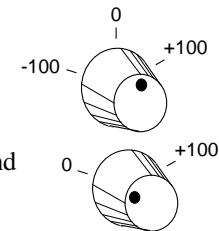
-10V REF

0V

## Speed Demand (A2, A3, A4, C8)

For normal operation, connect the speed demand signal to terminal A4 (RAMP SETPOINT). This input is scaled so that +10 VDC input equals maximum forward speed demand (+100%), and -10 VDC input equals maximum reverse speed demand (-100%).

Connect the ends of an external 10k $\Omega$  potentiometer to terminal B3 (+10 VDC REFERENCE) and terminal B4 (-10 VDC REFERENCE) and the wiper to terminal A4. For non-reversing applications, the speed demand needs only to operate between 0 and +10 VDC. Connect the high, or clockwise, end of the potentiometer to B3 and the low, or counter clockwise, end to the 0 VDC terminal, A1 (SIGNAL GROUND).



Terminal A2 (SPEED SETPOINT NO. 1) is an additional, non-ramped speed demand input which sums with the drive's other speed inputs. Connect your speed demand to this terminal for non-ramped speed control. This is often used as a speed trim signal.

Terminal A3 (SPEED SETPOINT NO. 2 or CURRENT DEMAND) is a hardwired, high-speed input, which functions either as a non-ramped speed or current demand. The state of control terminal C8 (I DMD. ISOLATE) determines the operating mode of the input. When tied to +24 VDC (terminal C9), A3 is a direct current demand input to the drive's current loop. When terminal C8 is left open-circuited, A3 is a non-ramped, speed demand input and sums with the other drive speed loop inputs.

START/  
RUN

## Start/Stop Input (C3)

Connect terminal C3 (RUN) to C9 (+24V) through a normally open contact to provide normal start/stop control. When the contact is open, the drive will attempt to perform a controlled stop. When it is closed, the drive will start.

## Jog Input (C4)

Terminal C4 (JOG) is connected through a normally open contact to terminal C9 for jog applications. Interlock the jog relay contact with the run relay coils as shown in the relevant Connection Diagram at the end of this chapter.

## Armature Current Feedback Output (A9)

You can connect a meter to terminal A9 (ARMATURE CURRENT) to monitor the motor DC armature current. The output is hardwired and *not* software configurable. Refer to Appendix E: "Terminal Information – Control Board" for the terminal's output rating and signal



## Additional Control Connections

**NOTE** Appendix E: "Technical Specifications", Terminal Information - Control Board lists details for all control terminals.

ANIN 1

### Speed Setpoint No. 1 (A2)

This is another choice of input for the speed setpoint. It bypasses the "Setpoint Ramp Generator" used by terminal A4 (ANIN3), and should be used if direct control is required. There may be some latency in the signal because of the processing possibilities.

**NOTE** If more than one speed setpoint is used, they are additive.

ANIN 2

DIGIN 3

### Speed Setpoint No. 2/Current Demand (A3) and Current Demand Isolate (C8)

Terminal A3 (Analog Input 2) is a dual function terminal, either as "Speed Setpoint No. 2" (this is a direct signal with minimum processing) or "Current Demand". This function is selected by mode switch control terminal C8, "Current Demand Isolate". Refer to Appendix E: "Technical Specifications" - Terminal Information-Control Board for more information.

**NOTE** If more than one speed setpoint is used, they are additive.

ANIN 4

DIGIN 1

### Auxiliary Current Clamp -ve (A5) and Current Clamp Select (C6)

Current Clamp (C6) configures Auxiliary Current Clamp -ve. If terminal C6 = 0V, then the drive operates with a unipolar current limit provided at terminal A6, Main Current Clamp +ve. However, if terminal C6 = 24V, then the drive operates with a bipolar current limit; a positive current clamp is provided at terminal A6, Main Current Clamp +ve, a negative current clamp is provided at terminal A5, Auxiliary Current Clamp -ve.

ANOUT 1

### Speed Feedback (A7)

This is an instrument output to indicate the speed of the motor. The signal comes from tag 62 in the speed loop.

ANOUT 2

### Total Speed Setpoint (A8)

This is an instrument output that indicates the total speed setpoint (tag 63). This is the sum of all speed setpoint signals into the speed loop.

IA FBK

### Current Meter Output (A9)

This is an instrument output to indicate the drive current.

DIGOUT 1

DIGOUT 2

DIGOUT 3

### Zero Speed, Drive Healthy, Drive Ready (B5, B6, B7)

These digital output terminals provide a +24V dc output signal under certain conditions. They can drive external relays, PLC inputs, etc. This used to help safely start and stop the drive.

These are configurable outputs and can be used as required in the control system design, i.e. cubicle door lamps, connection to a suitable PLC.

AT ZERO SPEED – When the drive speed feedback drops below the zero speed threshold, terminal B5 will output 24 VDC.

DRIVE HEALTHY – When there are no software or hardware alarms and terminal C3 (RUN) is ON or when C3 is OFF, terminal B6 will output 24 VDC. This is the unlatched health signal in the drive.

DRIVE READY – When there are no software or hardware alarms and terminal C3 (RUN) is ON, terminal B7 will output 24 VDC

JOG

### Jog (C4)

This is a one-button function for positioning the motor at a pre-determined speed.

DIGIN 2

### Ramp Hold (C7)

When 24 VDC is connected to C7, the ramp speed setpoint (terminal A4) is held at its last value. When the 24 VDC is removed, the ramp continues to the setpoint from terminal A4.

## Technology Box Option (H1 - H6)

When the option is fitted to the drive, it provides terminal block H which allows drives to be connected together to form a network.

Refer to the appropriate Technical Manual supplied with the Technology Box.

## Motor Field Connections

### WARNING

**Isolate the drive before converting to internal/external supply.**

The FIELD CONTROL function block controls the motor field. The FLD CTRL MODE parameter allows you to select either Voltage or Current Control mode.

- In Voltage Control mode, the FLD.VOLTS RATIO parameter is used to scale the motor field output voltage as a percentage of the input supply voltage.
- In Current Control mode, the SETPOINT parameter is used to set an absolute motor field output current, expressed as a percentage of the calibrated field current (IF CAL).

## Internal/External Supply (Frames 2, 3, 4 & 5)

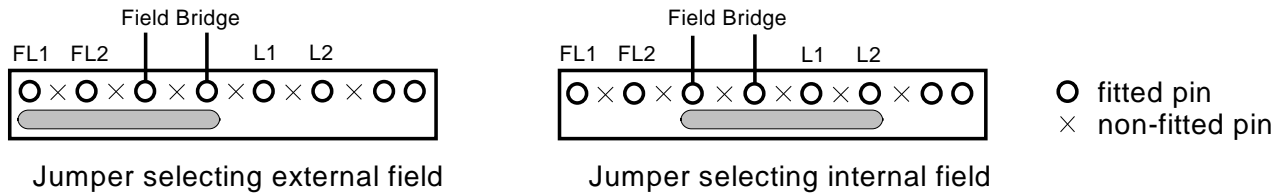
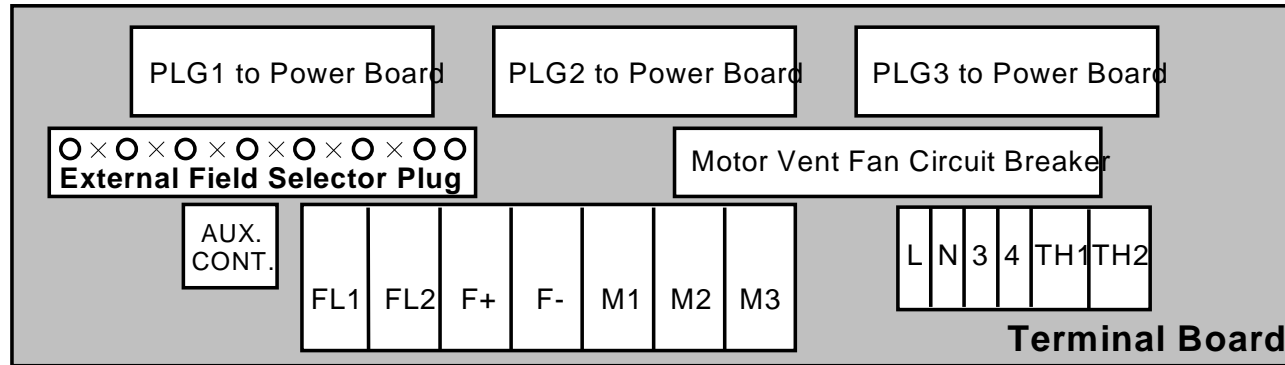
### NOTE

**The Frame 1 unit uses only an internal motor field supply. The Frame 7 unit uses only an external motor field supply. For information about the following terminal/power boards refer to Appendix E: “Technical Specifications” - Power Board Types, and Terminal Information (Power Board).**

The internal motor field is more widely used, however, there is provision on the unit for an external motor field supply to be connected (perhaps for where the field voltage is greater than the input voltage and therefore not attainable, or where the motor field is switched separately for convenience).

## FRAME 2 : Terminal Board - PCB Reference AH470330

The position of the jumper selects the board to use either an internal or external motor field.



### Internal Motor Field (default for this board)

Terminals F+ and F-, the motor field outputs, are energised when the 3-phase supply is connected to L1/L2/L3. Terminals FL1 and FL2 are not required. The internal motor field supply is fused by 10A fuses, FS5 & FS6.

### External Motor Field

Terminals FL1 and FL2 can be used for external ac supply connection for the Motor Field Supply. You should provide suitably rated external, fast-acting semi-conductor fusing, to a maximum of 10A.

## Caution

When using an external ac input it is important to have the correct phase relationship on the terminals. The supply must be derived from L1 (Red) and L2 (Yellow) phases directly or indirectly through a single-phase transformer.

L1 must be connected to FL1, and L2 connected to FL2.

The external field supply can now be connected and power restored to the drive.

## FRAME 3 : Power Board - PCB Reference AH385851

This power board can be altered for use with either an internal or external motor field supply:

### Internal Motor Field (default for this board)

Terminals D3 and D4, the motor field outputs, are energised when the 3-phase supply to L1/L2/L3 is energised and the internal motor field is used. Terminals D1 and D2 are not energised. The internal motor field supply is fused by the 10A fuses, FS2 & FS3.

### External Motor Field Connections

Terminals D1 and D2 on the Power Board can be used for an external ac supply connection for the Motor Field Supply.

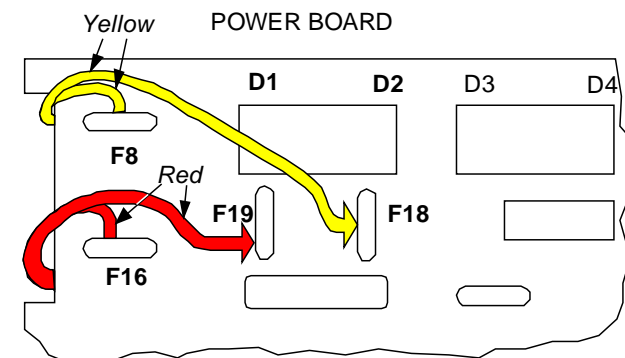
A simple re-wiring procedure disconnects the internal motor field supply and prepares terminals D1 and D2 for the external ac supply connection.

You should provide suitably rated external, fast-acting semi-conductor fusing, to a maximum of 10A.

### Re-Wiring Procedure

**WARNING**  
Isolate all power to the drive.

1. Loosen the control board fixing screws (2 off) and position the control board to allow access to the power board.
2. Remove the **red** link/jumper from the Faston connector “F16” on the left-hand side of the board and connect it to staging post “F19”, located below terminal D1.
3. Remove the **yellow** link/jumper wire from the Faston connector “F8” on the left-hand side of the board and connect it to staging post “F18”, located below terminal D2.



## Caution

When using an external ac input it is important to have the correct phase relationship on the terminals. The supply must be derived from L1 (Red) and L2 (Yellow) phases directly or indirectly through a single phase transformer.  
L1 must be connected to D1, and L2 connected to D2.

## 3-22 Installing the Drive

The external field supply can now be connected and power restored to the drive.

### FRAMES 4 & 5 : Power Board – PCB Reference AH466701

This power board can be altered for use with either an internal or external motor field supply:

#### Internal Motor Field (default for this board)

Terminals F+ and F-, the motor field outputs, are energised when the 3-phase supply to L1/L2/L3 is energised and the internal motor field is used. Terminals FL1 and FL2 are not energised. The internal motor field supply is fused by the 30A fuses FS1 and FS2.

#### External Motor Field Connections

Terminals FL1 and FL2 on the Power Board can be used for an external ac supply connection for the Motor Field Supply.

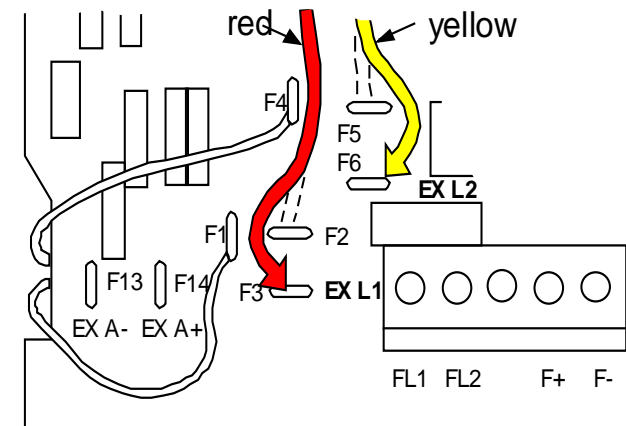
A simple re-wiring procedure disconnects the internal field supply and prepares terminals FL1 and FL2 for the external ac supply connection.

You should provide suitably rated external, fast-acting semi-conductor fusing, to a maximum of 30A.

#### Re-Wiring Procedure

#### WARNING Isolate all power to the drive.

1. Loosen the control board fixing screws (2 off) and position the control board to allow access to the power board.
2. Remove the **red** link/jumper from the Faston connector “F2” and connect it to the staging post “F3” nearby (EX L1).
3. Remove the **yellow** link/jumper wire from the Faston connector “F5” and connect it to the staging post “F6” nearby (EX L2).



#### Caution

When using an external ac input it is important to have the correct phase relationship on the terminals. The supply must be derived from L1 (Red) and L2 (Yellow) phases directly or indirectly through a single phase transformer.

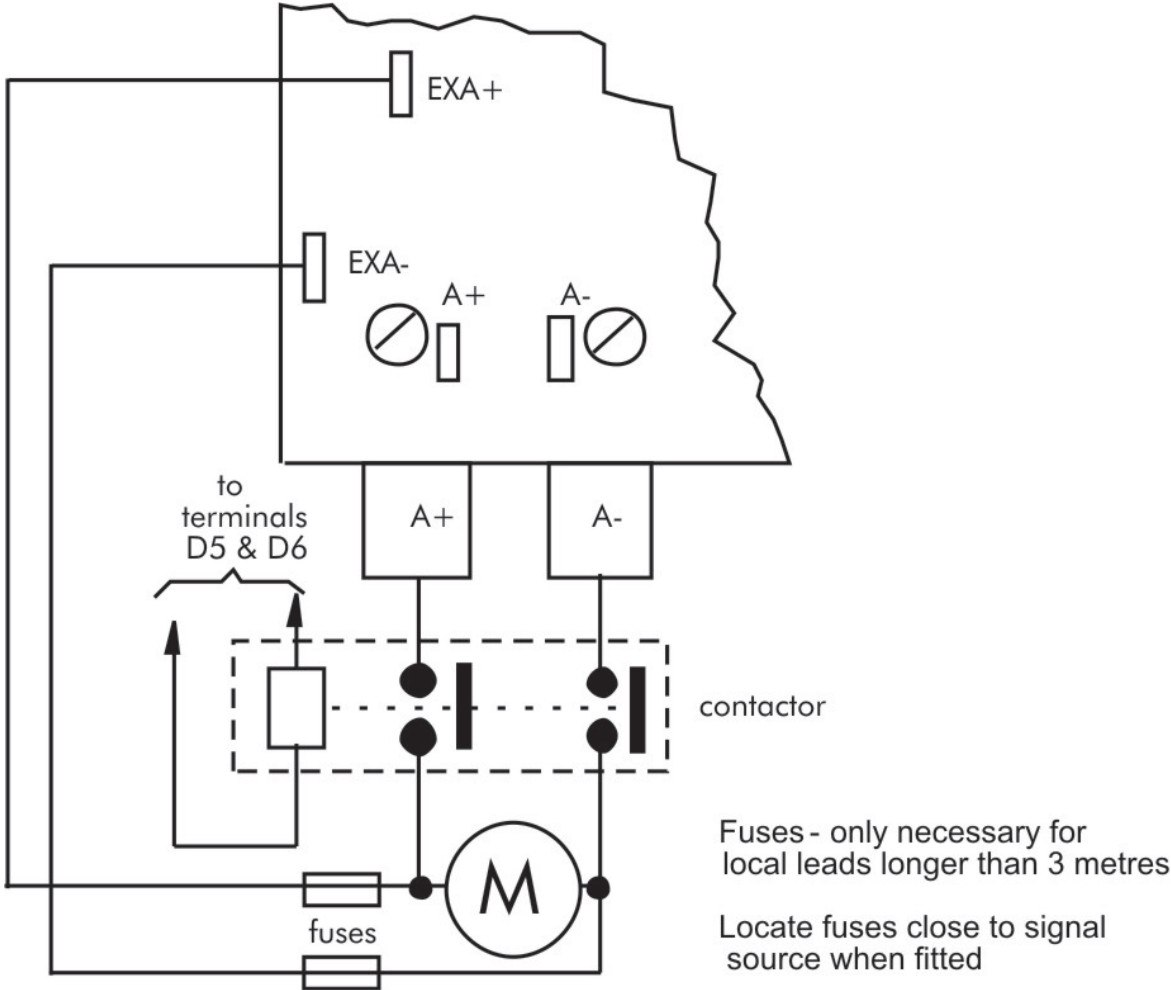
L1 must be in phase with FL1, and L2 must be in phase with FL2.

The external field supply can now be connected and power restored to the drive.

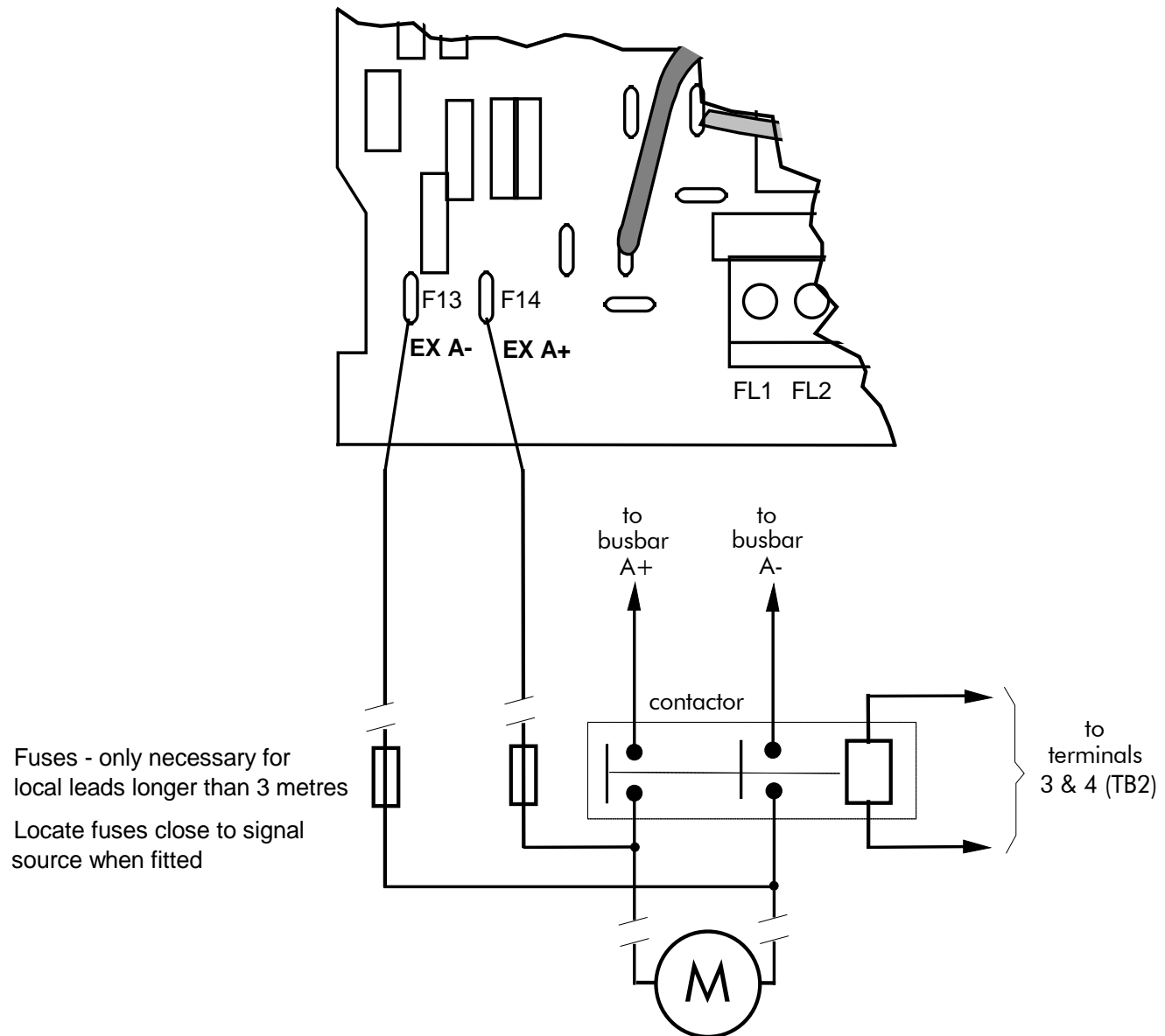
# DC Contactor - External Va Sensing

Connections are provided for external armature voltage sensing (at the motor) for when a dc contactor is used between the drive and motor.

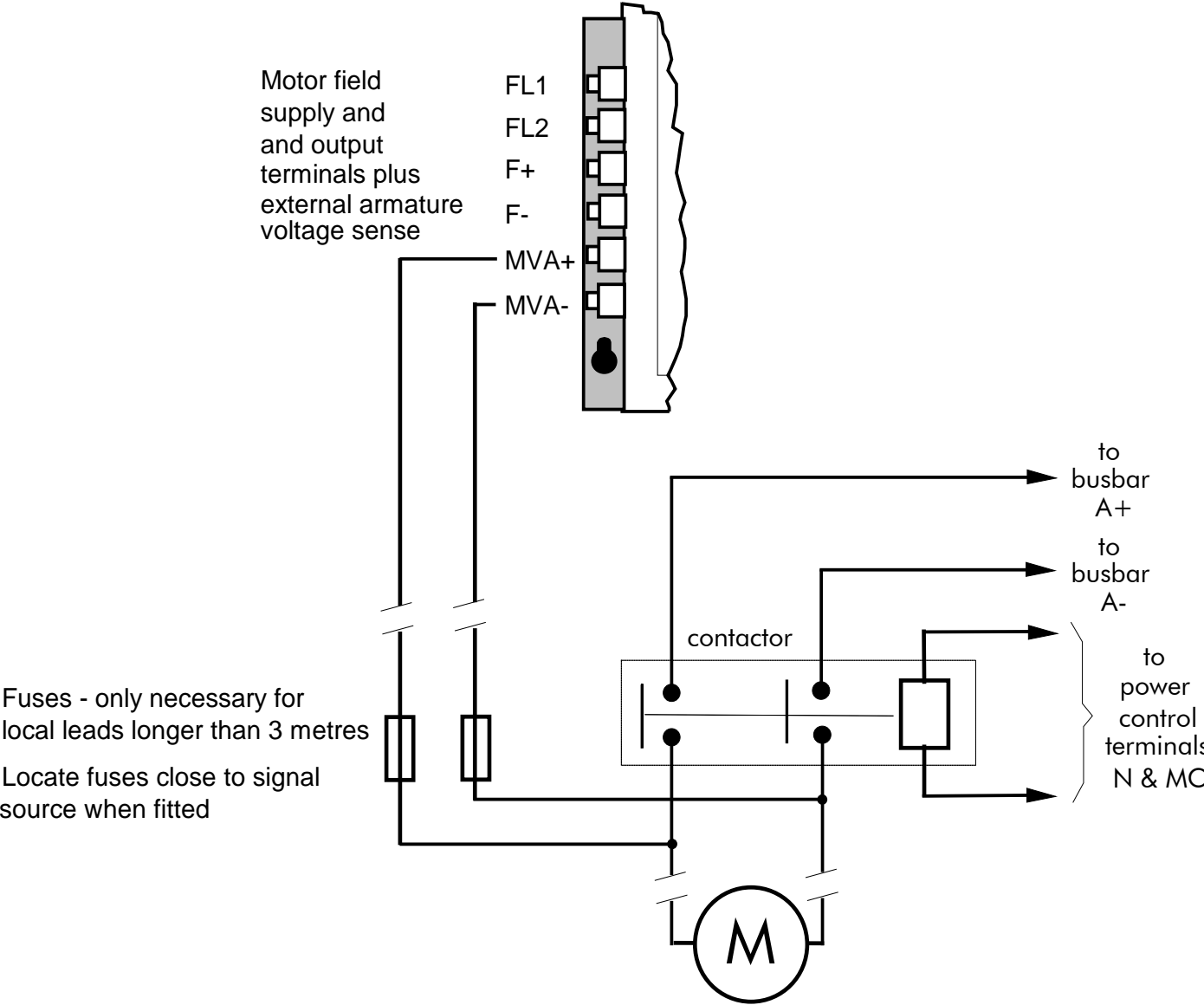
## Power Board - PCB Reference 385851 (Frame 3)



### Power Board – PCB Reference 466701 (Frames 4 & 5)



### External Connections (Frames 6 & 7)





## Power Board Circuit Descriptions

### AH470280U001, U002, U003, U004 (Frame 1)

**(2 Quad and 4 Quad)**

Power supplies for the controller are generated from the single phase auxiliary supply via a Switched Mode Power Supply. The incoming supply is directly rectified to provide a high voltage dc power rail. A high voltage transistor switches this rail on to the primary of a high frequency transformer, the output of which is rectified and smoothed to provide the dc power supply rails. The +15V dc rail is monitored via a reference element and a control signal returned via an opto-isolator to the control element of the high voltage switching transistor. The other dc rails (-15V & +24V dc) are generated via separate secondary windings which are rectified and smoothed, with a separate SMPS element providing a regulated +5V dc rail. The SMPS operates over a 0n input voltage range of 110V to 240V ac  $\pm 10\%$ , 50/60Hz.

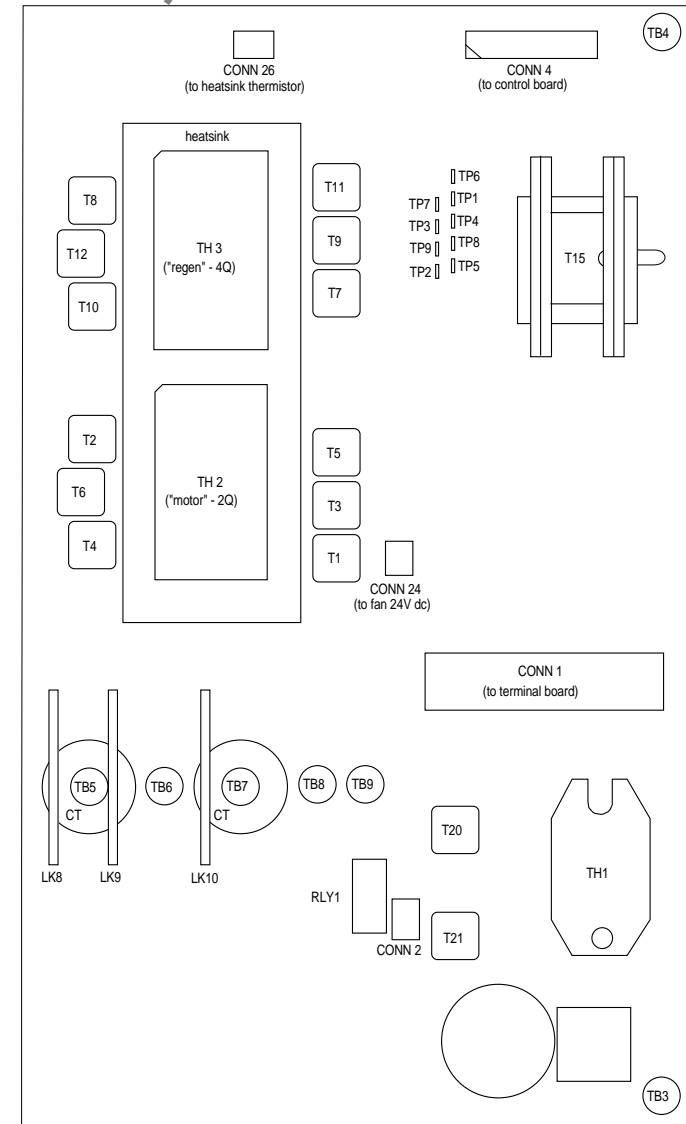
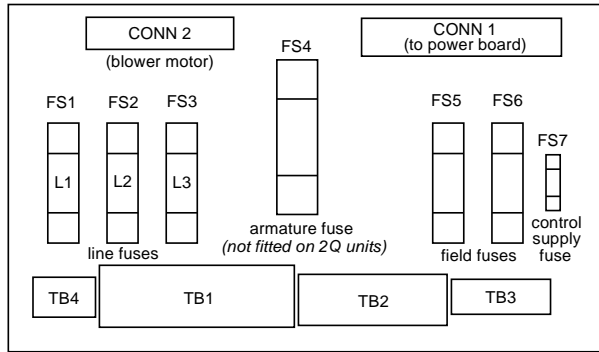
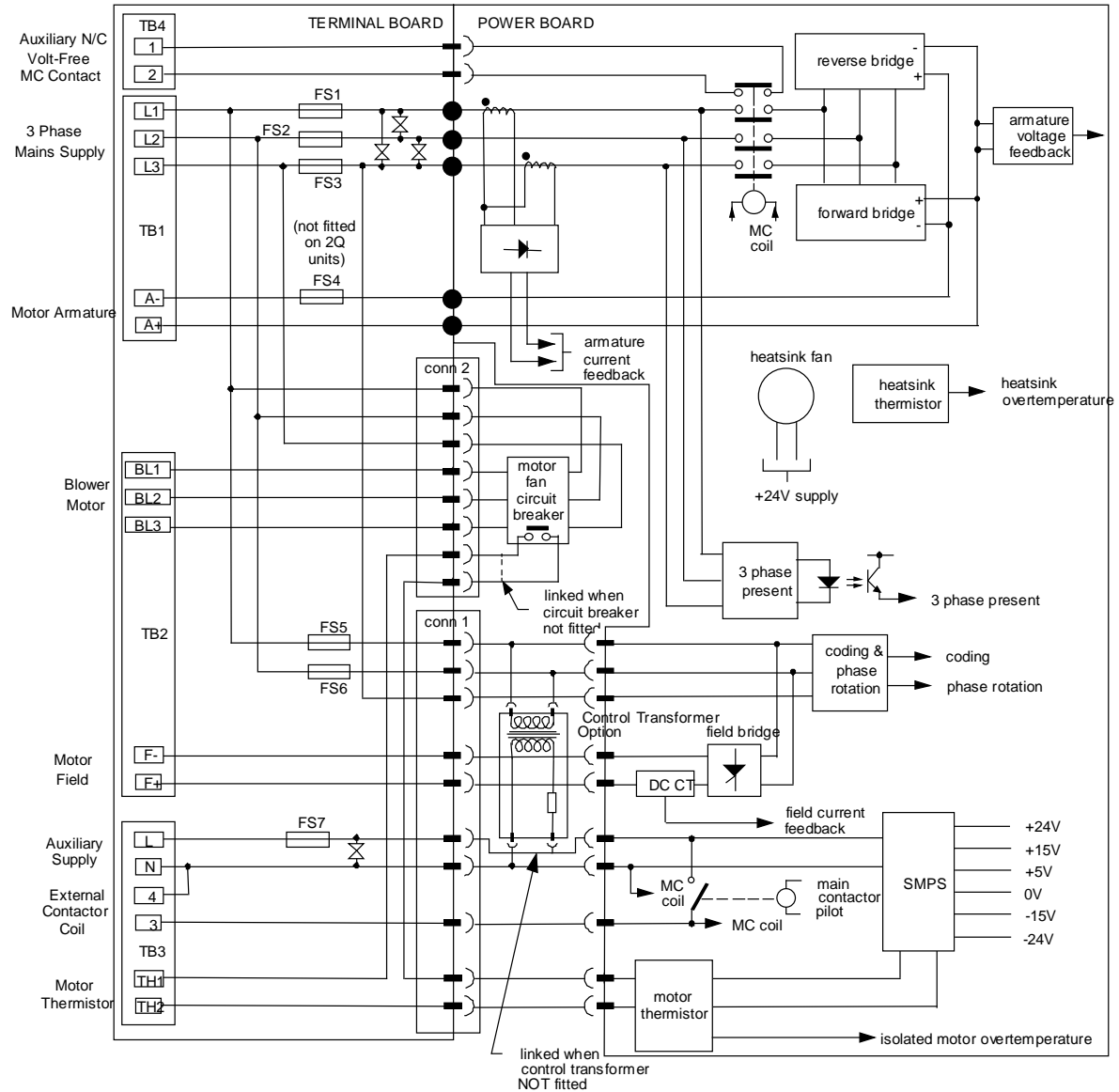


Figure 3- 7 590+ Power Board 4 Quad



**Figure 3- 8 Terminal Board – AH470364 (15-35A, 3-20Hp)**



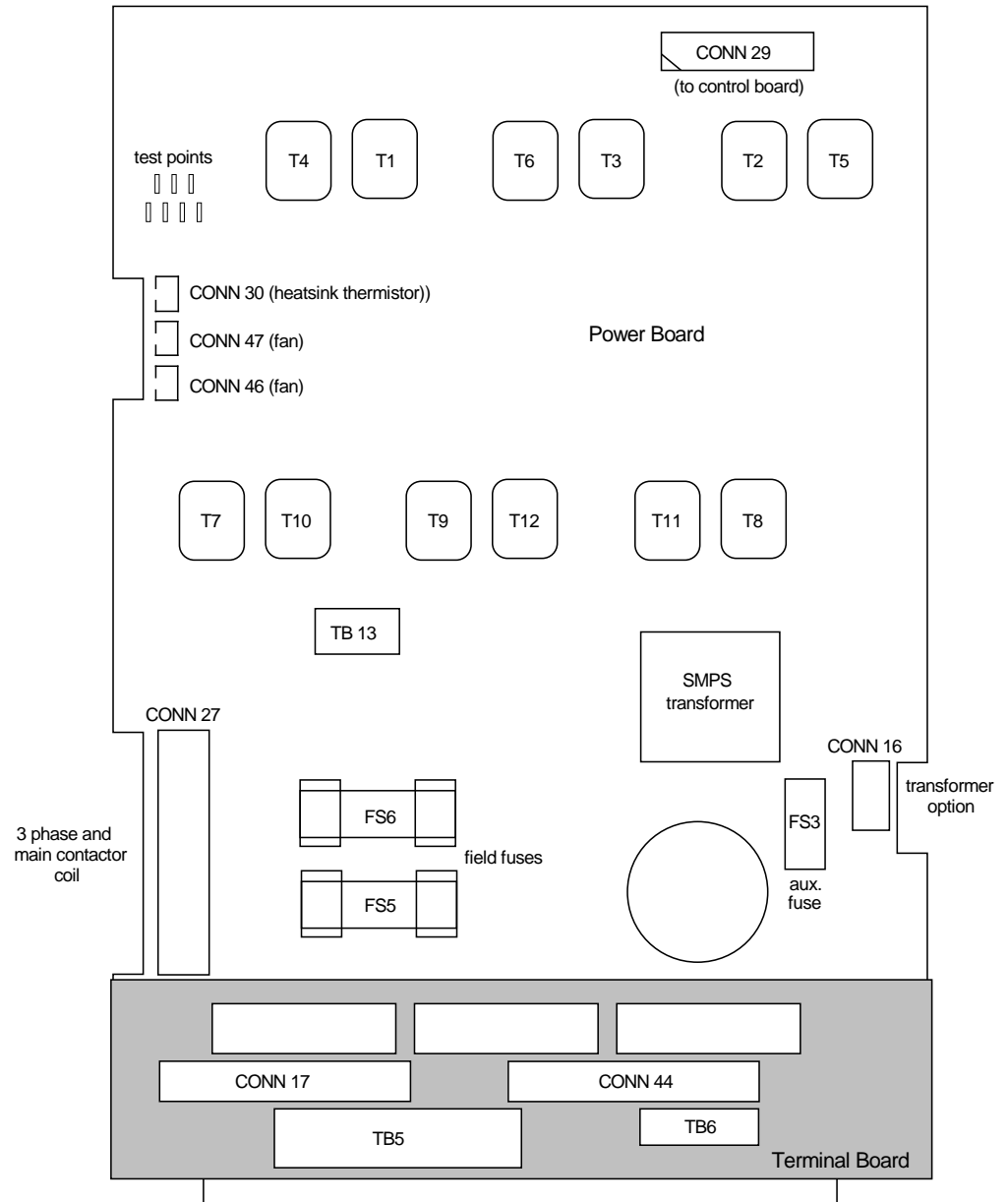
**Figure 3- 9 Connection Diagram for Power Board and Terminal Board - AH470280 (Frame 1)**

## AH470330 (Frame 2)

### (2 Quad and 4 Quad)

Power supplies for the controller are generated from the single phase auxiliary supply via a Switched Mode Power Supply. The incoming supply is directly rectified to provide a high voltage dc power rail. A high voltage transistor switches this rail on to the primary of a high frequency transformer, the output of which is rectified and smoothed to provide the dc power supply rails. The +15V dc rail is monitored via a reference element and a control signal returned via an opto-isolator to the control element of the high voltage switching transistor. The other dc rails (-15V & +24V dc) are generated via separate secondary windings which are rectified and smoothed, with a separate SMPS element providing a regulated +5V dc rail. The SMPS operates over an input voltage range of 110V to 240V ac  $\pm 10\%$ , 50/60Hz.

**Figure 3- 10 590+ Power Board  
4 Quad (AH470330)**



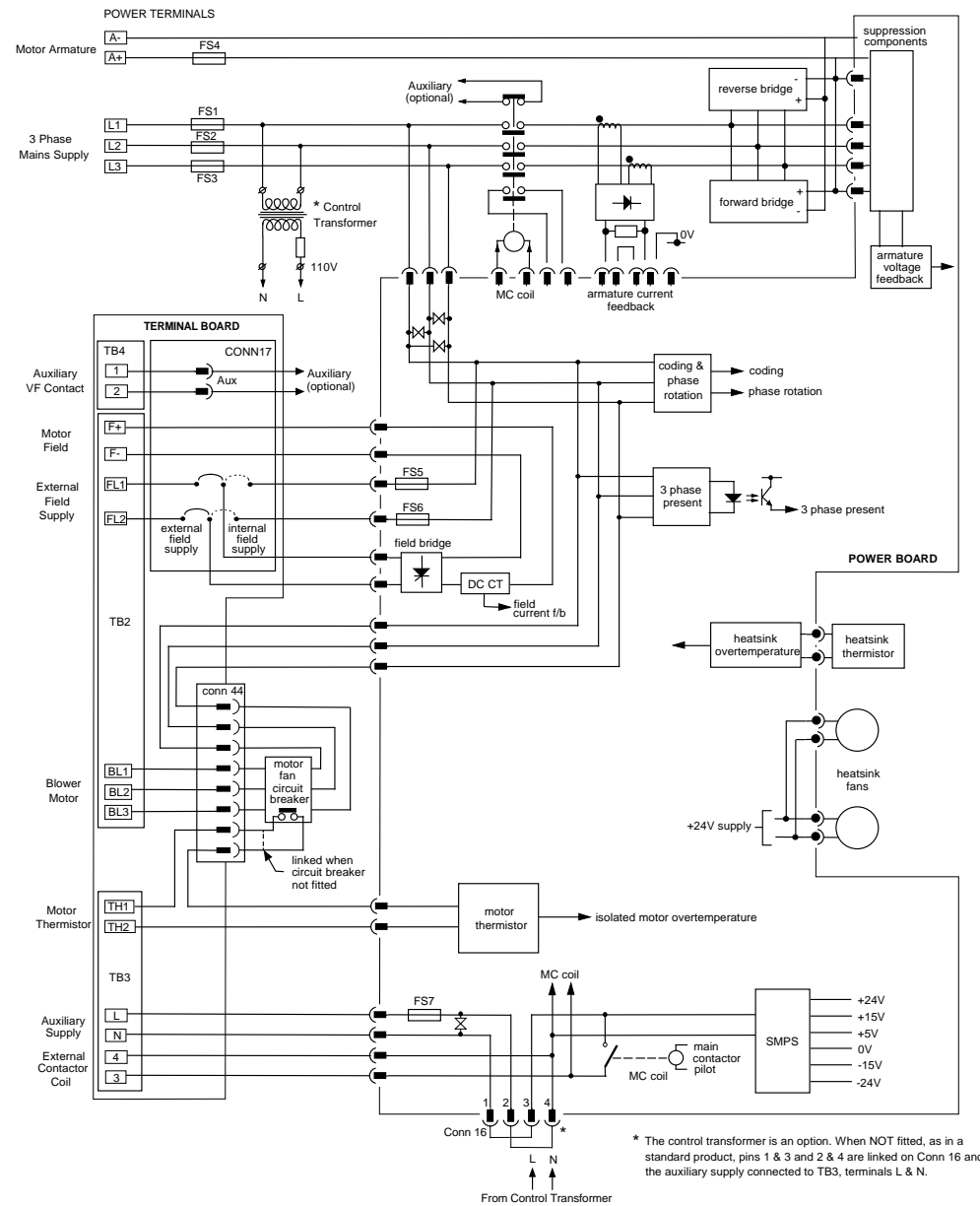
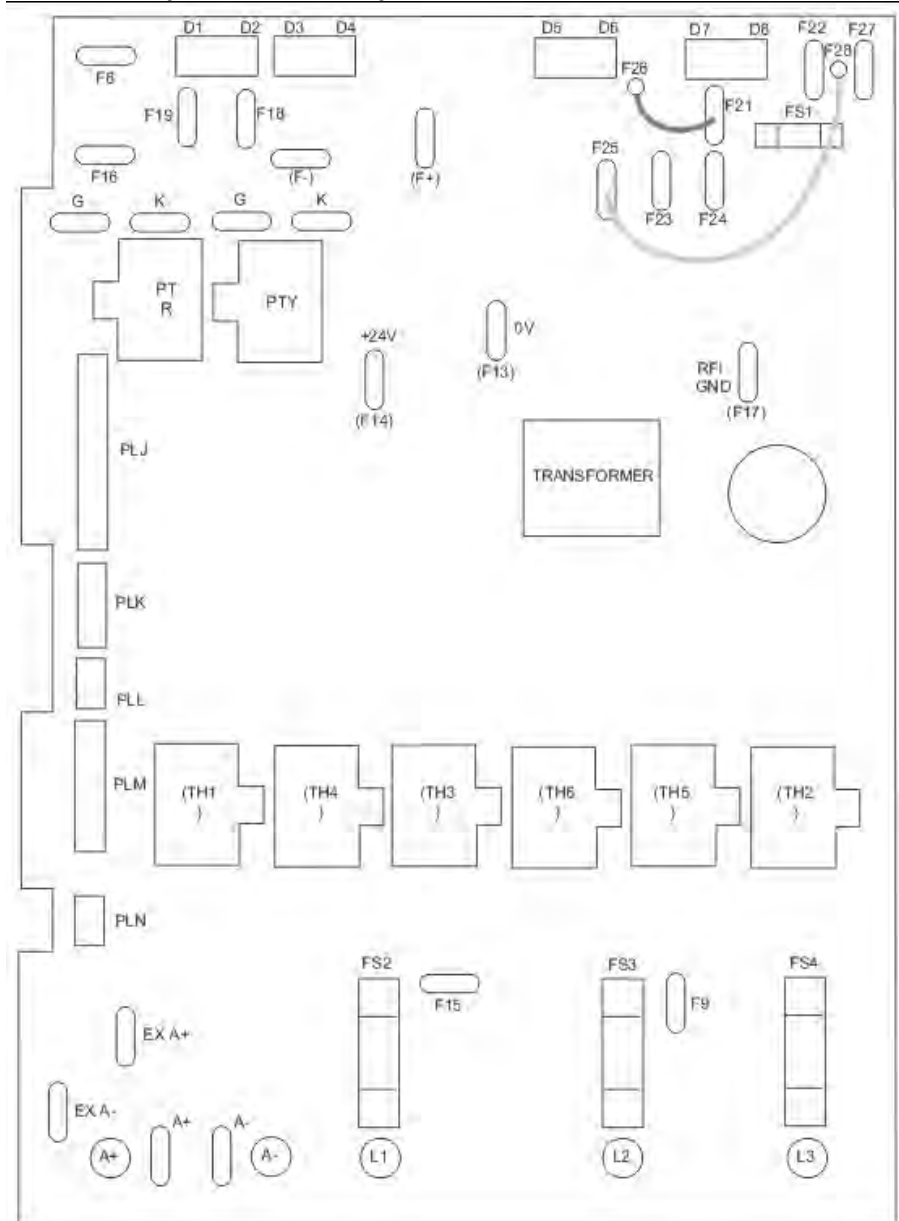


Figure 3- 11 AH470330 (Frame 2)

### AH385851U002, U003, U004, U005 (Frame 3)

**(590+ - 4 Quad, 591+ - 2 Quad; Low and High Volt)**  
 Power supplies for the controller are generated from the single phase auxiliary supply via a switched mode power supply. The incoming supply is directly rectified to provide a high voltage dc power rail. A high voltage transistor switches this rail on to the primary of a high frequency transformer, the output of which is rectified and smoothed to provide the dc power supply rails. The +5V dc rail is monitored via a reference element and a control signal returned via an opto-isolator to the control element of the high voltage switching transistor. The  $\pm 15V$  dc rails are generated via separate secondary windings which are rectified, smoothed and stabilised by linear regulators. The SMPS operates over an input voltage range of 110V to 240V ac  $\pm 10\%$ , 50/60Hz. The auxiliary supply fuse FS1 provides protection of the high voltage elements.



**Figure 3- 12 591 Power Board 2 Quad (AH385851U003, U004)**

## Heatsink Cooling Fan Connections

When fitted, these fans are connected on the power board to FAN LIVE (F27), FAN NEUTRAL (F24) and FAN COMMON (F23) as described below:

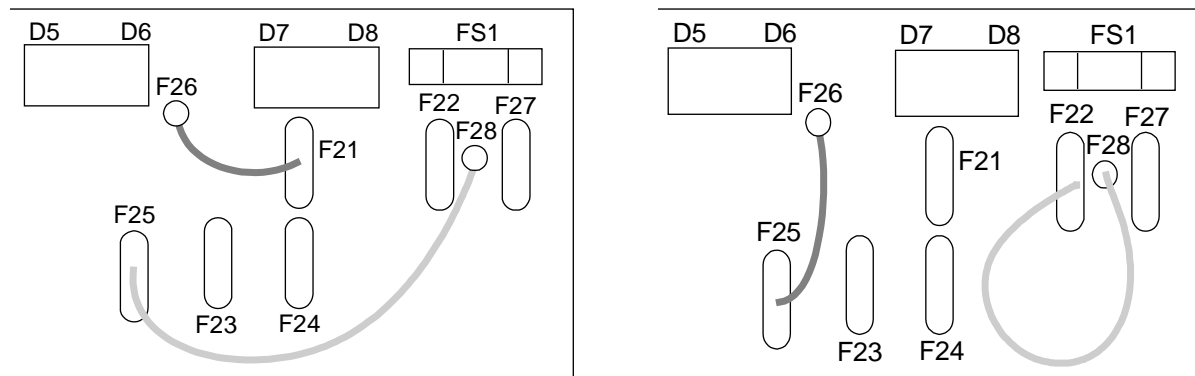
- A single fan must be matched to the auxiliary supply and connected to F27 and F24.
- Two fans using a 110/115V auxiliary supply must be connected in parallel to F27 and F24.
- Two fans using a 220/240V auxiliary supply must be connected in series to F27 and F24 using F23 as the centre point.

## Contactors Supply

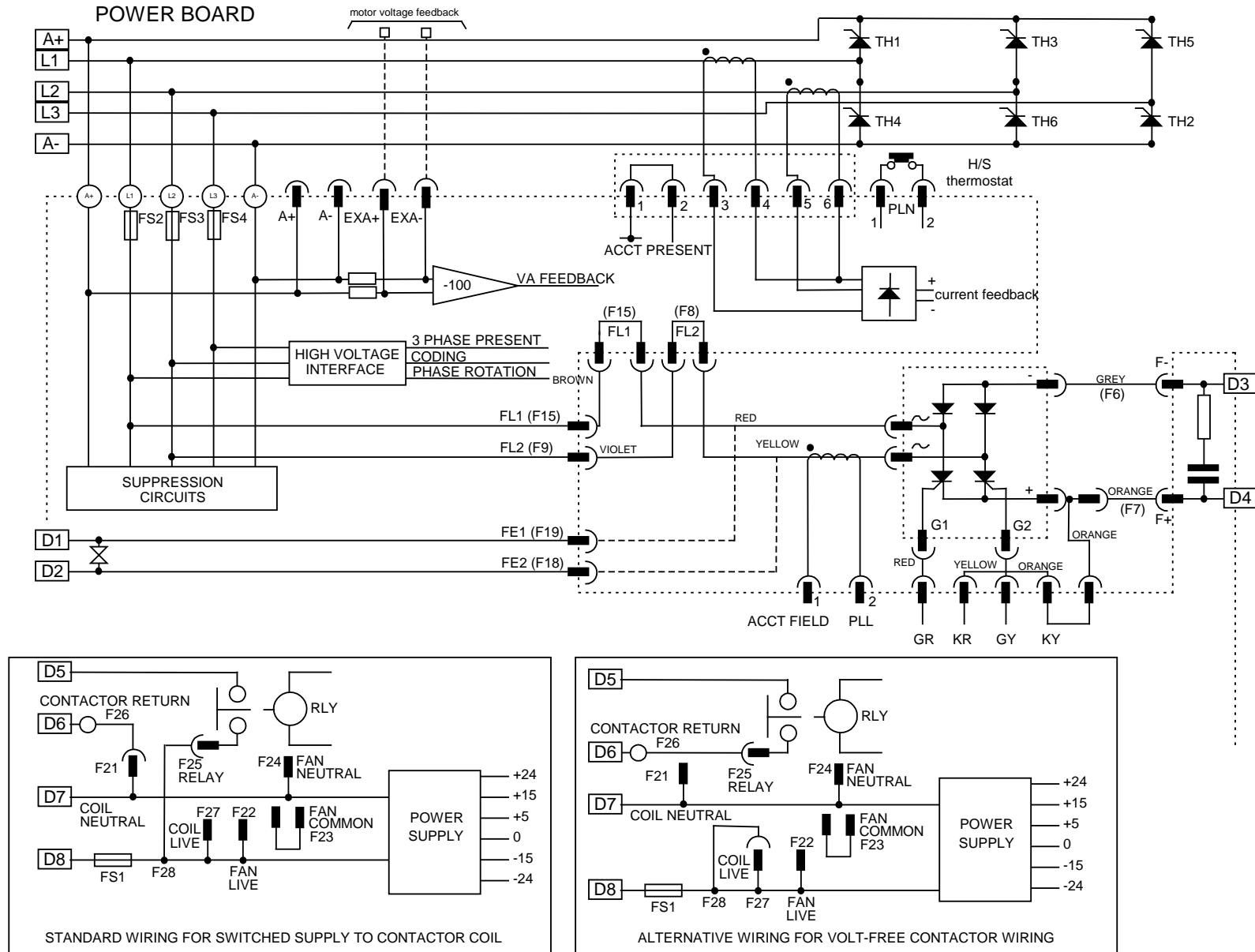
The controller requires an ac or dc power contactor in series with the main power path to ensure correct power-up sequencing. This contactor is directly initiated by the Microcontroller via an isolating relay which drives the contactor coil with the same voltage as that of the auxiliary supply.

This is achieved by the brown wire connection from COIL LIVE (F28) to RELAY (F25) and the blue wire connection from COIL NEUTRAL (F21) to CONTACTOR RETURN (F26).

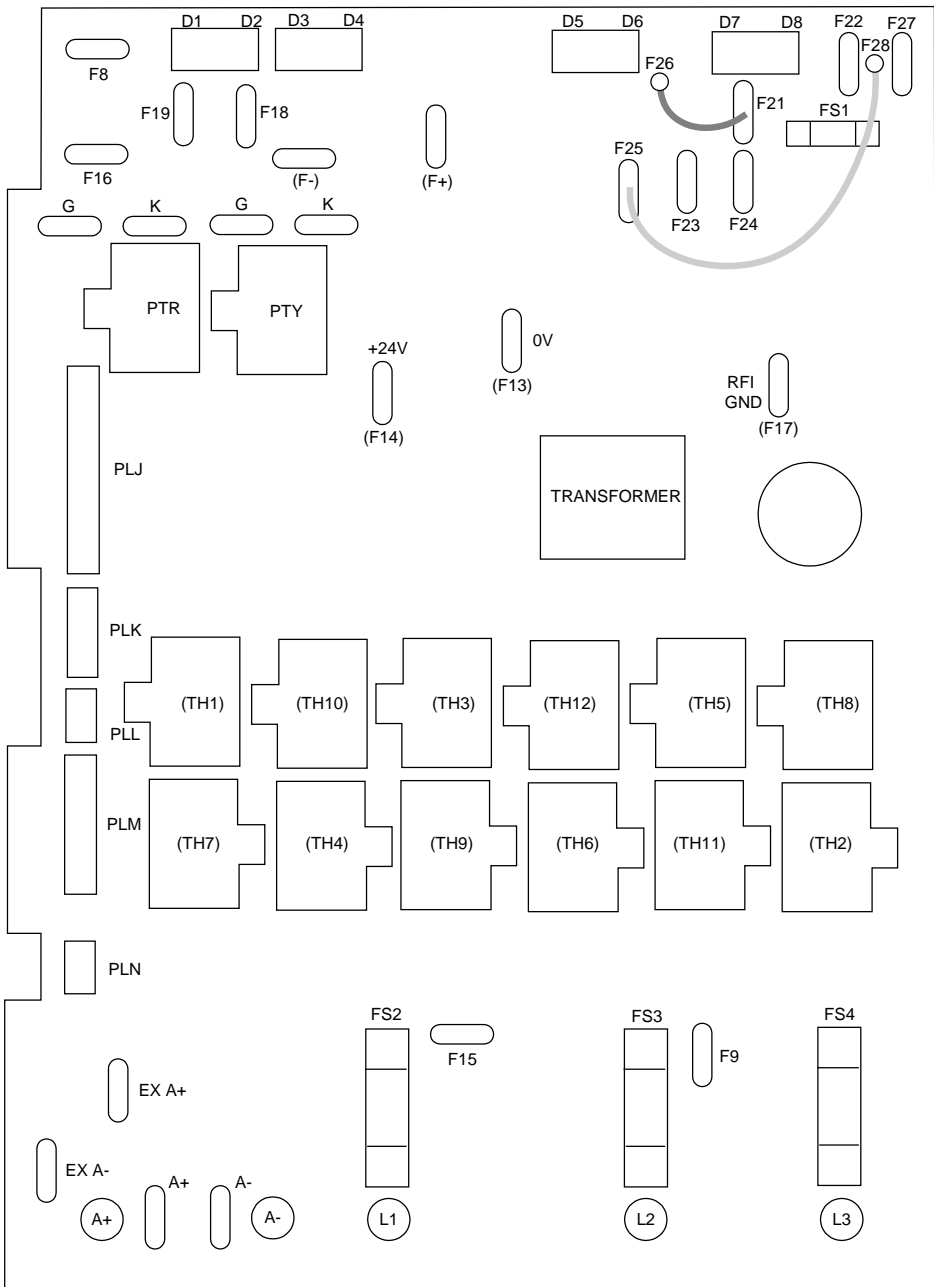
However, if an alternative supply for the contactor coil is required move the brown wire from F25 to F22, and move the blue wire from F21 to F25. The external coil supply can now be switched using a volt-free contact between terminals D5 and D6.



### 3-32 Installing the Drive



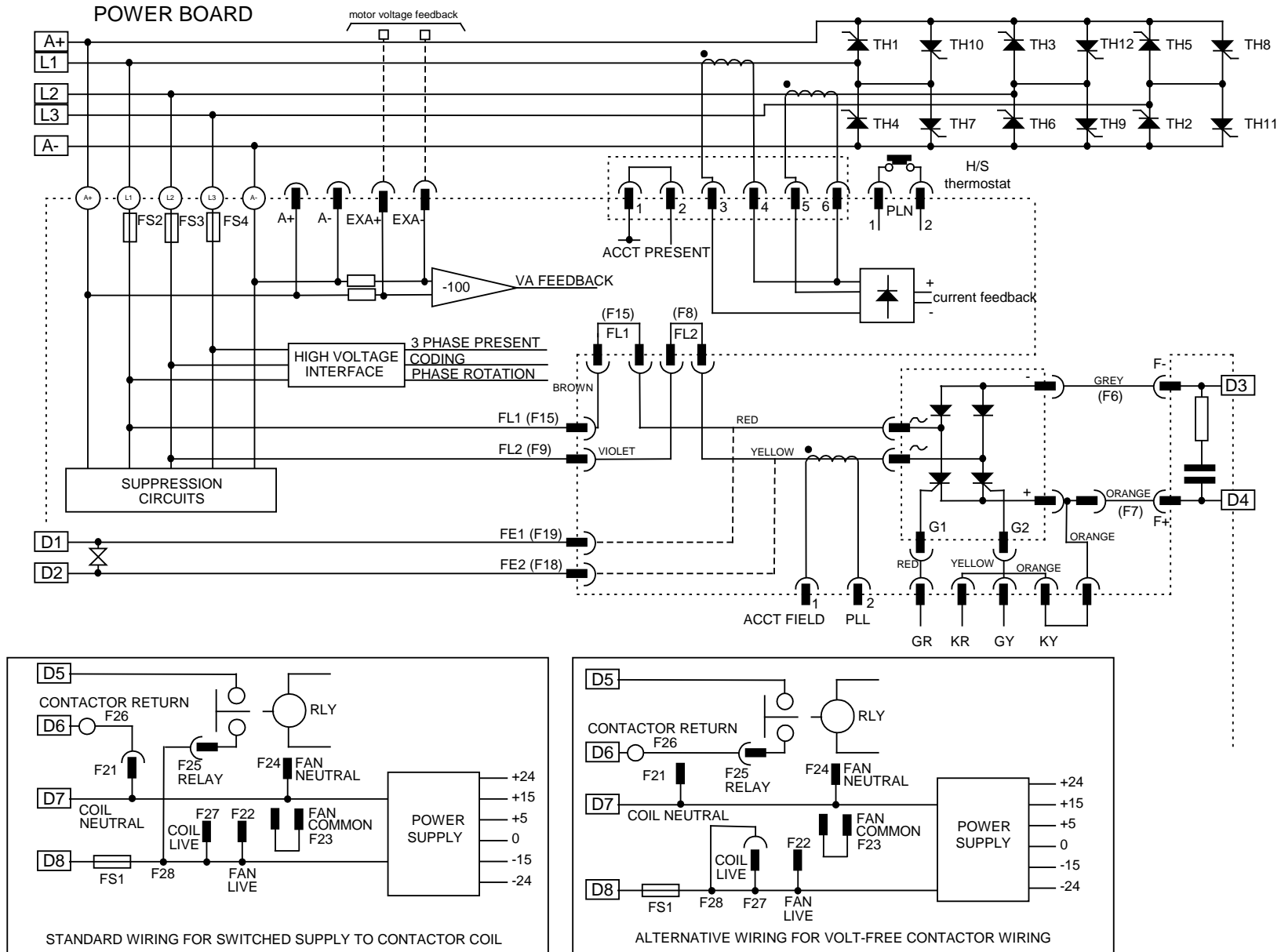
**Figure 3- 13 2 Quad Power Circuit - using AH385851U003, U004 (Frame 3)**



**Figure 3- 14 590 Power Board  
4 Quad  
(AH385851U002, U005) - (Frame 3)**



### 3-34 Installing the Drive

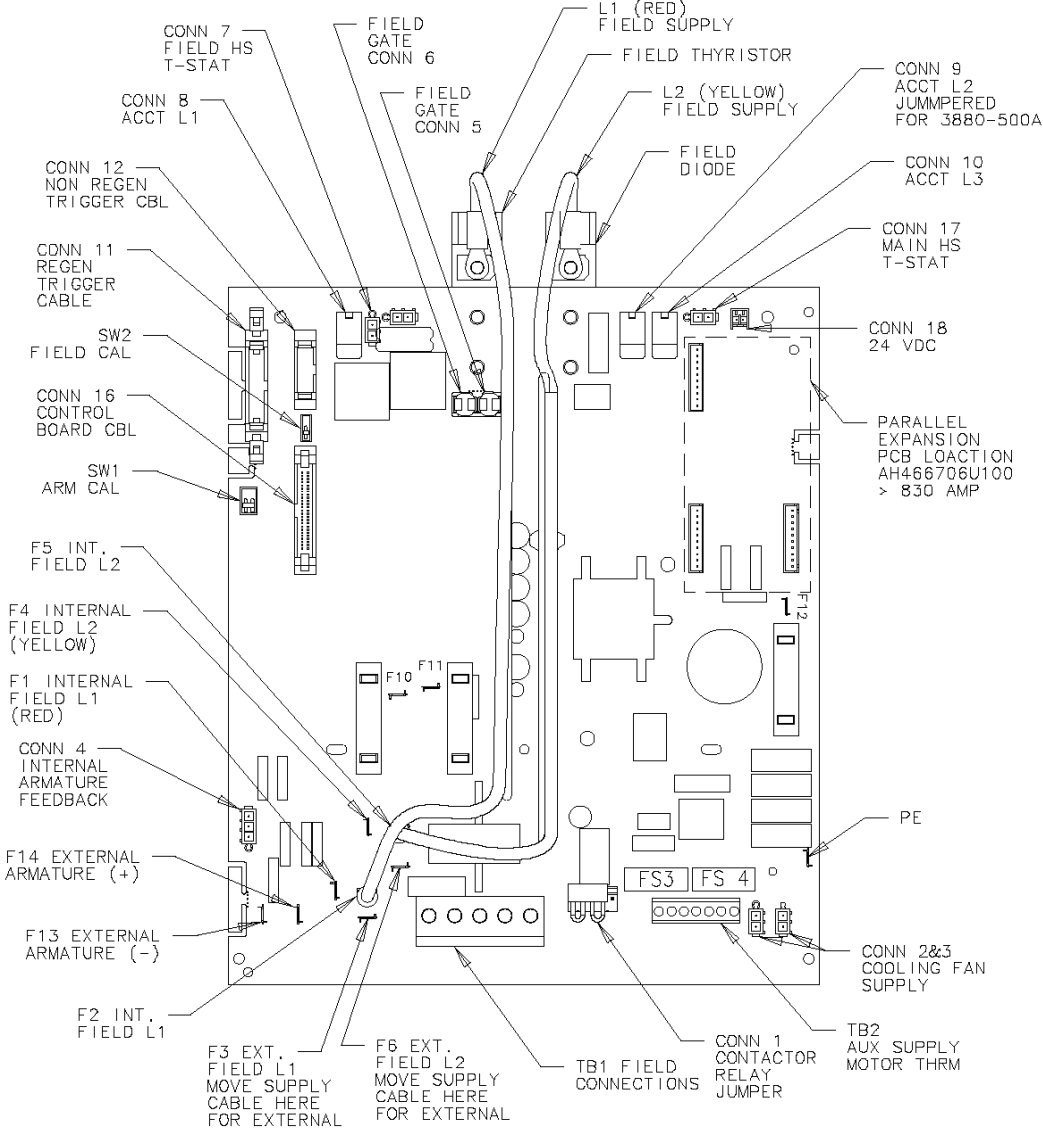


**Figure 3- 15 4 Quad Power Circuit - using AH385851U002, U005 (Frame 3)**

# AH466701U001, U002, U003 (Frames 4 & 5)

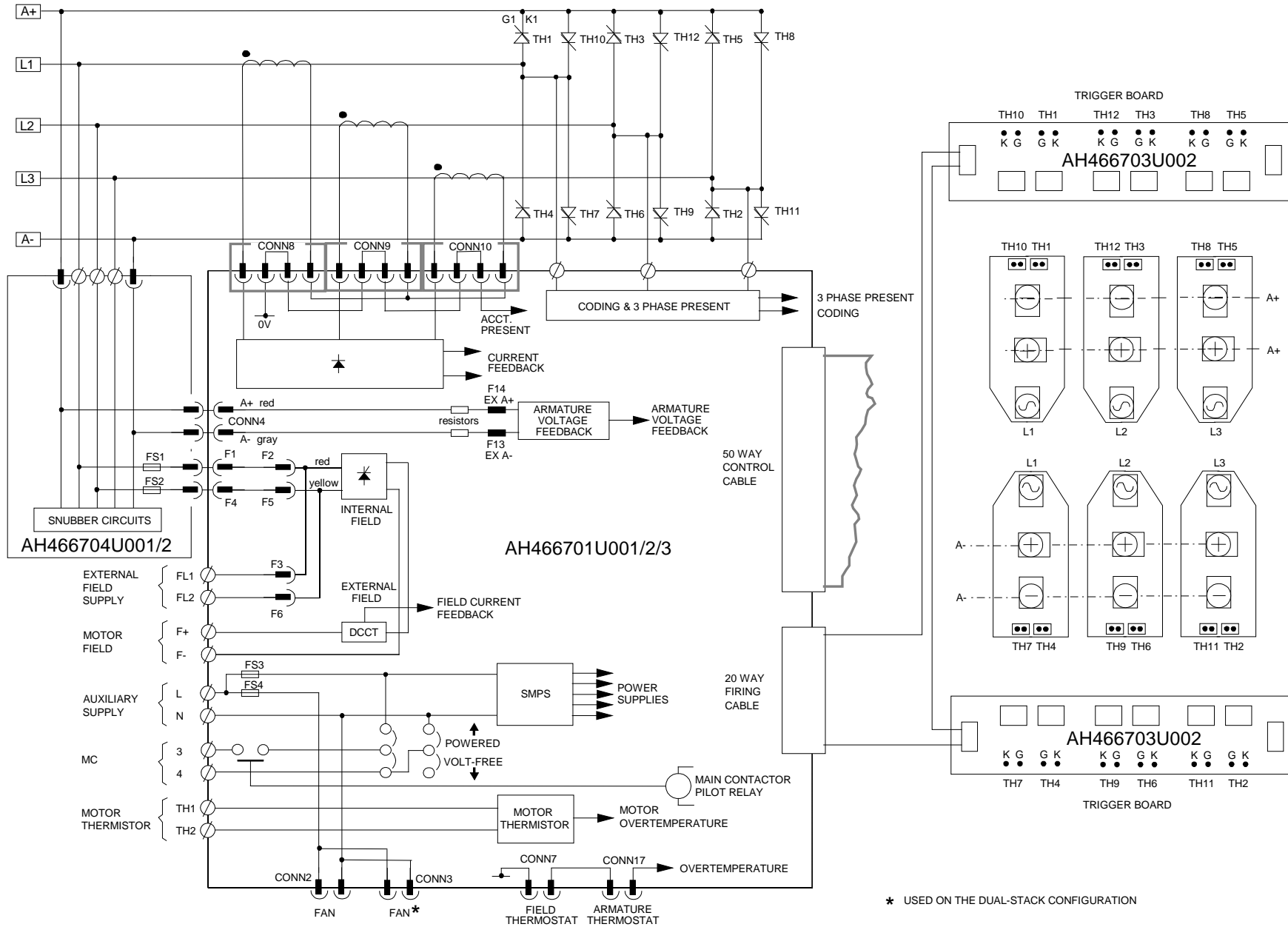
**590+ 4 Quad and 591+ 2 Quad;  
Low, Medium and High Volt**

Power supplies for the controller are generated from the single phase auxiliary supply via a Switched Mode Power Supply. The incoming supply is directly rectified to provide a high voltage dc power rail. A high voltage transistor switches this rail on to the primary of a high frequency transformer, the output of which is rectified and smoothed to provide the dc power supply rails. The +15V dc rail is monitored via a reference element and a control signal returned via an opto-isolator to the control element of the high voltage switching transistor. The other dc rails (-15V & +24V dc) are generated via separate secondary windings which are rectified and smoothed, with a separate SMPS element providing a regulated +5V dc rail. The SMPS operates over an input voltage range of 110V to 240V ac  $\pm 10\%$ , 50/60Hz.



**Figure 3- 16  
590+/591+ Power Board**

### 3-36 Installing the Drive



\* USED ON THE DUAL-STACK CONFIGURATION

**Figure 3- 17 4 Quad Power Circuit – Frame 4 & 5 Units using AH466701**

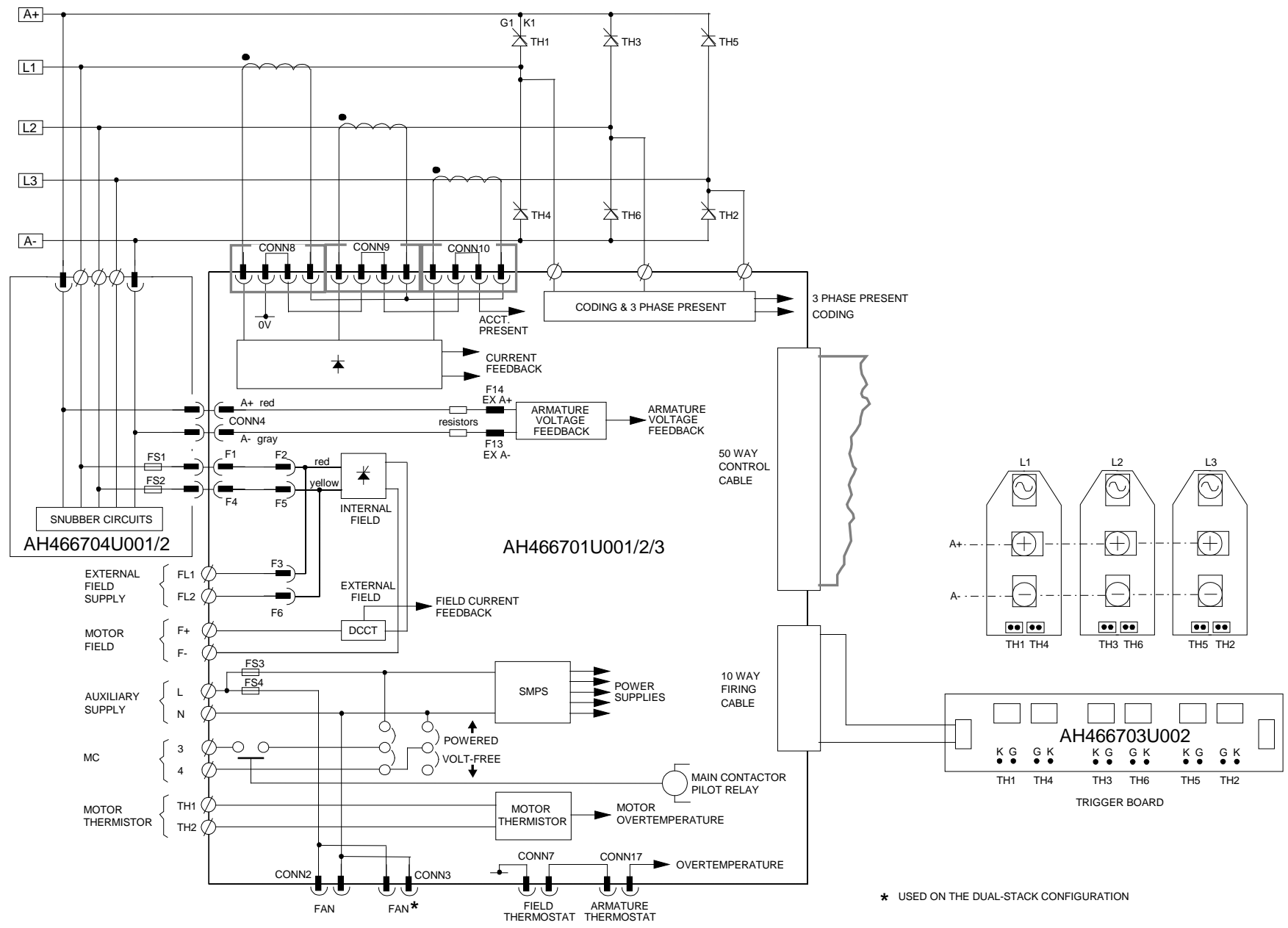
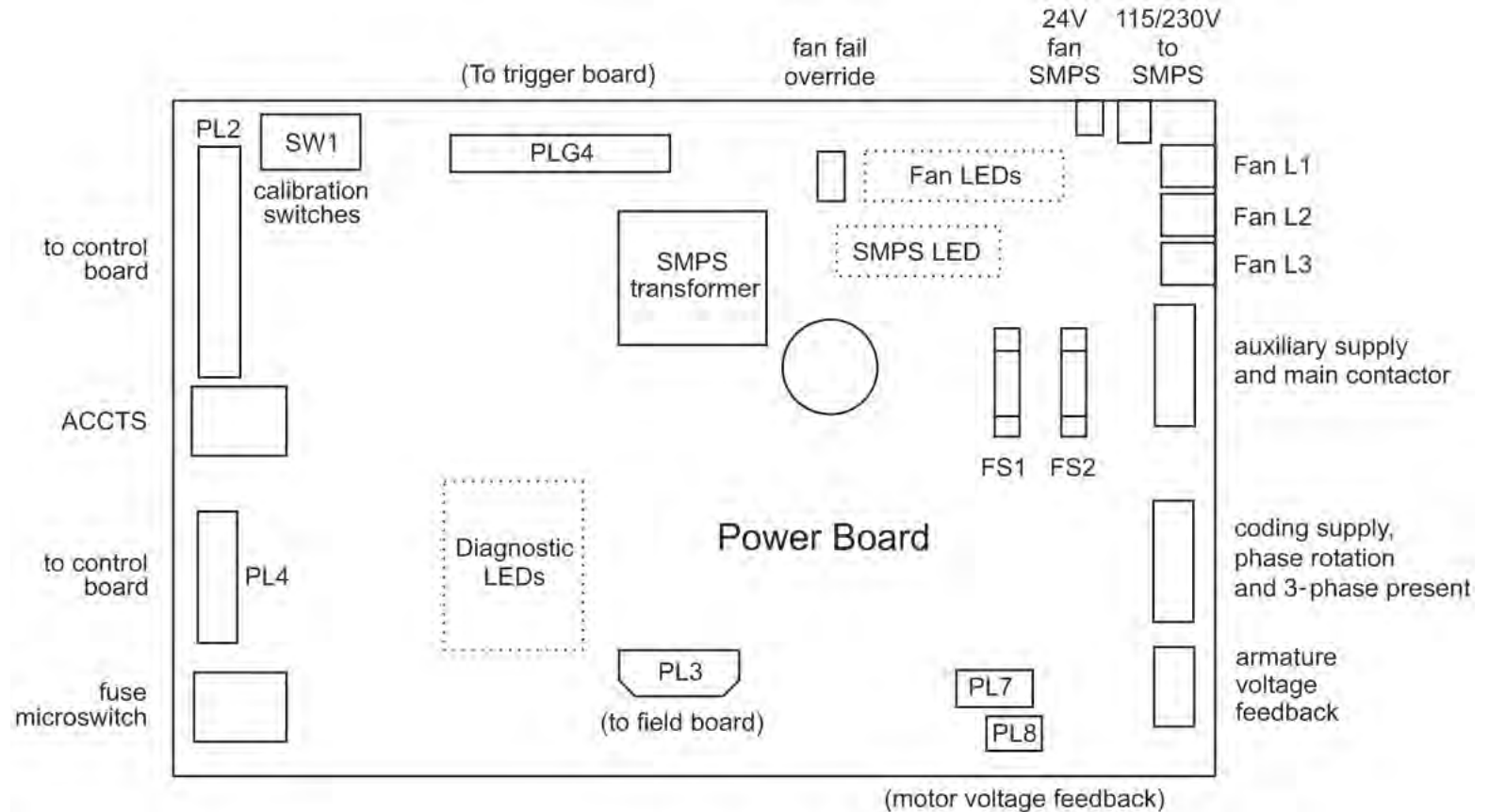


Figure 3- 18 2 Quad Power Circuit – Frame 4 & 5 Units using AH466701

## 3-38 Installing the Drive

### AH469419 (Frame 6)

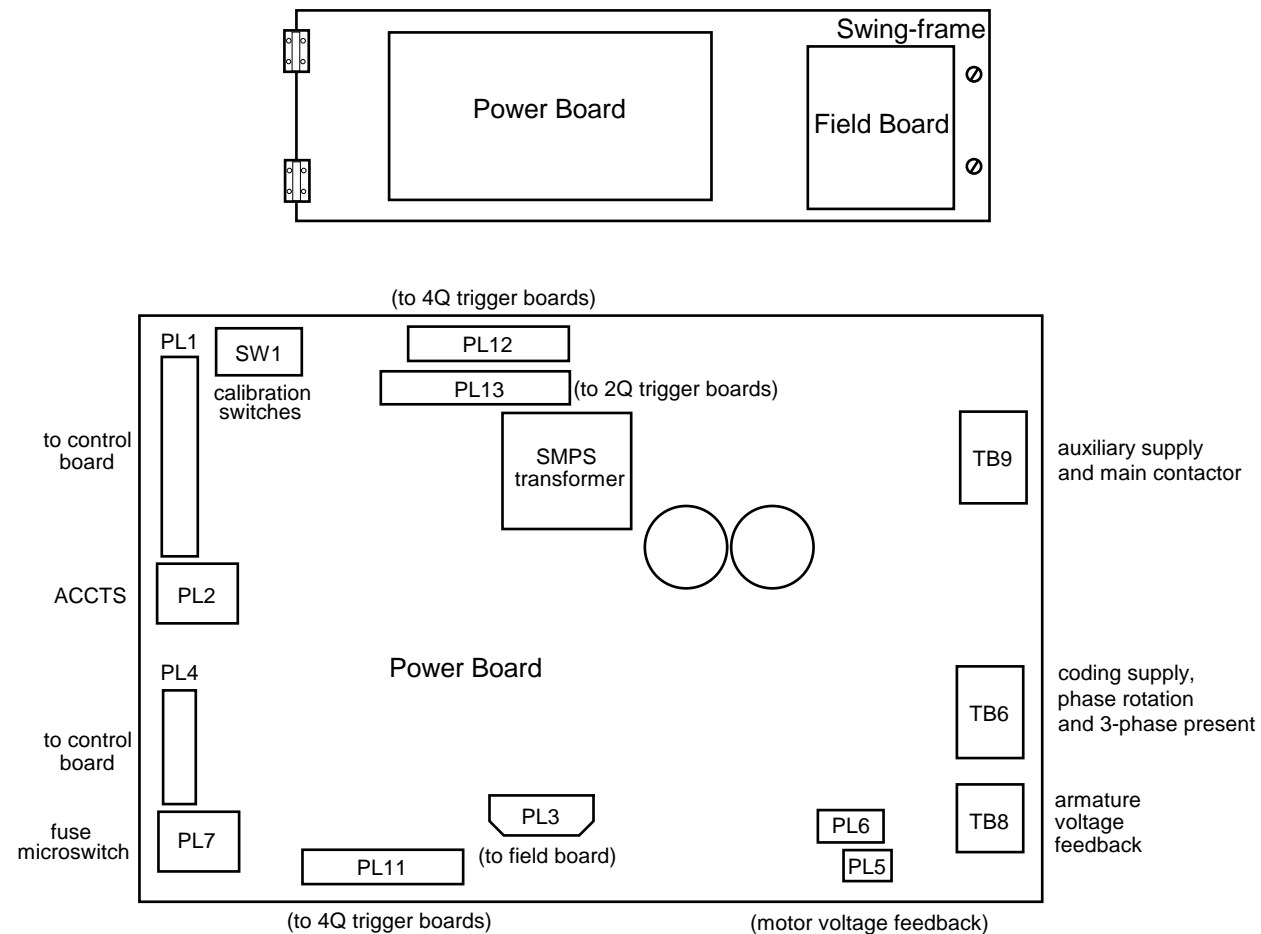
Power supplies for the controller are generated from the single phase auxiliary supply via a Switched Mode Power Supply. The incoming supply is directly rectified to provide a high voltage dc power rail. A high voltage transistor switches this rail onto the primary of a high frequency transformer, the output of which is rectified and smoothed to provide the dc power supply rails. The 5V dc rail is monitored via a reference element and a control signal returned via an opto-isolator to the control element of the high voltage switching transistor. The other dc rails (-15V & +24V dc) are generated via separate secondary windings which are rectified and smoothed, with individual linear regulators providing  $\pm 15V$  dc rail. The SMPS operates over an input voltage range of 115V to 230V ac  $\pm 10\%$ , 50/60Hz.



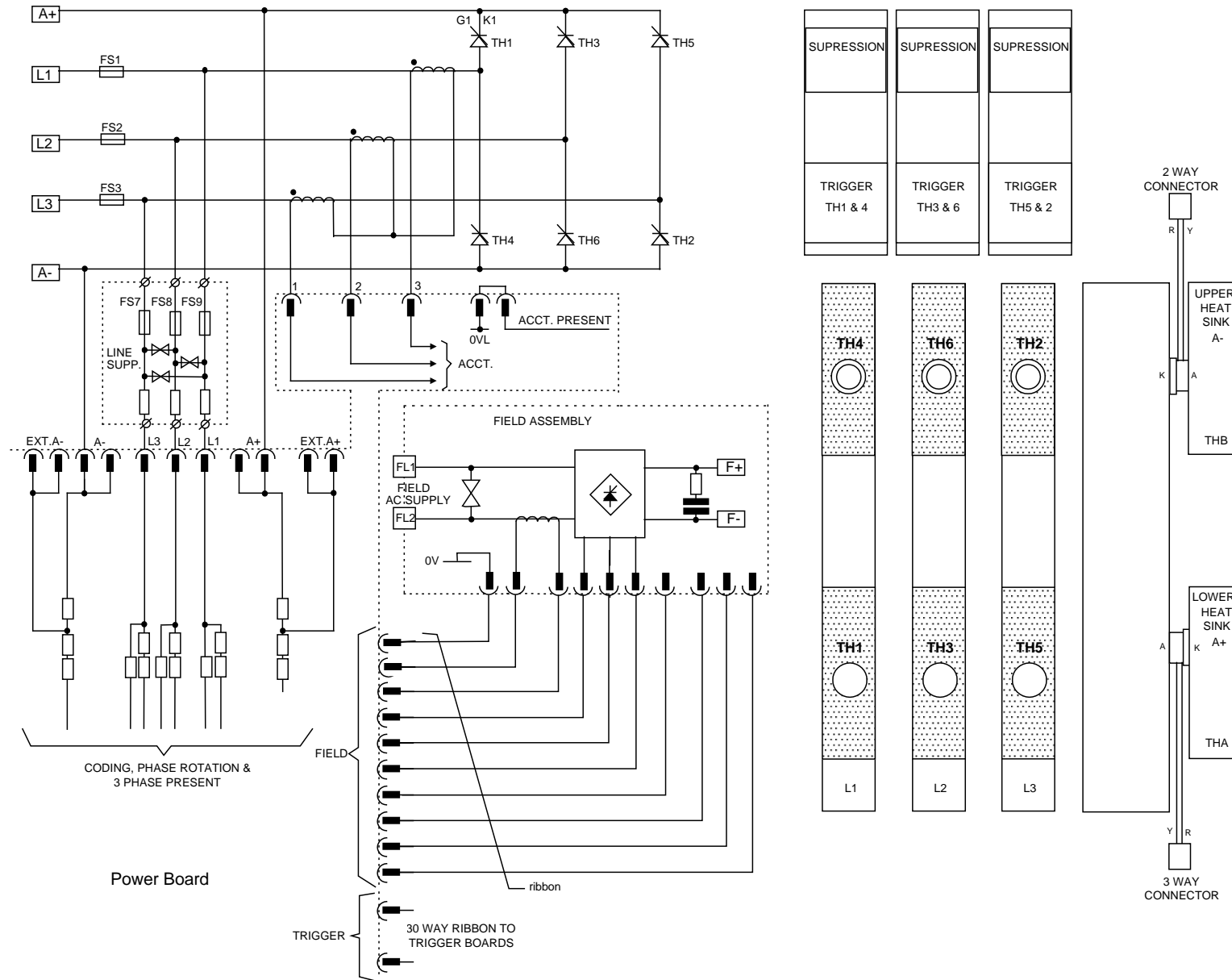
## AH466001U001, U101 (Frame 7)

(590+ - 4 Quad and 591+ - 2 Quad; Low and High Volt)

Power supplies for the controller are generated from the single phase auxiliary supply via a Switched Mode Power Supply. The incoming supply is directly rectified to provide a high voltage dc power rail. A high voltage transistor switches this rail on to the primary of a high frequency transformer, the output of which is rectified and smoothed to provide the dc power supply rails. The 5V dc rail is monitored via a reference element and a control signal returned via an opto-isolator to the control element of the high voltage switching transistor. The other dc rails (-15V & +24V dc) are generated via separate secondary windings which are rectified and smoothed, with individual linear regulators providing  $\pm 15V$  dc rail. The SMPS operates over an input voltage range of 110V to 240V ac  $\pm 10\%$ , 50/60Hz.



# 3-40 Installing the Drive



**Figure 3- 19 2 Quad Power Circuit – Frame 6 & Frame 7 Units using AH466001U001**

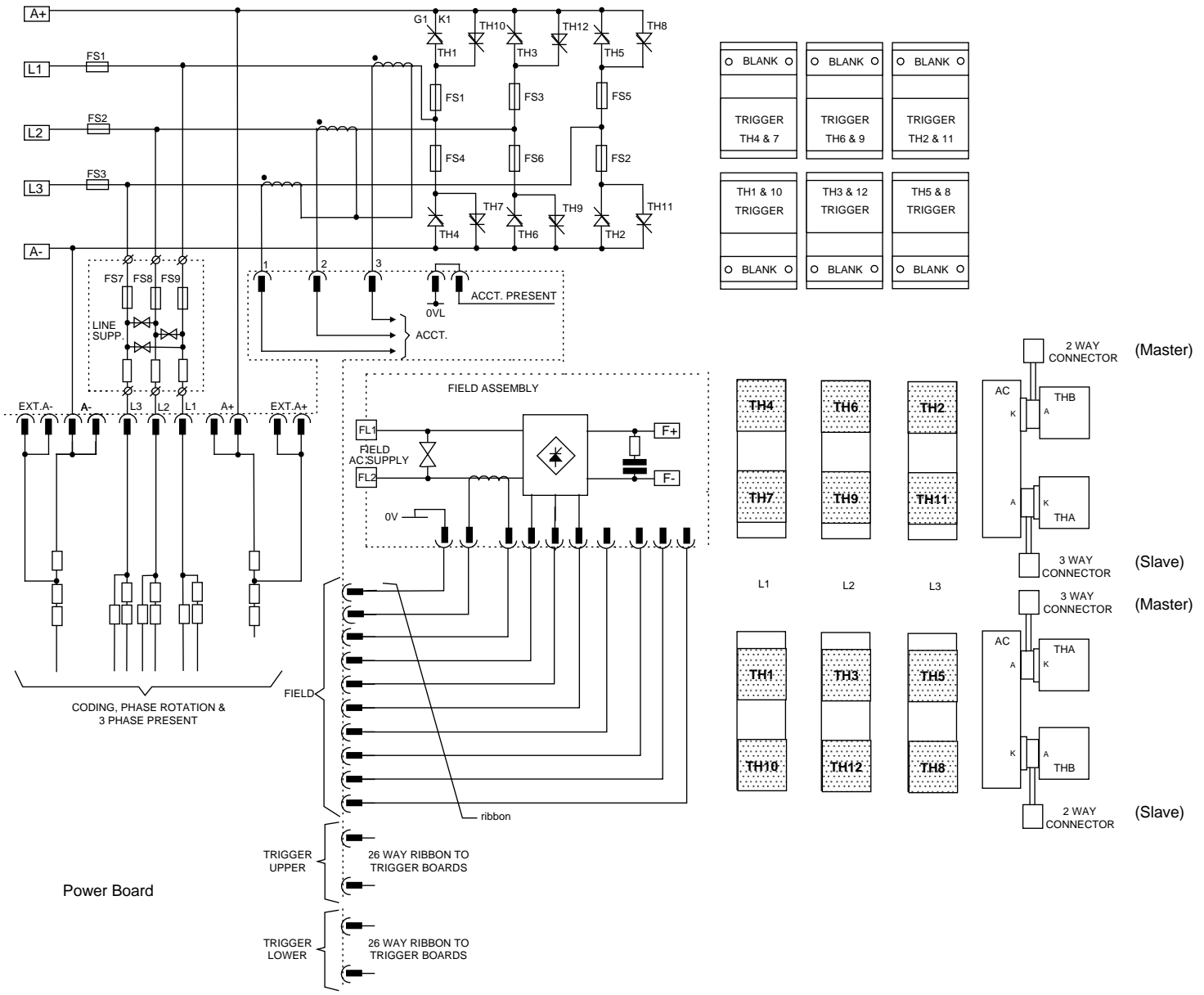


Figure 3- 20 4 Quad Power Circuit – Frame 6 & Frame 7 Units using AH466001U001



# Optional Equipment

## Remote Mounting the Keypad

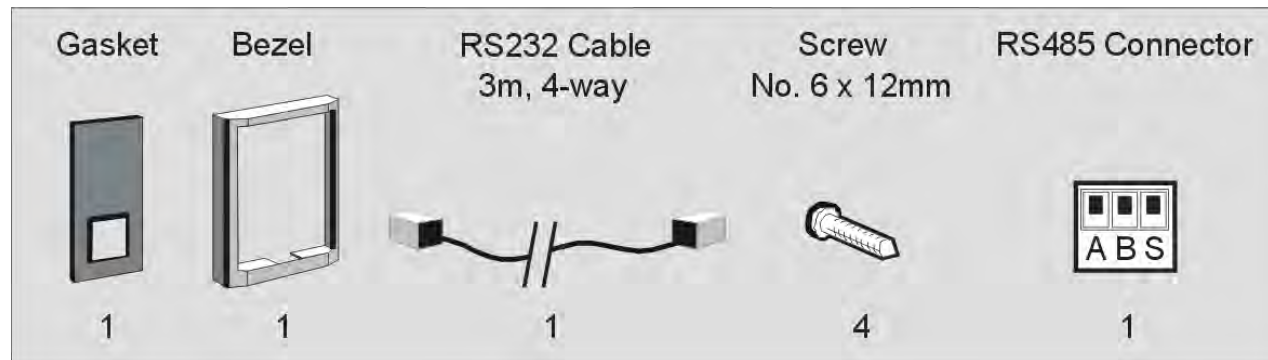
The 6052 Mounting Kit is required to remote-mount a 6901 or 6911 Keypad. An enclosure rating of IP54 is achieved for the remote Keypad when correctly mounted using the 6052 Mounting Kit.

You can also replace a Keypad for a PC running DSELite (or other suitable PC programming tool) in all of the options above. Refer to Appendix A: "Serial Communications".

### 6052 Mounting Kit Parts for the Remote Keypad

#### Tools Required

No. 2 Posidrive screwdriver.



An actual size template is provided with the Keypad/6052 Mounting Kit.

**Note:** Insert the Blank Cover (part number LA389836U001). It replaces the Keypad on the front of the drive, and provides "Health" and "Run" indications.

### Assembly Procedure

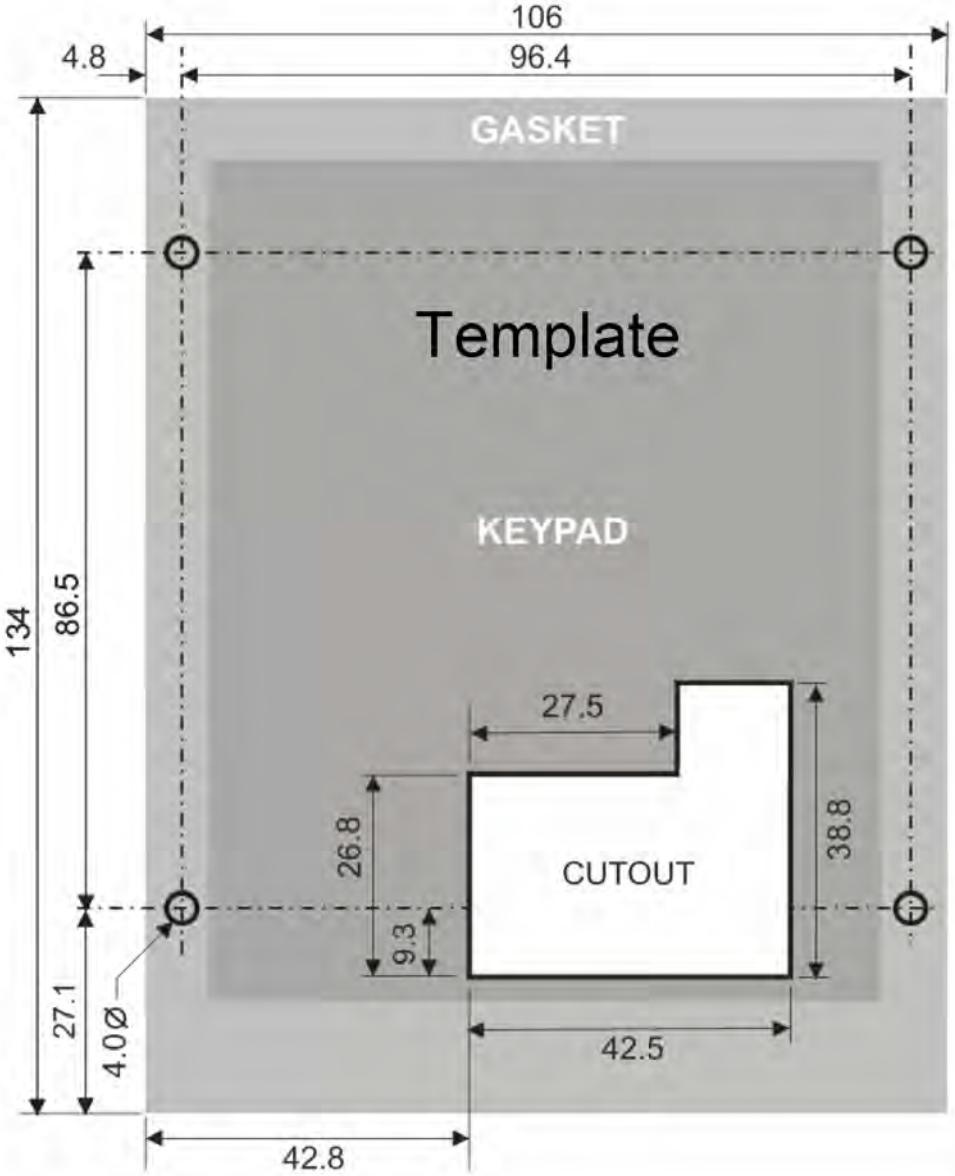
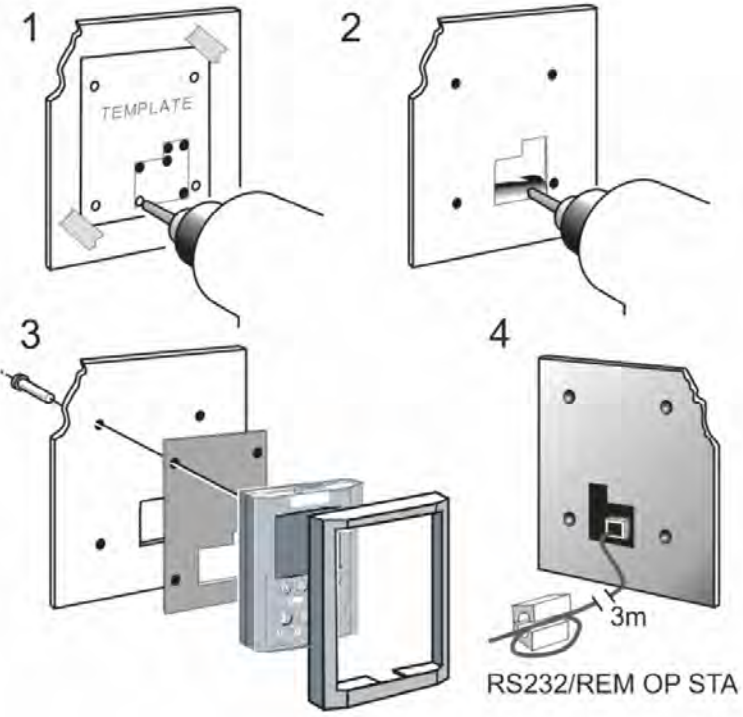


Figure 3-21 Mounting Dimensions for the Remote-Mounted Keypad

---

### Dynamic Braking Option

The DC590+ DRV Frames 1 and 2 are equipped with an AC (line-side) contactor. For dynamic braking applications, you will need a braking resistor and this kit to connect the resistor across the motor terminals. This combination, in accordance with NEMA ICS 3-302.62, will provide 150% instantaneous braking torque from base speed for each power range, with 2 times motor inertia and 3 stops per hour.

Please contact Parker SSD Drives for more information.

---

### Blower Motor Protector Option

This option uses a manual motor circuit controller to provide motor overload and branch circuit protection for a single or three phase AC blower motor. The starter assembly is fully wired and ready for site installation. This option offers:

- Branch circuit protection
- Instantaneous magnetic short circuit protection
- Thermal overload protection, Class 10, with adjustable trip current settings
- Start/Stop/Reset switching with “tripped” pushbutton indication
- Normally open auxiliary contact wired into the drive logic to indicate “Motor Overtemperature” trip

Please contact Parker SSD Drives for more information.

---

### Control Transformer Option (factory-fitted)

The three taps on the primary are selectable to set the correct input voltage of either 220V, 400V or 460V. The transformer has a single fuse in the secondary. Only applicable for Frames 1 & 2 with the “—CX” option.

Please contact Parker SSD Drives for more information.

## Speed Feedback Options

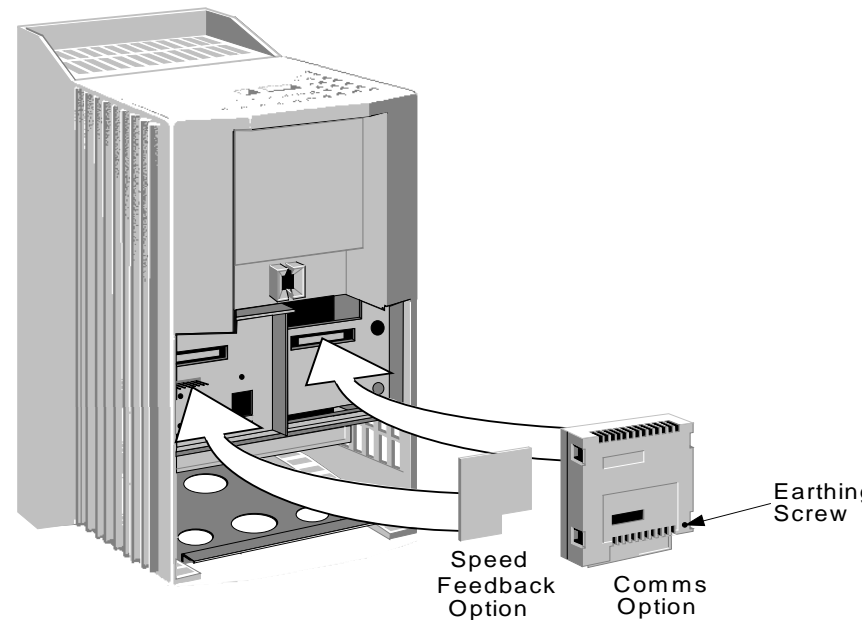
The DC590+ DRV Digital drive accepts the following types of speed feedback signals:

- armature voltage feedback ( see below)
- analog AC or DC tachometer generator feedback
- wire-ended electrical encoder feedback
- plastic (5701) or glass (5901) fiber optic Microtach encoder feedback.

**Armature Voltage Feedback** (default), does not require a feedback device, external isolator or any external connections.

This effectively provides an open-loop system. It equates the speed of the motor to voltage, but without compensating for the motor resistance within the system. Applying the parameter IR COMPENSATION can improve this. However, although the performance is adequate for some applications, another form of speed feedback should be used where accurate speed control is required.

**NOTE** The speed loop is set-up for armature voltage by the **SPEED FBK SELECT** parameter in the **SPEED LOOP** function block. Select **ARM VOLTS FBK** for this parameter.



**NOTE** All other types of speed feedback require a separately ordered, controller-mounted, option board and external feedback device.

## 3-46 Installing the Drive

### Feedback Receiver Board Installation

Each speed feedback board mounts on the lower left portion of the control board as shown above. Terminal assignments for each option board are listed in Appendix E and in the documentation shipped with the boards.

To install the receiver board on the drive control board:

1. Remove the packaging from the feedback receiver board.

---

### Caution

Caution Encoder and Microtach receiver boards contain electrostatic discharge (ESD) sensitive parts. Observe static control precautions when handling and installing the board.

---

2. Align the 10-pin connector on the option board with the controller pins on the lower left of the control board.
3. Carefully push the receiver board onto the pins taking care not to bend the pins. All four white support standoffs should engage the control board. If installing a switchable analog tachometer generator calibration board, be sure to connect the jumper on the right side of the board to its mating jack.
4. Refer to the Technical Manual supplied with the Option for specific instructions.

### Analog Tachometer Generators (G1, G2, G3, G4)

The switchable tachometer calibration board option supports both AC and DC analog tachometer generators with a calibration range of 10 to 209 volts. The calibration resistors and the board switch settings coarsely scale the speed feedback signal. Adjust parameters in the MMI for fine-tuning (refer to Chapter 4).

The signal cable for the analog tachometer generator *must* be shielded over its entire length.

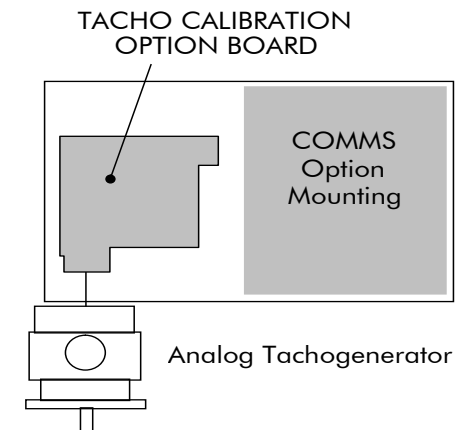
**NOTE** Ground the tachometer generator shield at the drive end only to avoid ground loops.

Terminals G1 & G2 are for AC tacho connections.

Terminals G3 & G4 are for DC tacho connections.

The speed loop is set-up for an analog tacho by the SPEED FBK SELECT parameter in the SPEED LOOP function block. Select ANALOG TACH for this parameter.

**NOTE** If an AC tachogenerator is used, the output is rectified to produce the dc feedback to the speed loop. Consequently, the drive can only be used with a positive setpoint.

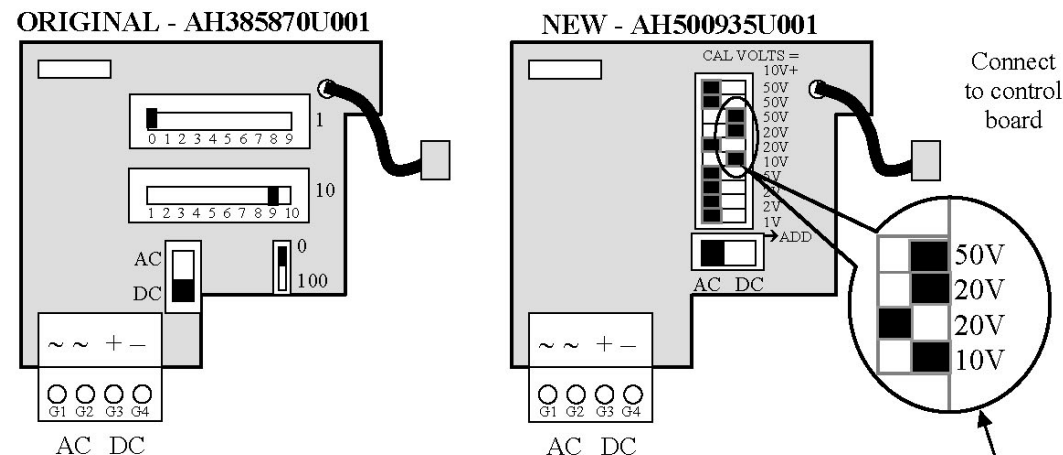


**Analog Tacho Calibration Option Board****WARNING****Do not fit this Option Board with the drive powered-up**

This product may be fitted with a new version of the Analog Tacho Calibration Option Board.

**ORIGINAL** The original option has Part Number AH385870U001 and is configured by setting its two 10-position slide switches and two 2-position slide switches. Refer to Product Manual Chapter 4: “Selecting Speed Feedback” for further information on using this original option.

**NEW** The new option has Part Number AH500935U001 and is mounted in the same manner as the original. The connecting link wire to the control board is still required and must be connected for operation. It is configured by setting its single 10-way switch and single 2-position switch.

**Calibration of the new AH500935U001 version**

On this new version of the option the full-speed tachogenerator voltage is configured by adding together the values from any number of the individual selection switches (on the 10-way switch).

$$\text{CALIBRATED FULL-SPEED VOLTAGE} = 10\text{V} + \text{SUM OF SWITCHES SELECTED}$$

**NOTE: Individual switch values will be included if the switch is set to the right.**

In the example AH500935U001 shown above (with three switches selected): Calibrated full-speed voltage = 10V + (50V + 20V + 10V) = 90V

**IMPORTANT** The calibrated full-speed voltage is 10V greater than the sum of switch values selected.

## 3-48 Installing the Drive

This AH500935U001 board continues to support both AC and DC analog tachos with a calibration range of 10 to 200V.

- For AC tacho feedback, use terminals G1 & G2, with selector switch in the AC position (left). Calibrate the switches for  $\sqrt{2}$  x full-speed voltage required, i.e.  $\sqrt{2} \times 90V = 127V$ . This adjusts the r.m.s. value received from an AC tacho into the required peak value.
- For DC tacho feedback, use terminals G3 & G4, with selector switch in the DC position (right).

**NOTE** Do not set the calibration volts to greater than 200V, the max. terminal block rating.

### Wire-ended Electrical Encoders (E1, E2, E3, E4, E5, E6)

The wire-ended encoder can be connected to the drive via the Wire-Ended Encoder Option Board. This board provides terminals E1 to E6. Terminals E1 (0V) and E2 (+24V dc) are the return and supply respectively.

The drive can accept a standard, 4-channel, quadrature complimentary, wire-ended electrical encoder signal as speed feedback.

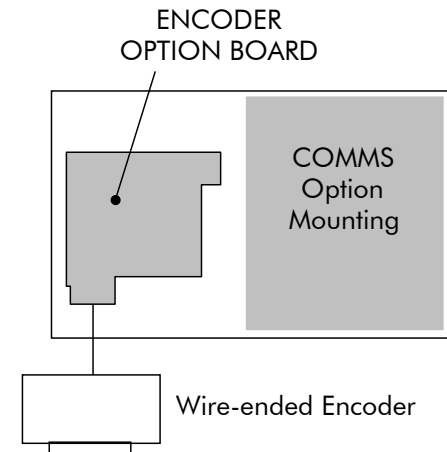
Four feedback boards are available, each having a different supply voltage rating. Complimentary line driver encoders are recommended.

When using a wire-ended electrical encoder as feedback, be sure to use three channel, twisted, shielded cable and to ground the shield at the drive end only. Belden 8777 cable is recommended.

The speed loop is set-up for the Encoder by the SPEED FBK SELECT parameter in the SPEED LOOP function block. Select ENCODER for this parameter.

The maximum allowable encoder frequency is 100kHz, thus with a standard 1000 lines per revolution encoder the motor speed cannot exceed 6000 rpm.

For specification and connection information refer to Parker SSD Drives or the Technical Manual supplied with the Encoder.



### Microtachs (F1, C1, C9)

A Microtach can be connected to provide speed feedback via the Microtach Option Board using the international standard “ST” fibre optic system. This board provides terminal F1. F1 is the fibre optic receiver input socket. Terminals C9 (+24V dc) and C1 (0V) are used to provide the supply and return respectively.

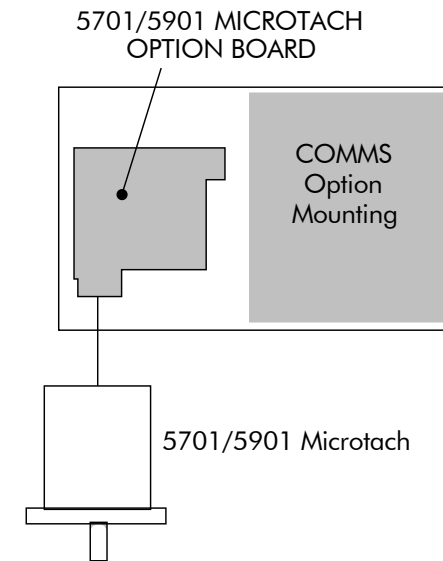
Fiber optic encoders (or Microtachs) come in either glass or plastic.

- While the glass Microtachs (5901) can transmit a feedback signal over a long range without a repeater, they require a special termination tool to properly cut and polish the glass fiber optic cable.
- The 5701 Microtach is used with plastic fiber optic cable, which needs only a set of pliers for termination. The signal range for plastic, however, is limited and may require a Microtach repeater. ½" diameter, composite, plastic, fiber optic cable is available. The cable includes two 16 AWG conductors with a plastic fiber optic conductor sheathed in a protective plastic coating. This cable is recommended when running plastic fiber optic cable within conduit.

Each type of Microtach requires its own receiver board and may be powered directly from the drive's +24 VDC supply.

The speed loop is set-up for the Microtach by the SPEED FBK SELECT parameter in the SPEED LOOP function block. Select ENCODER for this parameter.

The maximum Microtach frequency is 50kHz, thus with a standard 1000 lines per revolution Microtach the motor speed cannot exceed 3000 rpm.

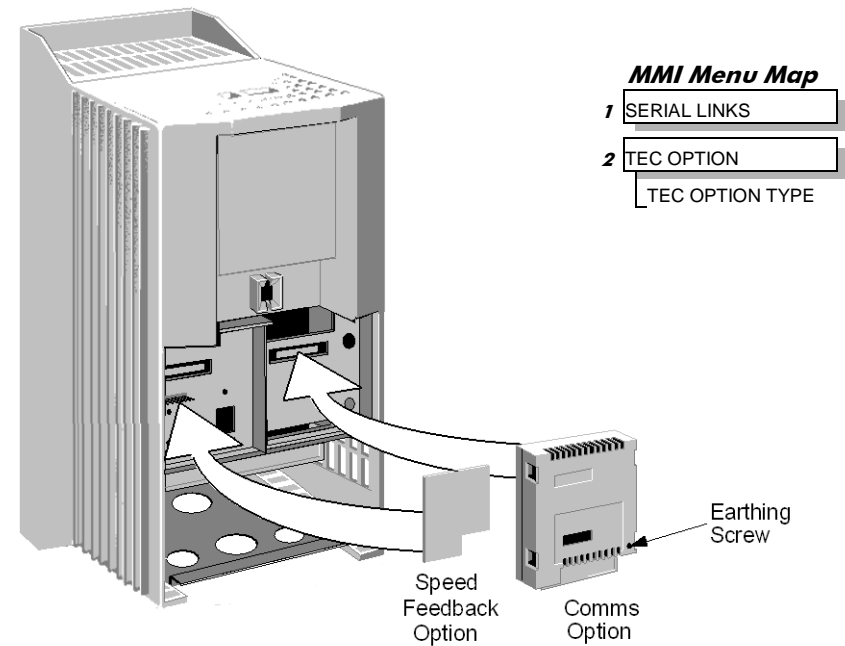




## Communications Technology Options

Various protocols are supported, each requiring a different Technology Box. The type of Technology Box fitted is selected in the TYPE parameter:

- RS485 (EI BINARY, EI ASCII or MODBUS RTU)
- PROFIBUS DP
- LINK
- DEVICENET
- CANOPEN
- LONWORKS

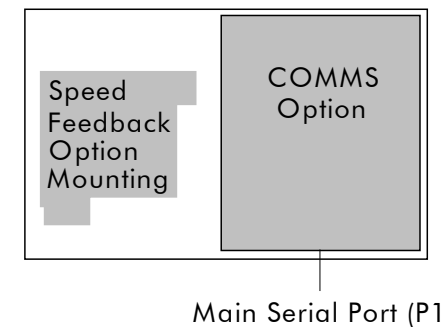


### COMMS Option Technology Box

The option allows the DC590+ DRV Drive to be controlled as part of a system.

The system can also comprise other Parker SSD Drives products such as the 605 and 584SV Inverters, or any other equipment using the same protocol.

**IMPORTANT :** The comms option should not be fitted or removed whilst the product is powered.



## Frame 6: Assembly and Installation



All units are available as a:

- 590+ : 4Q 3-phase, fully controlled, anti-parallel thyristor bridge configuration
- 591+ : 2Q 3-phase, fully controlled thyristor bridge configuration

The DC590+ Frame 6 is a high power DC drive and is supplied as a kit of parts ready for mounting onto the back panel of an enclosure. The drive can be arranged to have the AC input terminals either at the top or the bottom of the drive.

**NOTE** The phase assemblies must always be mounted with the fans at the bottom, however, the AC Supply Terminals can be moved to the top of the drive. Refer to page 3-55.

A kit contains three phase assemblies (each having the same rating), a control panel assembly, and fishplates. Fishplates are used to inter-connect the DC outputs of the three phase assemblies to produce a 6-pulse stack.

The control panel assembly mounts onto the front of the phase assemblies. The signals to-and-from the control panel assembly provide the operation of the drive.

## 3-52 Installing the Drive

Phase assemblies are available in three different ratings, at two different voltages, and in a two thyristor (2Q, non-regenerative) or four thyristor (4Q, regenerative) configuration.

When constructed, the drive is physically the same size for all ratings or configuration.

### Cubicle Details

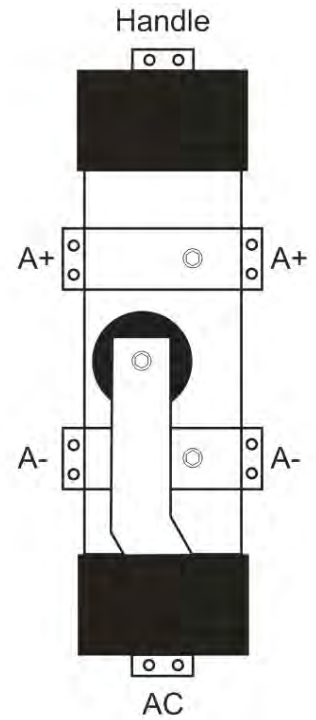
The drive must be mounted inside a cubicle that complies with the European safety standards VDE 0160 (1994)/EN50178 (1998) - it must require a tool for opening.

### Cooling

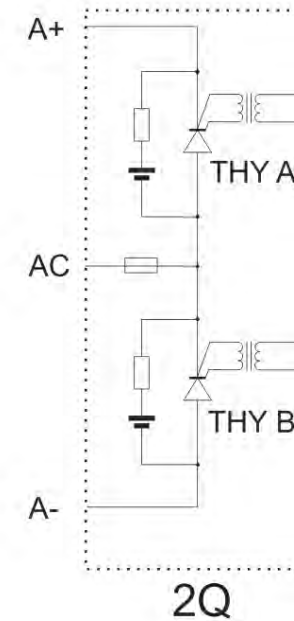
The assembled drive produces power (heat) losses of approximately 3 times the rated power output current. For example, a 2000A output current will produce a power loss of 6000W.

It is necessary to remove this heat by fitting fans in the roof of the enclosure. A suitable fan assembly is available from Parker SSD Drives, part number LA466038. The assembly contains two fans that can be connected in parallel or series to achieve 115Vac or 230Vac operation.

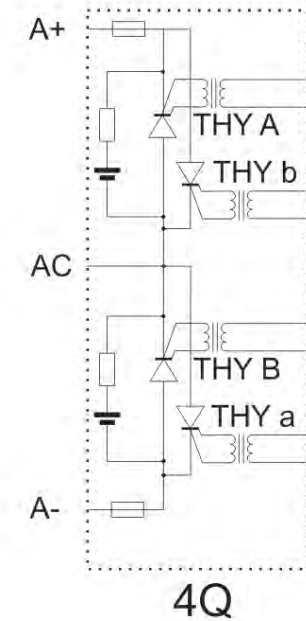
Fan Rating : 115V ac 50Hz, 1.67A, 177W, 2750 rpm, motor run capacitor 18 $\mu$ F.



A Phase Assembly



2Q

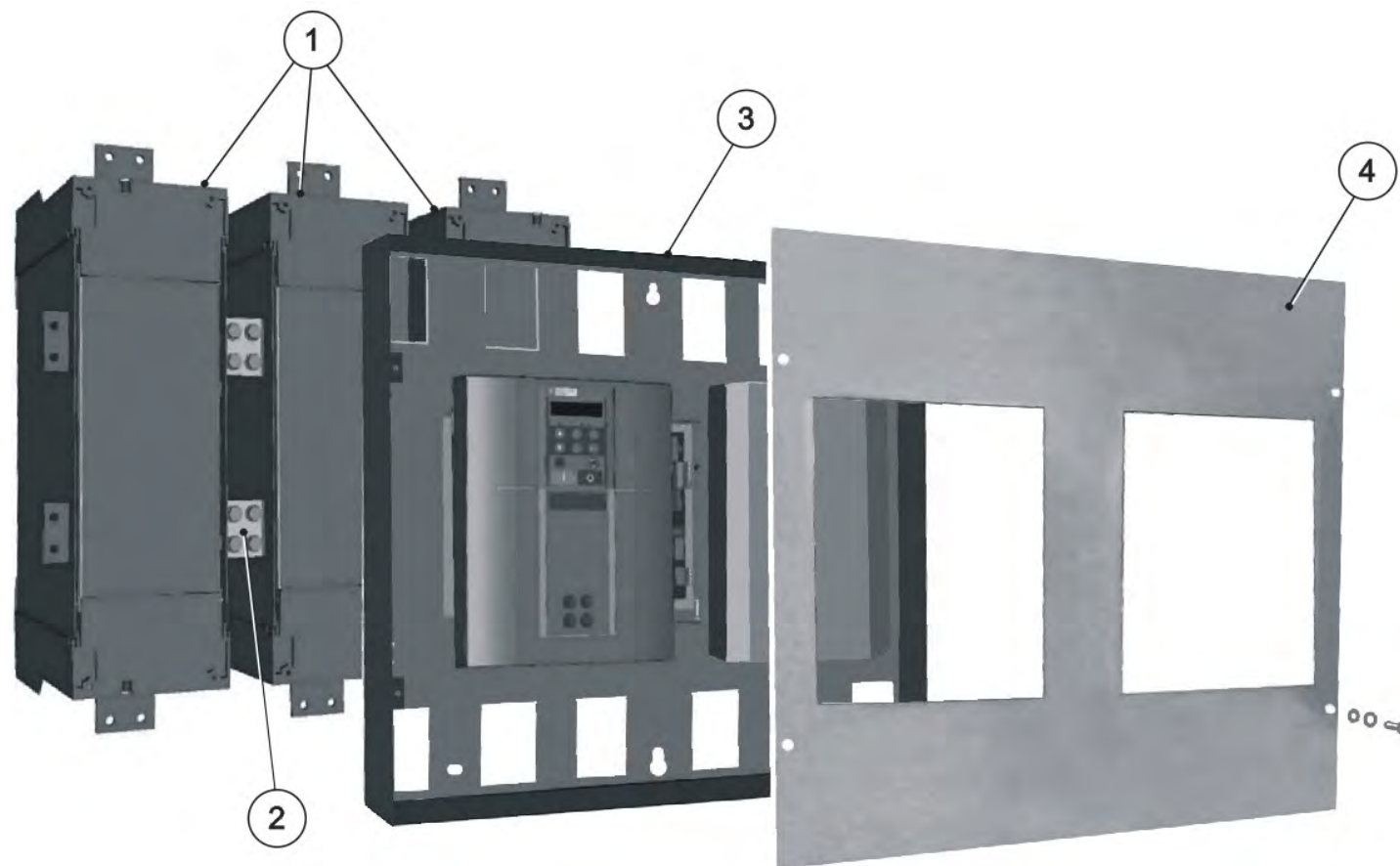


4Q

## Assembly

### Caution

Use proper lifting techniques when lifting and moving the unit.



- |                                 |                          |
|---------------------------------|--------------------------|
| 1 Phase assemblies - L1, L2, L3 | 3 Control Panel Assembly |
| 2 Fishplate                     | 4 Front Cover            |

## 3-54 Installing the Drive

The drive is assembled in the following order:

1. Mount the phase assemblies onto the backplate
2. Inter-connect the phase assemblies using the fishplates
3. Secure the control panel assembly onto the phase assemblies
4. Connect all signal cables and ribbons
5. Fit the front cover
6. Connect the plugs for the control wiring, auxiliary supply and field connections

To prepare for installation:

1. Remove the push-fit control terminals (A) from the control panel assembly.
2. Unscrew and remove the Power Terminals (B).
3. Remove the four screws and washers (C) securing the front cover to the control panel assembly.
4. Remove the front cover (D) from the control panel assembly.

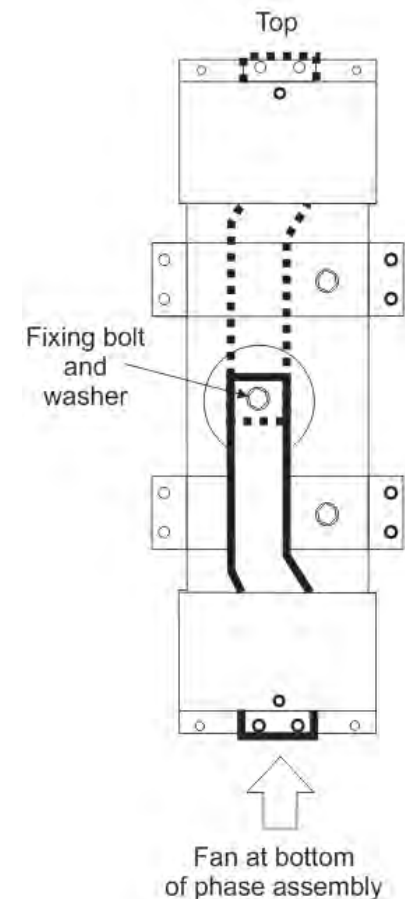
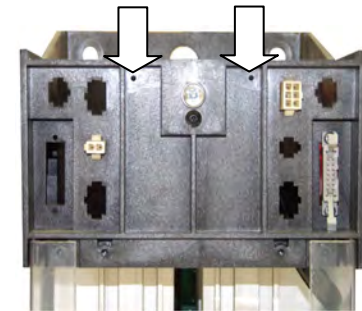


## Moving the AC Supply Terminals

The AC supply terminals - L1, L2 & L3 - can be made available at the top or bottom of the drive. The factory-delivered drive has the AC terminals in the lower position.

It only takes a few minutes to rotate the AC terminals to the upper position.

1. Remove the fixings that secure the Phase Assembly front cover.
2. Remove the two screws on the front of the phase assembly moulding that secure the handle in place. The handle is located at the top of the phase assembly. It looks like another AC terminal but it is electrically isolated. It is there to assist in handling the phase assembly and is used when securing the stabilising bracket. Refer to "Offering-Up the Phase Assemblies", page 3-58.
3. Withdraw the handle from the phase assembly.
4. Slowly remove the central bolt and washer from the AC busbar and catch the ACCT and large rubber washer that are secured by the bolt. Remove the ACCT and large rubber washer.
5. Withdraw the AC busbar from the phase assembly.
6. Flip the AC busbar over (see opposite) and slide the AC busbar into position through the end of the Phase Assembly (upper position) and secure the ACCT and large rubber washer with the central bolt and washer. Torque to 42Nm (31 ft.lbf).
7. Fit the handle to the lower position and secure using the two screws. Hand-tighten.
8. Refit the Phase Assembly front panel and secure with four screws and washers.

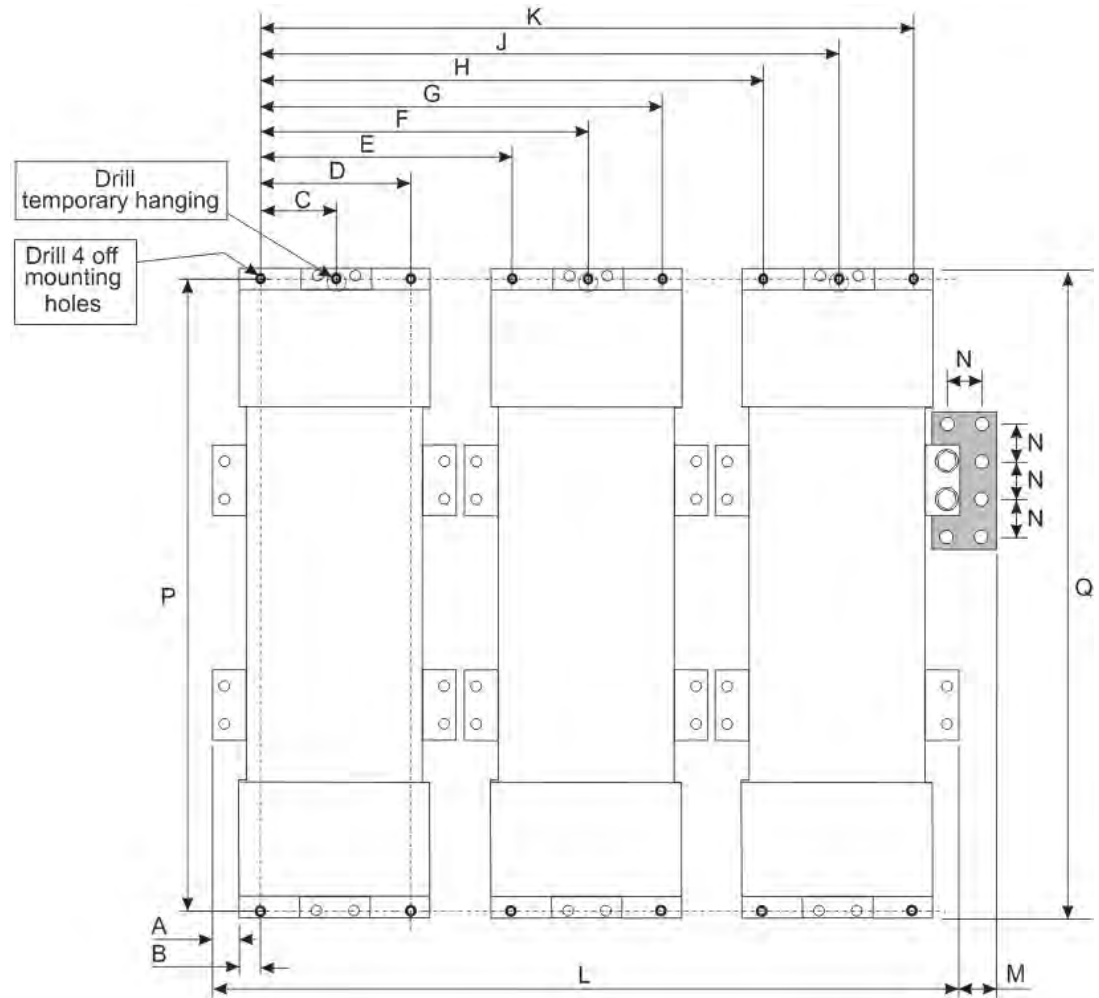


## 3-56 Installing the Drive

### Mounting the Phase Assemblies

The three phase assemblies are mounted vertically onto a solid, flat, vertical backplate inside the cubicle, with the fans at the bottom.

- Temporary Hanging:** A temporary hanging point is provided to hang the unit on before securing the phase assembly to the backplate at the four corners.



<b>A</b>	<b>B</b>	<b>C</b>	<b>D</b>	<b>E</b>	<b>F</b>
24 (0.94)	23 (0.91)	72 (2.83)	144 (5.67)	247.5 (9.74)	319.5 (12.58)
<b>G</b>	<b>H</b>	<b>J</b>	<b>K</b>	<b>L</b>	<b>M</b>
391.5 (15.41)	495 (19.49)	567 (22.32)	639 (25.16)	732 (28.82)	35.5 (1.40)
<b>N</b>	<b>P</b>	<b>Q</b>			
35 (1.38)	678 (26.69)	712 (28.03)			
<i>Dimensions are in millimetres (inches)</i>					



## Backplate Drilling Procedure

Cover any units already mounted to the backplate to protect them from stray metal filings before drilling the mounting holes.

Refer to the diagram on the previous page and drill the mounting holes into the backplate. The holes must be positioned accurately.

For each phase assembly:

- Drill 5 holes to suit M10 flush-fitting inserts. Fit the nut inserts.

**IMPORTANT** *The nut inserts MUST be flush-fitting so that the phase assembly foot rests on the backpanel. If the phase assembly is mounted incorrectly it will damage the moulding.*

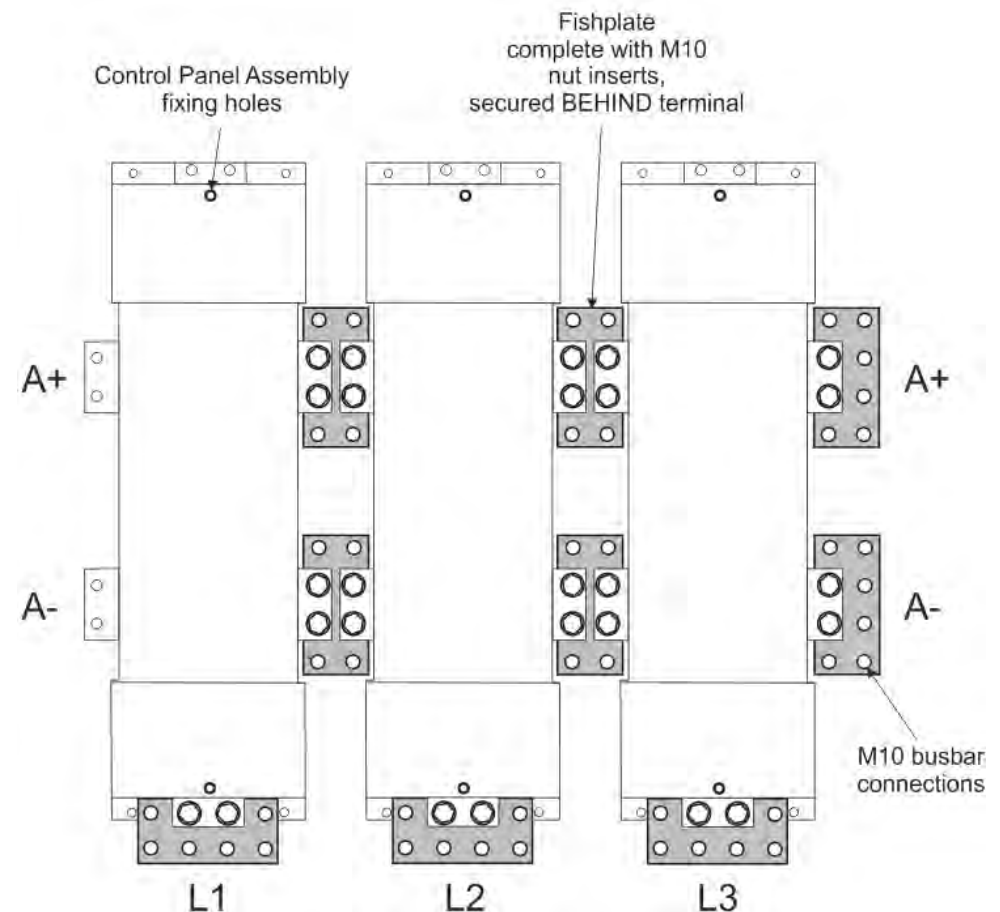
## Connecting the Fishplates

Before fitting the Phase Assemblies to the back panel, loosely fit the fishplates to the right hand side terminals (A+, A-) of each Phase Assembly.

The fishplates are fitted with M10 nut inserts. Secure the fishplates **behind** the terminals using M10 bolts (8:8 steel grade) and spring disc washers (preferred, or single coil spring washer). Hand tighten only.

Fitting the fishplate behind the terminal allows the phase assembly to easily be lifted away from adjacent phase assemblies and any associated busbar connections.

**NOTE** 8:8 minimum steel grade bolts are recommended for all busbar connections and mounting duties.





## Temporary Hanging Bolts

**IMPORTANT**

*We strongly recommend using the temporary mounting hole to hang the unit on the backplate - the phase assemblies are heavy. This mounting point is not intended for permanent fixing.*

- Fit M10 x 20mm long bolts to the three "temporary hanging" mounting holes. Screw them in part of the way so that you can still see 12mm of thread.

The phase assembly will temporarily hang on this portion of thread.

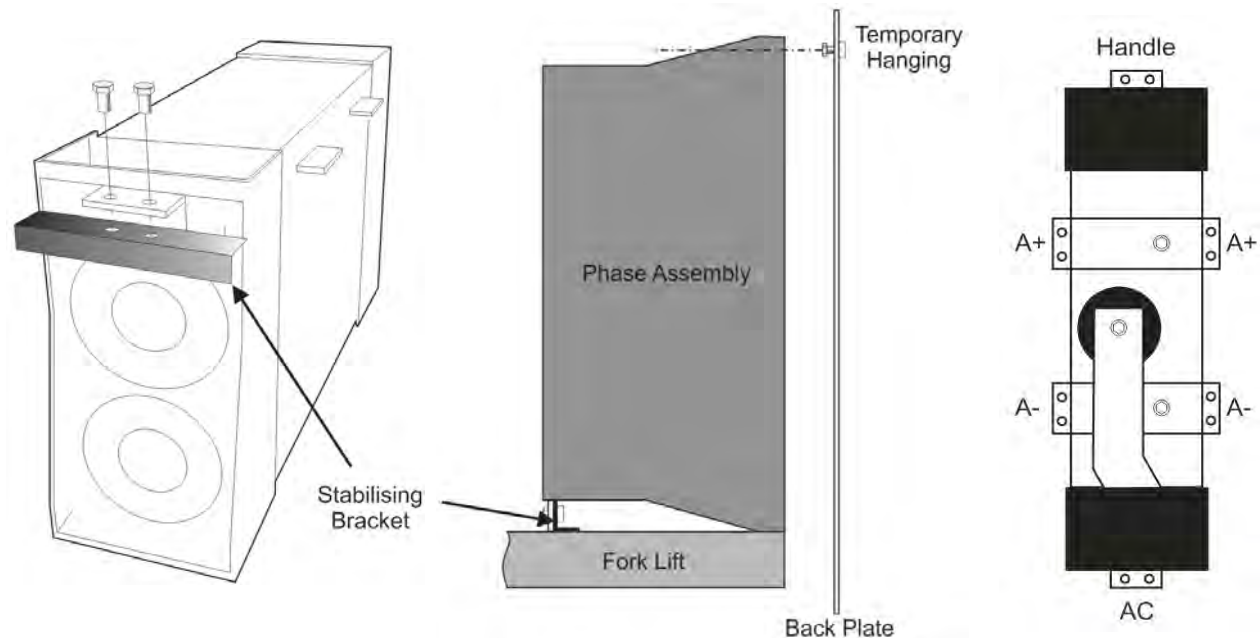
## Offering-Up the Phase Assemblies

The phase assemblies are heavy. Use a proper lifting procedure to load them on to the fork lift. Note that the Phase Assembly is fitted with a handle, opposite the AC terminal, to improve handling.

A stabilising bracket is supplied to steady the phase assembly when using the fork lift. Secure the bracket to the AC terminal using two M10 bolts as shown below.

For each phase assembly:

- Lift the phase assembly by fork lift and hang it on the "temporary hanging" bolt.
- Secure the phase assembly on the backplate using 4 off M10 bolts and lock washers. Hand tighten only.
- Remove the "temporary hanging" bolt.
- Remove the stabilising bracket.



Attach the remaining fishplates:

- To DC motor terminals A+ and A- (whichever pair are to be used)
- To L1, L2 and L3 AC supply terminals

## Tightening the Drive

When all the bolts are in place, tighten them to the following torques:

- mounting bolts (4 per phase assembly) : 32Nm (23.6 ft.lbf)
- fishplate bolts : 32Nm (23.6 ft.lbf)

**Reminder** : Remove the "temporary hanging" bolts.

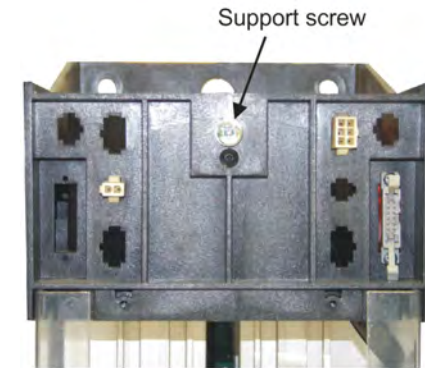
## Fitting the Control Panel Assembly

Fit the M6 x 16mm support screw assemblies [screw, single coil spring washer & plain washer] (A) to the central phase assembly (as shown opposite) and to the equivalent position at the bottom of the phase assembly. Screw them in only part of the way so that the control panel assembly can hang from them.

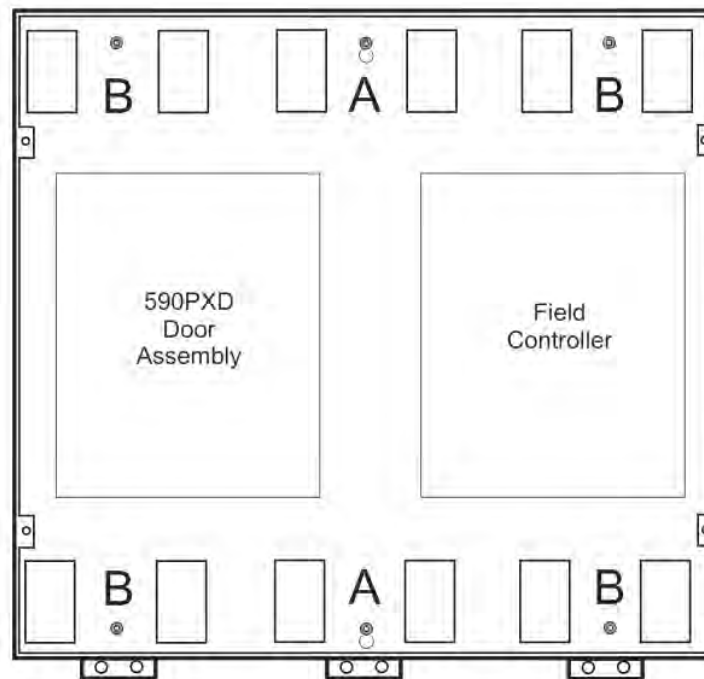
Offer-up the control panel assembly and hang it from the two central support screws (A).

Secure the gantry using the M6 x 16mm support screw assemblies (B).

Tighten all screws to 4.5Nm (3.3 ft.lbf).



Top of central phase assembly



## 3-60 Installing the Drive

### Terminal Connections

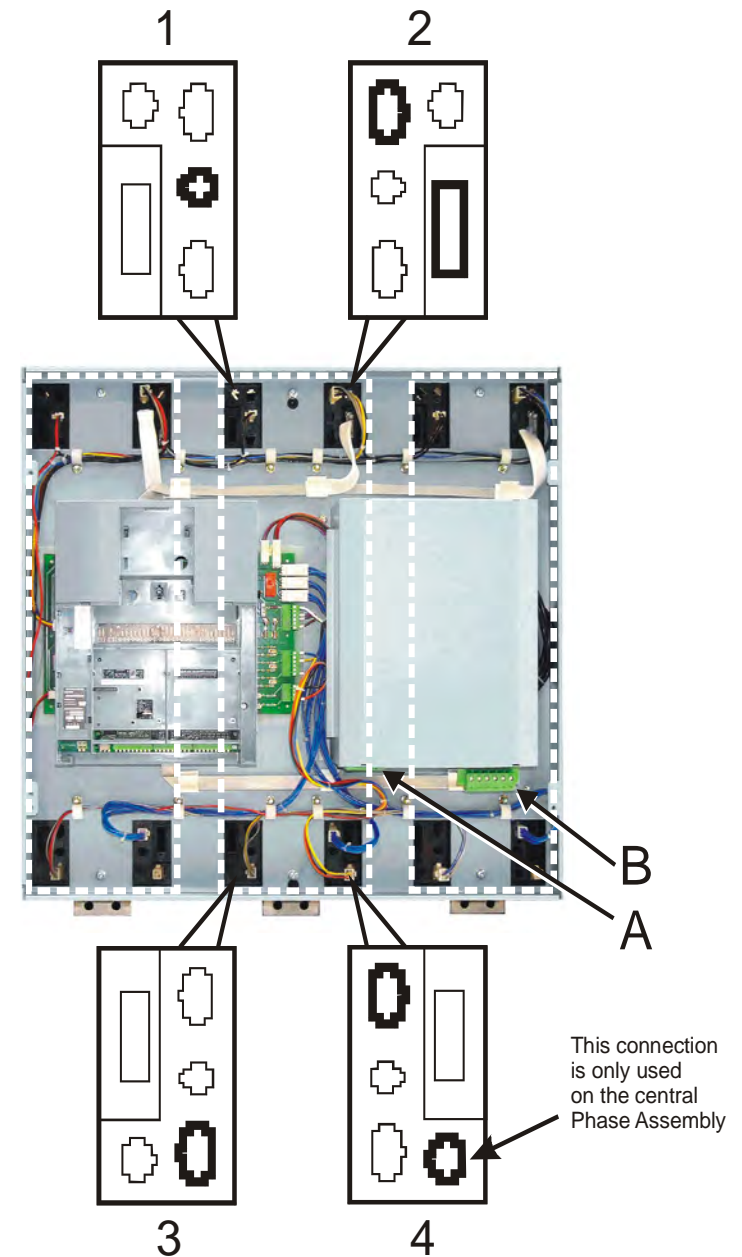
The control panel assembly has connectors for each phase assembly. These are secured in such a way that the cables will only reach the correct terminals set: 1, 2, 3 or 4.

**NOTE** Terminal sets 3 & 4 feature similar 6-way connectors, however one is a male connector and the other a female, so they can't be fitted incorrectly.

Complete the same connections for each phase assembly, plus make the additional armature voltage feedback connection to the central Phase Assembly (shown below). Make sure the terminals are clipped together correctly.

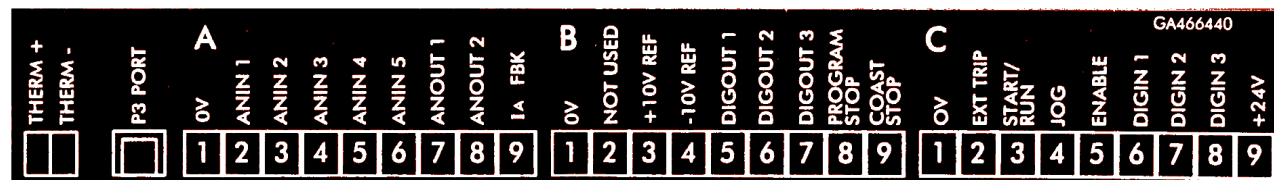
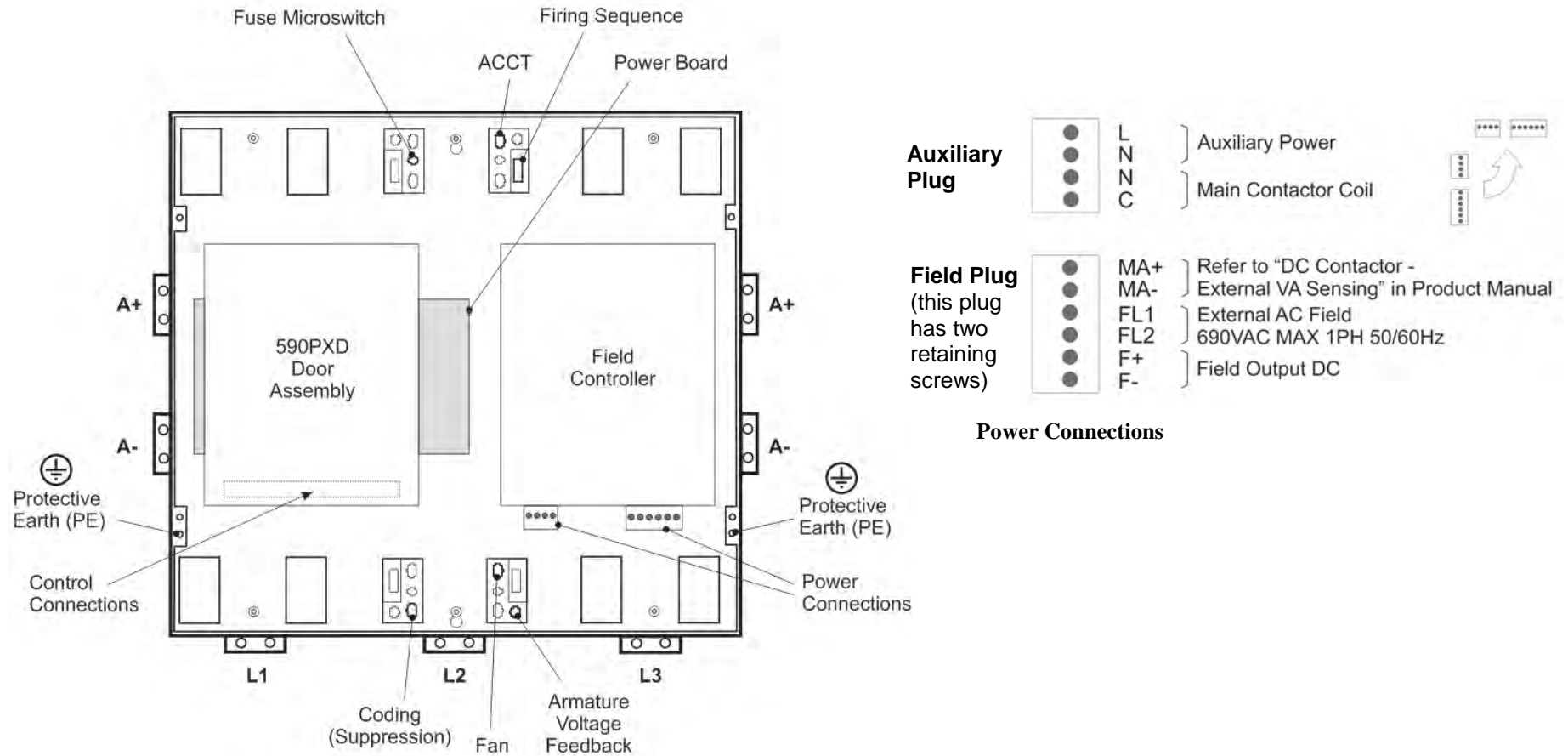
Fit the push-fit control terminals (A) from the control panel assembly. Fit the screw-in power terminals (B).

This completes the building of the DC590+ Drive (other than attaching the front cover).



# Electrical Installation

**IMPORTANT:** Please read the Safety Information on page Cont. 3 & 4 before proceeding.  
 Refer to Electrical Installation, page 3-5 to continue with the drive installation.



Control Connections

## Frame 7: Additional Information

### Removing the Cover (Frame 7)

The cover is manufactured from sheet metal and weighs:-

- 2Q Non-Regenerative = 10kg (22 lbs)
- 4Q Regenerative = 15kg (33 lbs)

To remove the cover use a flat headed screwdriver to undo the two screws at the base of the cover.

Now lift the cover base outwards and upwards, once the cover has been raised two centimetres it can now be removed.

To replace the cover follow the procedure in reverse, engaging the locating studs at the top, moving into final location and tightening fixing screws.

#### NOTE

**This cover is essential for the correct cooling of the drive. If it is not replaced after installation, the drive will overheat.**

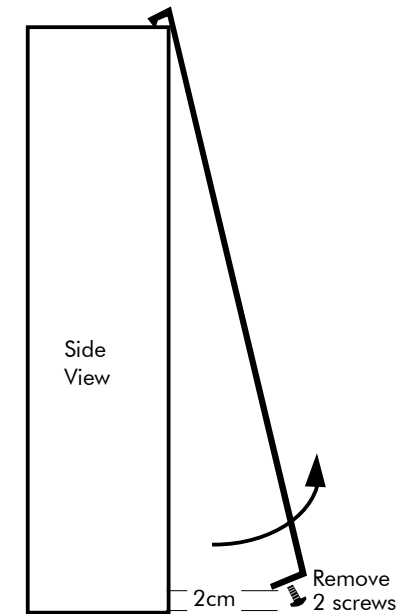
### Changing DC Output Terminals (Frame 7)

- Remove the left-hand cover plate(s) and retain the cover and screws.
- Remove and retain the 12 M6 nuts clamping the outgoing terminals to the cross plates.
- Remove the 12 M6 bolts securing the outgoing busbar assembly. Remove the assembly.
- Carefully remove the gasket(s) for use on the left-hand side.
- Refit the cover to the right-hand side of the drive. Refit the gasket to the left-hand side of the drive.
- Refit the terminal assemblies.

#### NOTE

**The 2Q terminal assembly is not polarised and may be fitted in any orientation. The 4Q terminal assemblies are handed and must be reversed to fit on the left-hand side.**

- Move the terminal markers as appropriate, the A+ terminal will still be at the bottom or AC input at the end of the product.
- **Tighten terminal assembly bolts to the torque given in Appendix E: "Technical Specifications" - Termination Tightening Torque (Frame 7).**

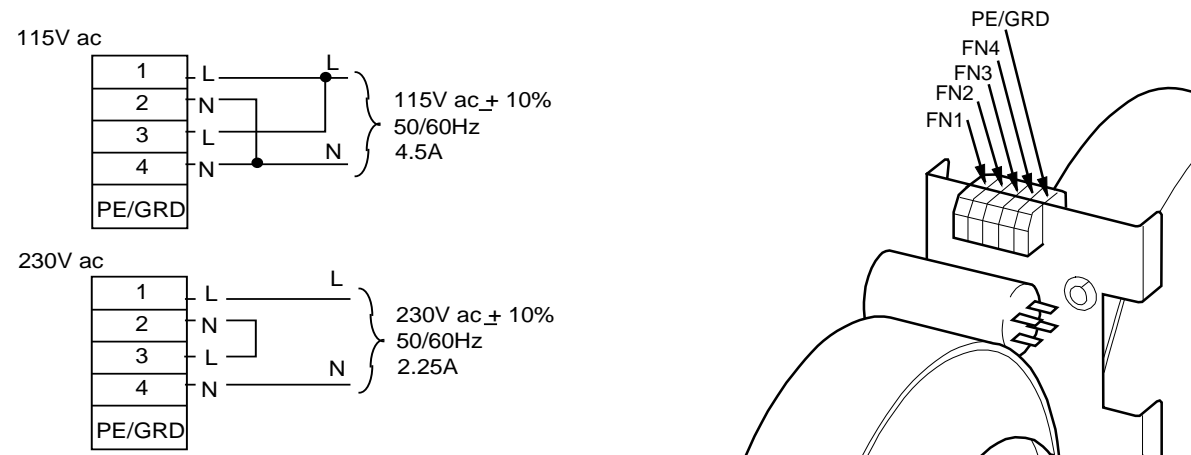


## Installing the Fan (Frame 7)

Refer to Appendix E: “Technical Specifications” - Cooling Fans.

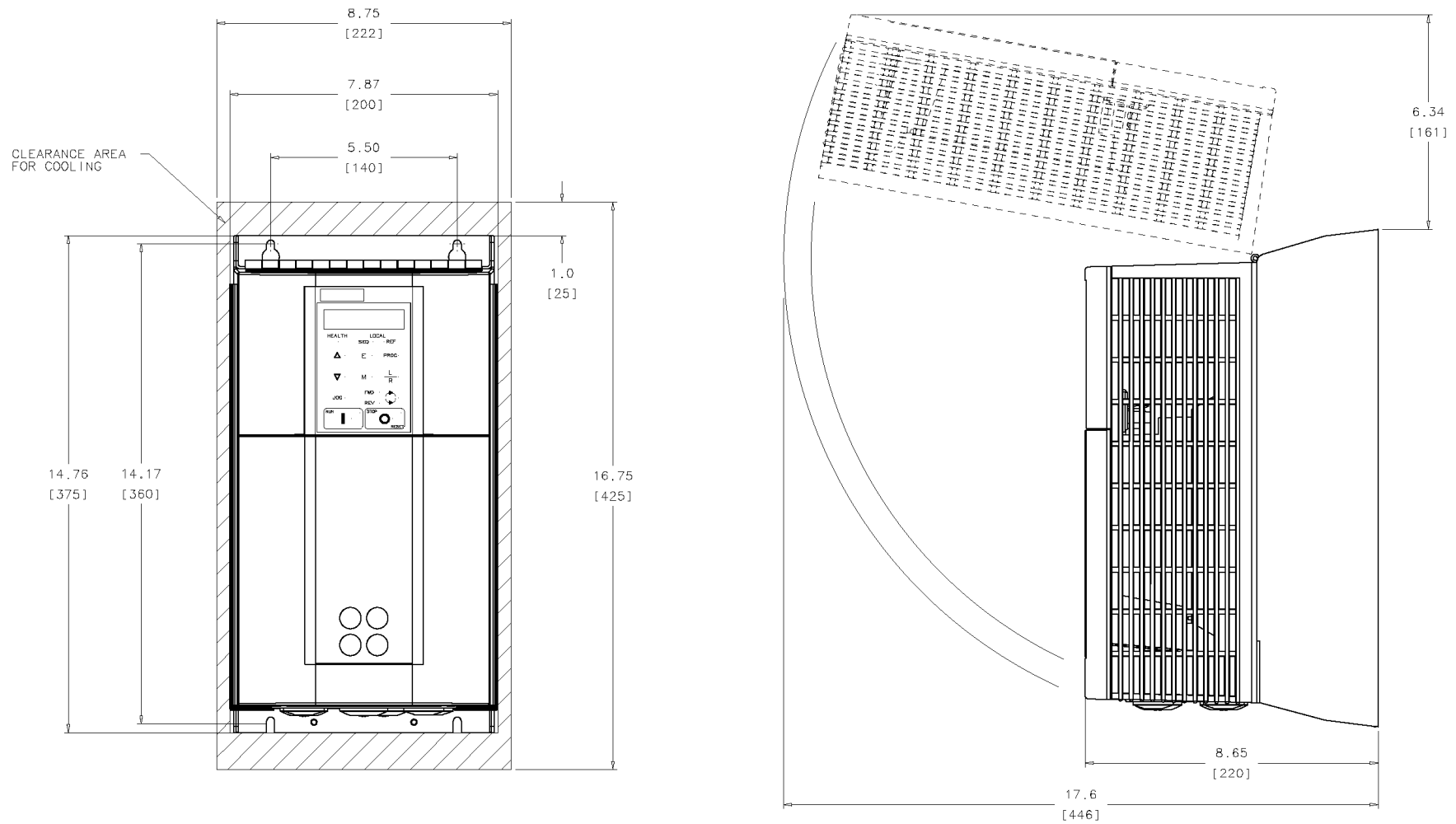
The fan unit supplied should be installed on the cubicle, with or without ducting (refer to the Installation Drawing). The drive is force-cooled using the fan units supplied with the drive. As a general rule allow at least 150mm (6 inches) of clear space above and below the drive for free air flow. We suggest the cubicle has an air inlet at the base of the cubicle equivalent to  $0.37\text{m}^2$  (4ft<sup>2</sup>), variable depending upon the filter type used, to allow the maximum throughput of air.

The fan assembly provided is permanently wired as shown below.



**Figure 3-22 Frame 7 Fan Wiring Diagram**

# Installation Drawings



**Figure 3-23 Frame 1 : 7.5 HP, 20 HP (15A, 35A) Stack Assembly**

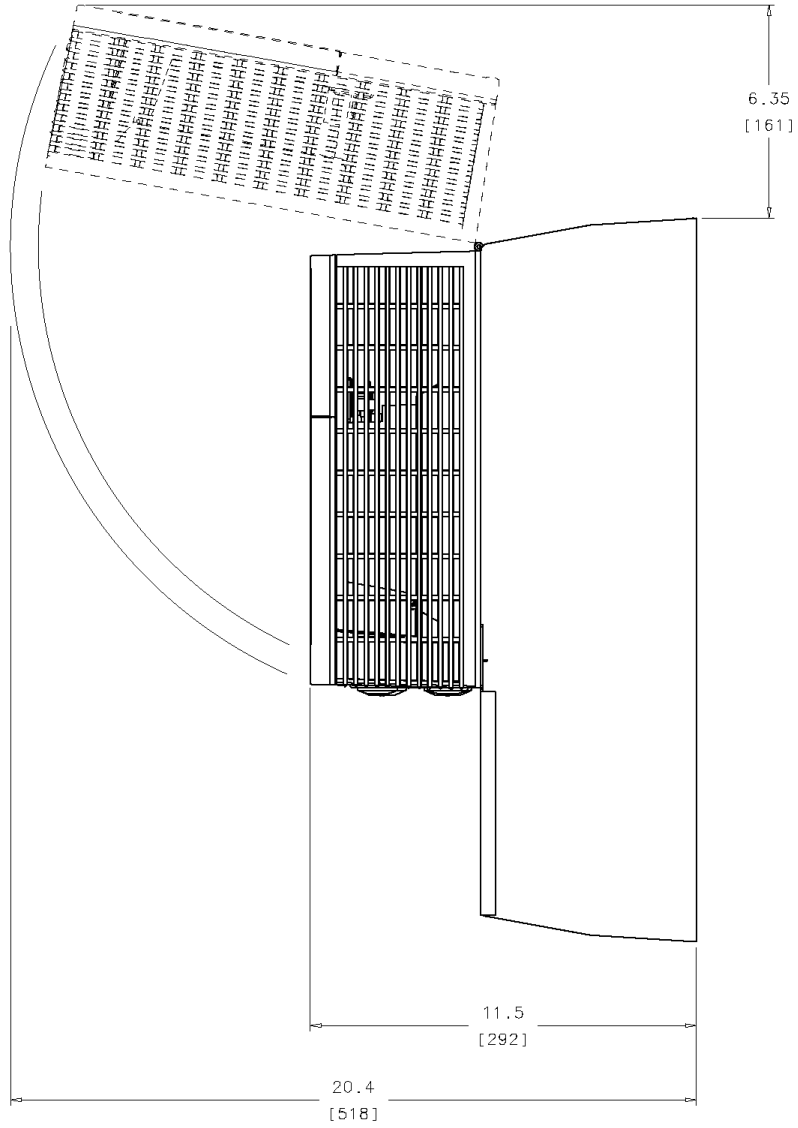
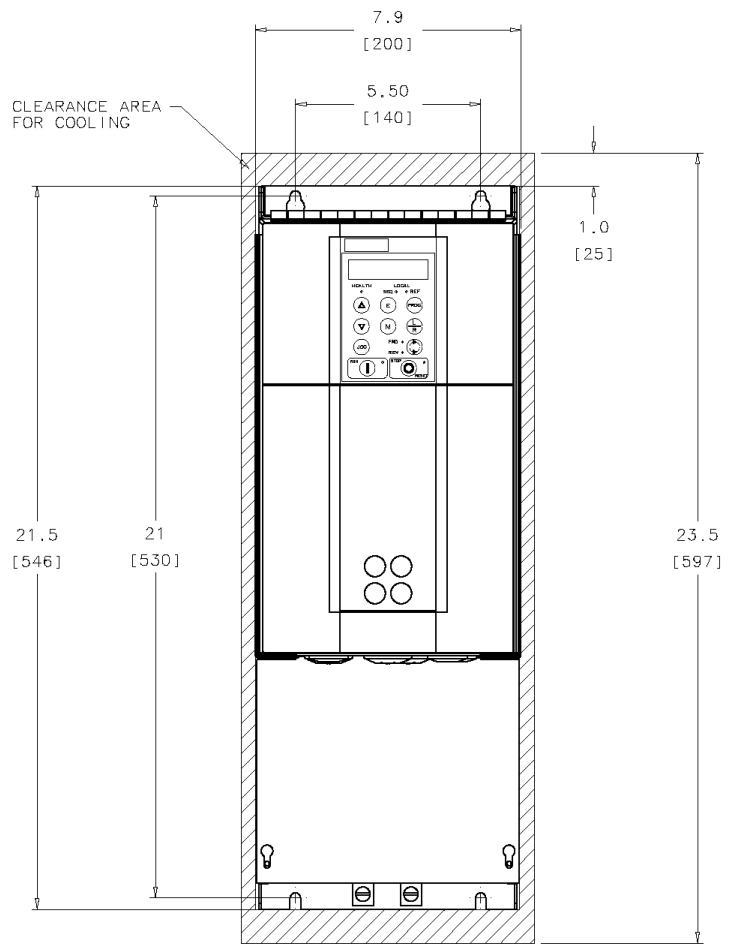
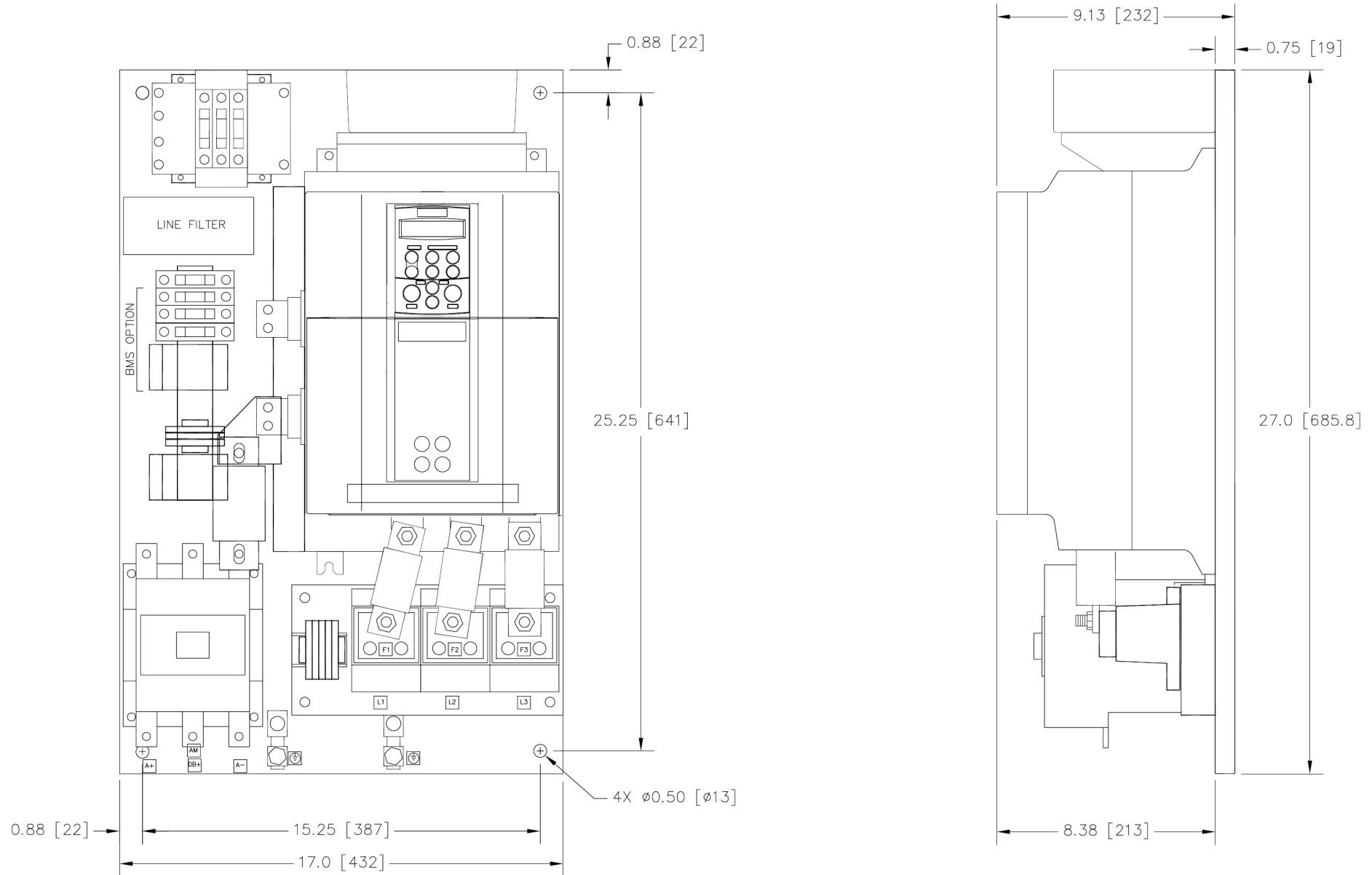


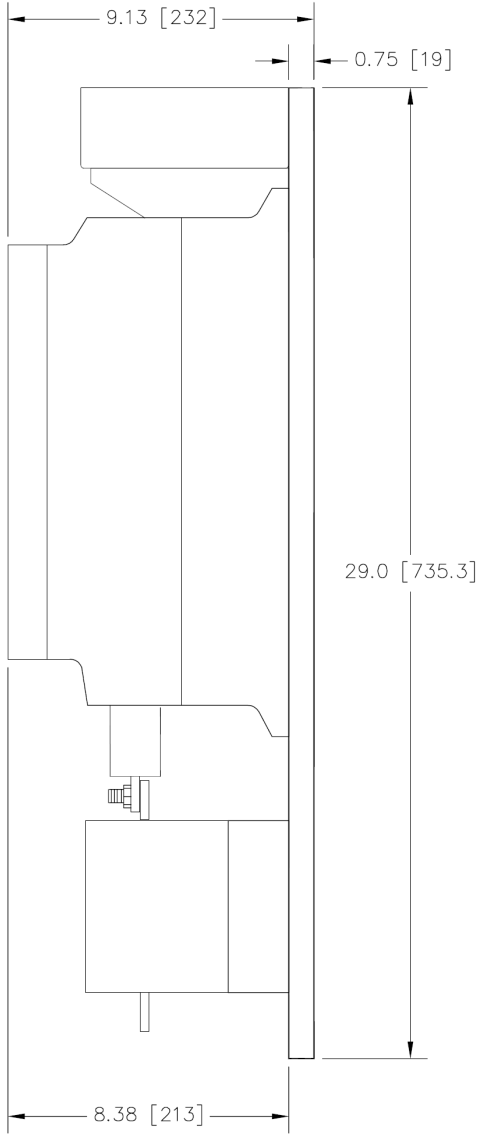
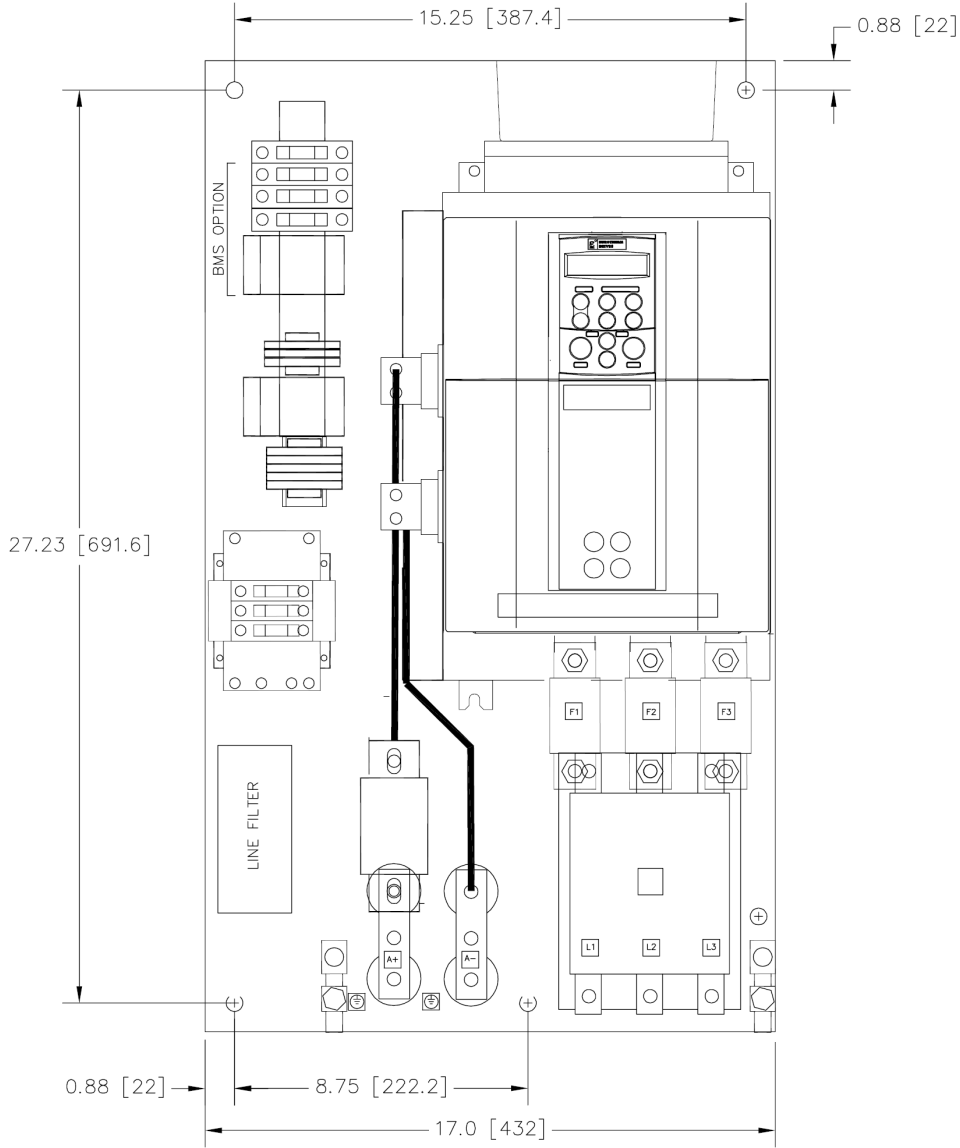
Figure 3-24 Frame 2 : 30-100HP (55A-165A) Stack Assembly



### 3-66 Installing the Drive

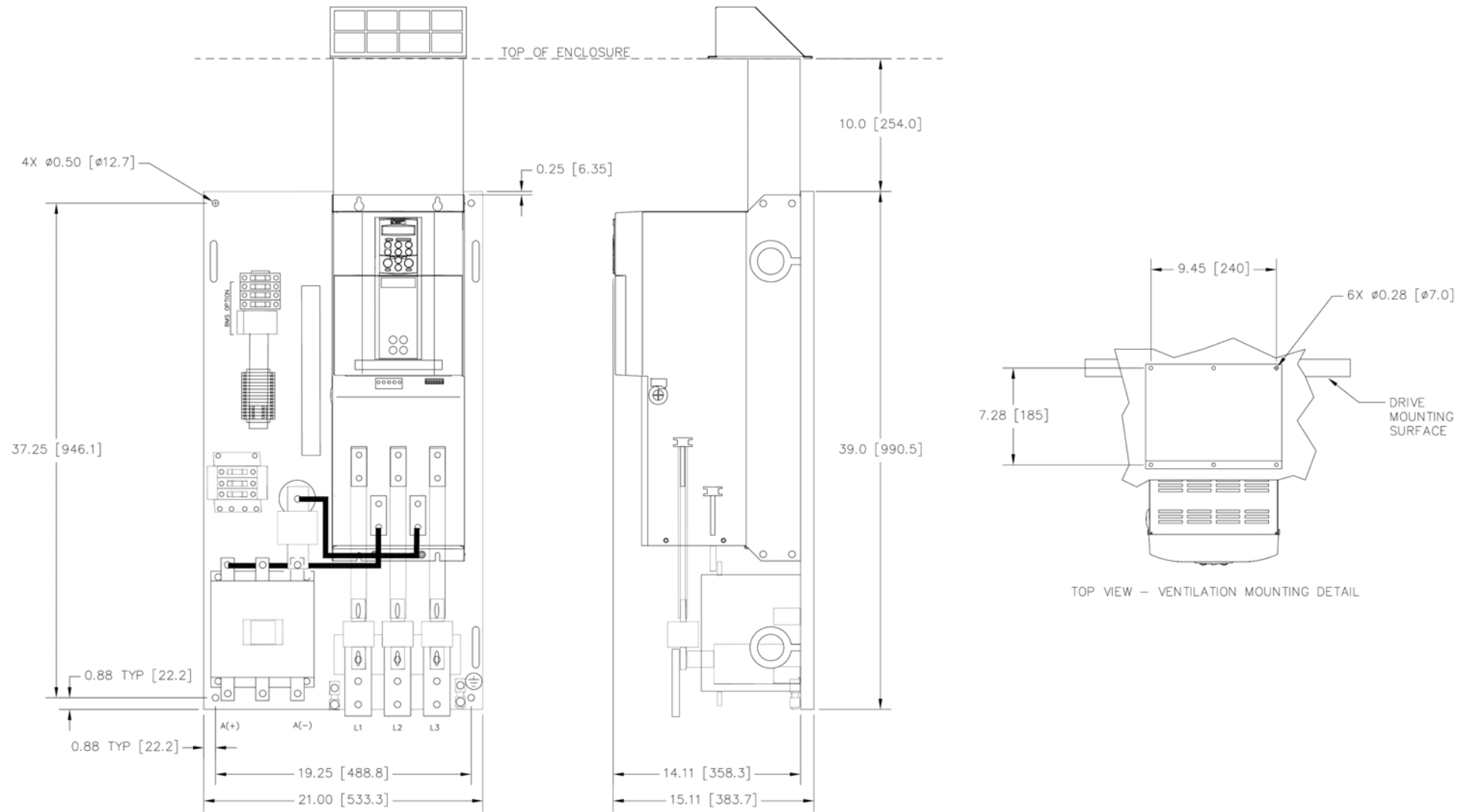


**Figure 3-25 Frame 3 DRV : 125 & 150 HP with 3 Pole Contactor (206A-243A)**

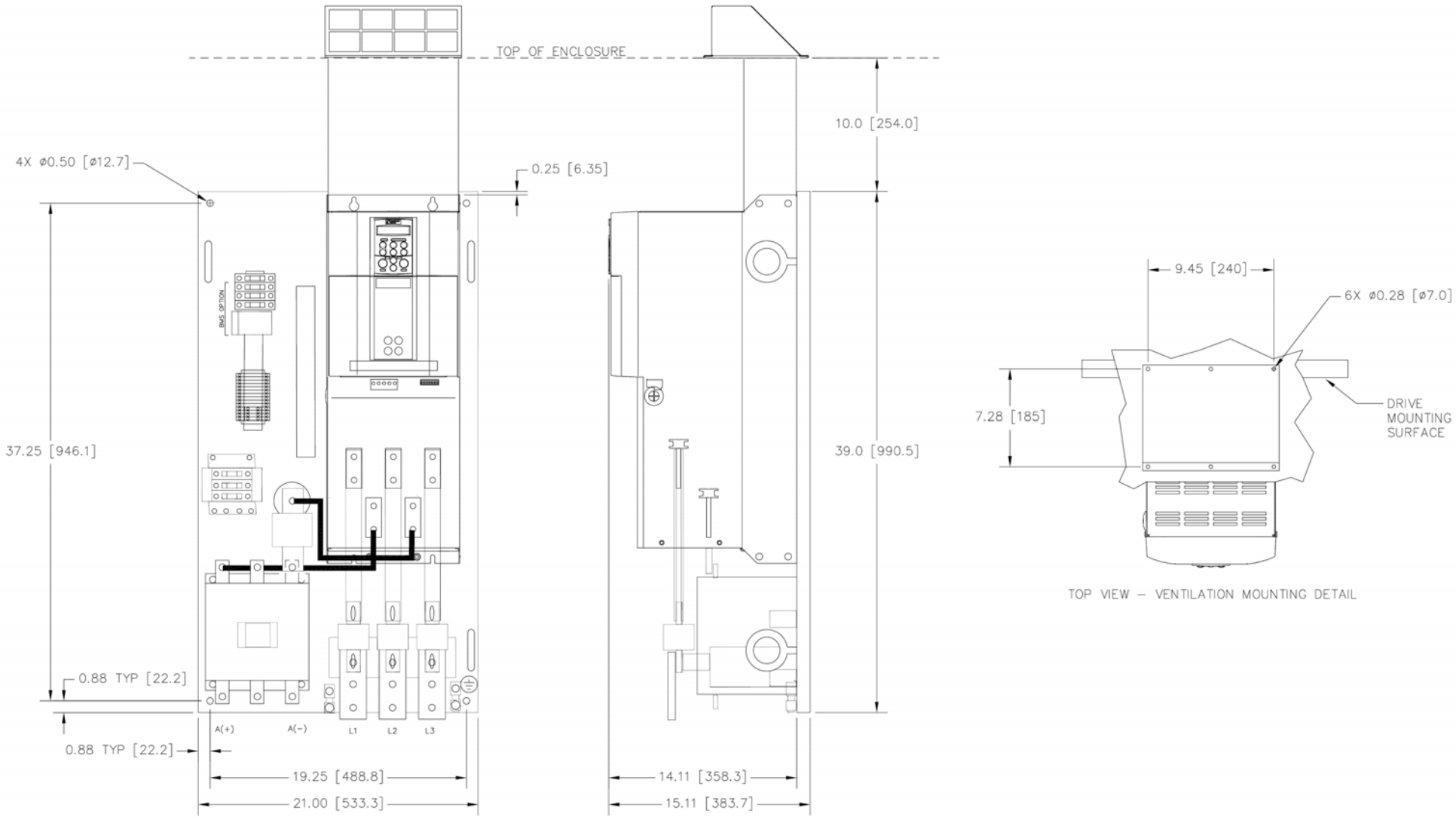


**Figure 3-26 Frame 3 DRV : 125 & 150 HP with AC Contactor (206A-243A)**

# 3-68 Installing the Drive

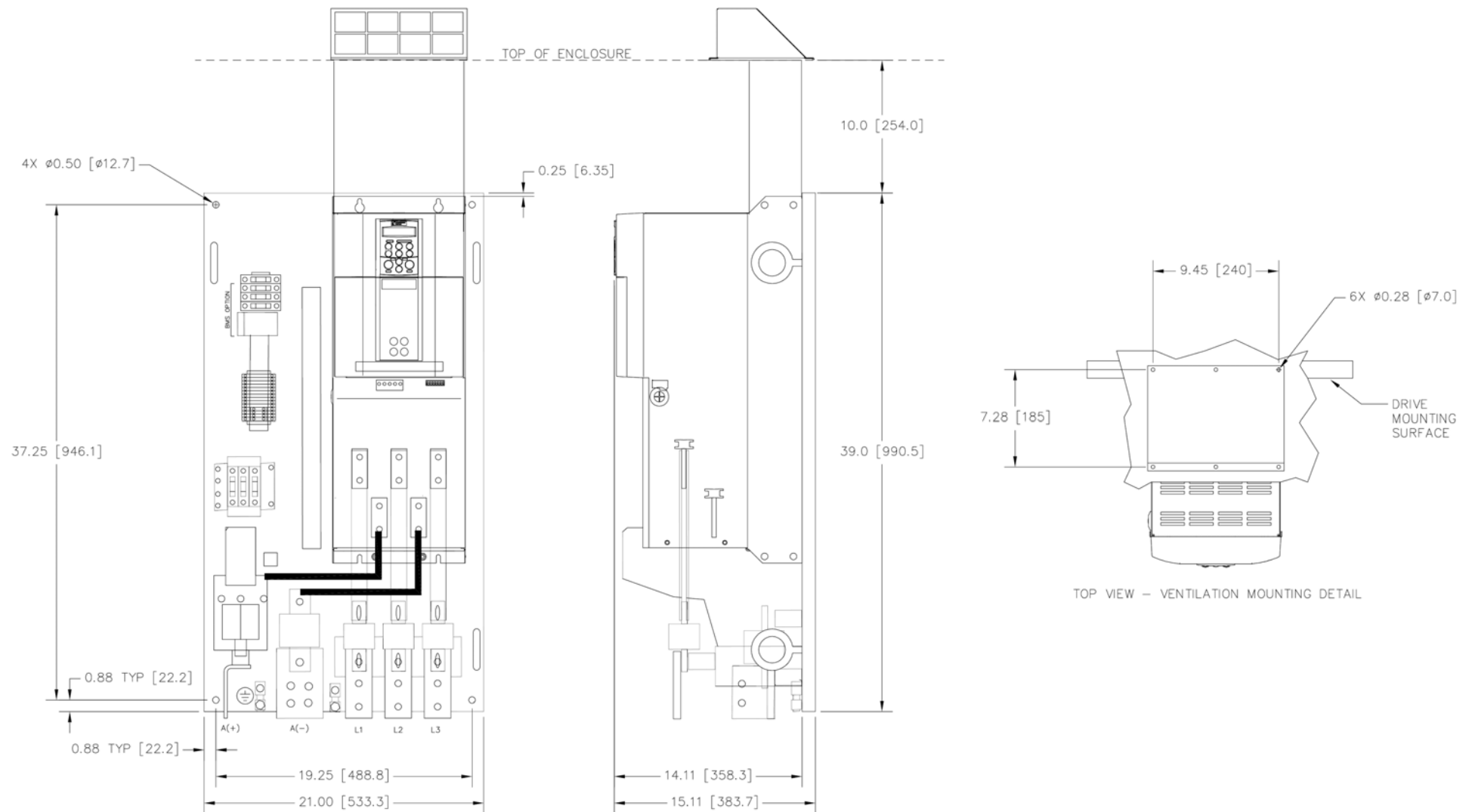


**Figure 3-27 Frame 4 DRV with 3 Pole DC Contactor : 200HP (360A)**



**Figure 3-28 Frame 4 DRV with 3 Pole DC Contactor : 250 - 300HP (425A-490A)**

### 3-70 Installing the Drive



**Figure 3-29 Frame 4 DRV with 1 Pole DC Contactor : 300-500HP (490A-815A)**

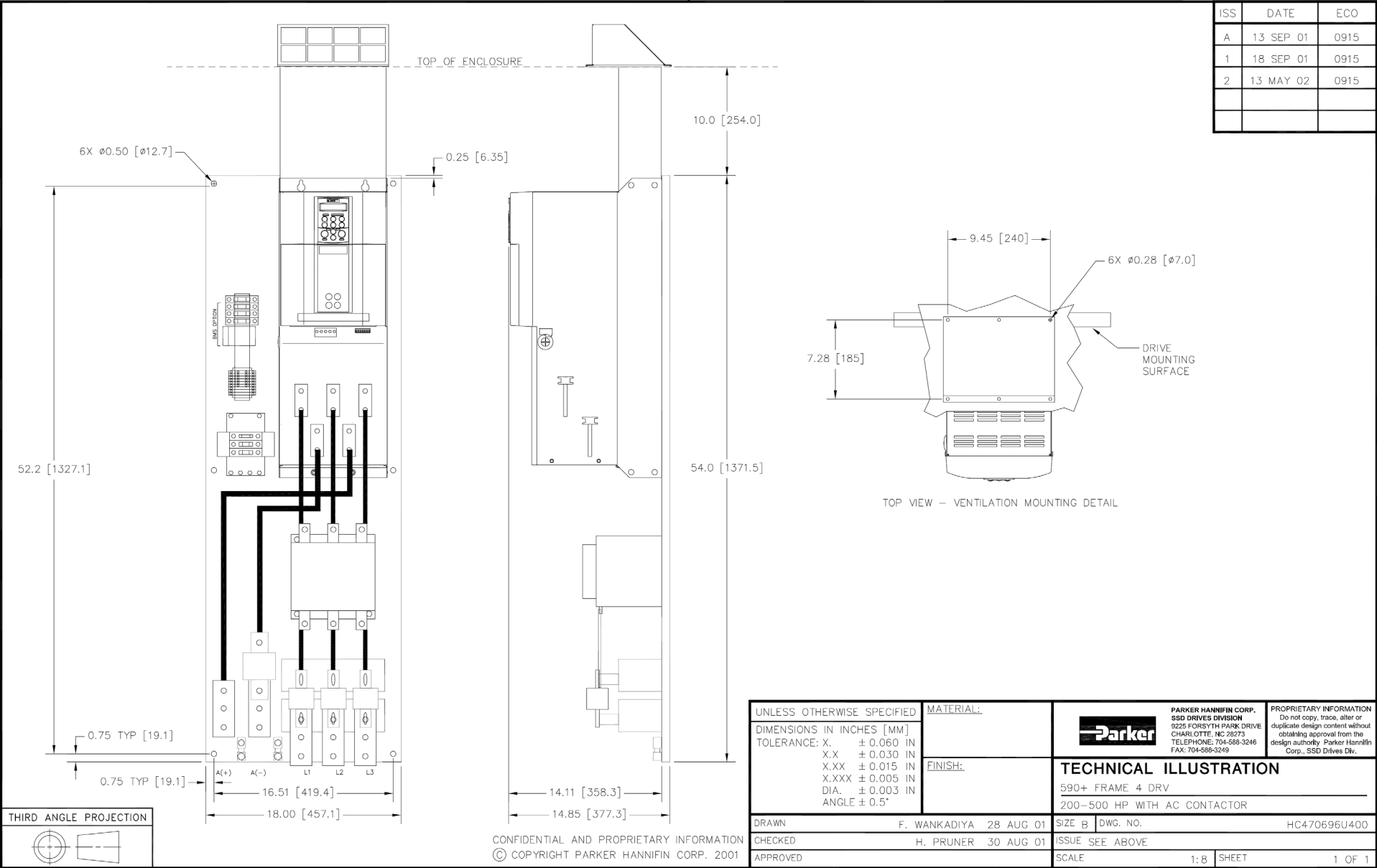
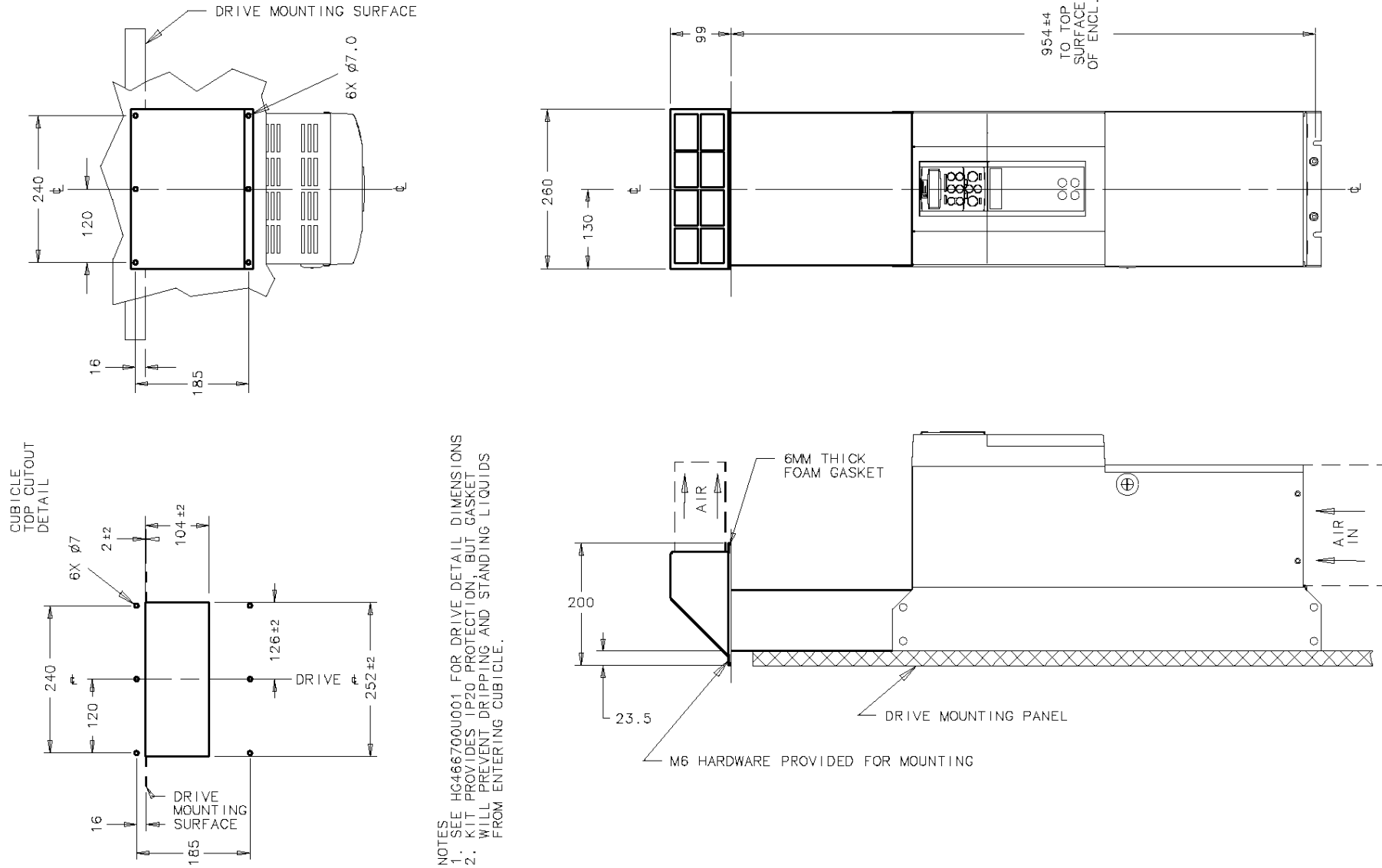


Figure 3-30 Frame 4 DRV with AC Contactor : 200-500 HP (360-815A)

### 3-72 Installing the Drive



NOTES  
 1. SEE HG46700U001 FOR DRIVE DETAIL DIMENSIONS  
 2. KIT PROVIDES IP20 PROTECTION, BUT GASKET WILL PREVENT DRIPPING AND STANDING LIQUIDS FROM ENTERING CUBICLE.

**Figure 3-31 Frame 4 Drive : 200-500 HP (360-815A) External Vent Kit Installation – Drawing No. HG466700U002**

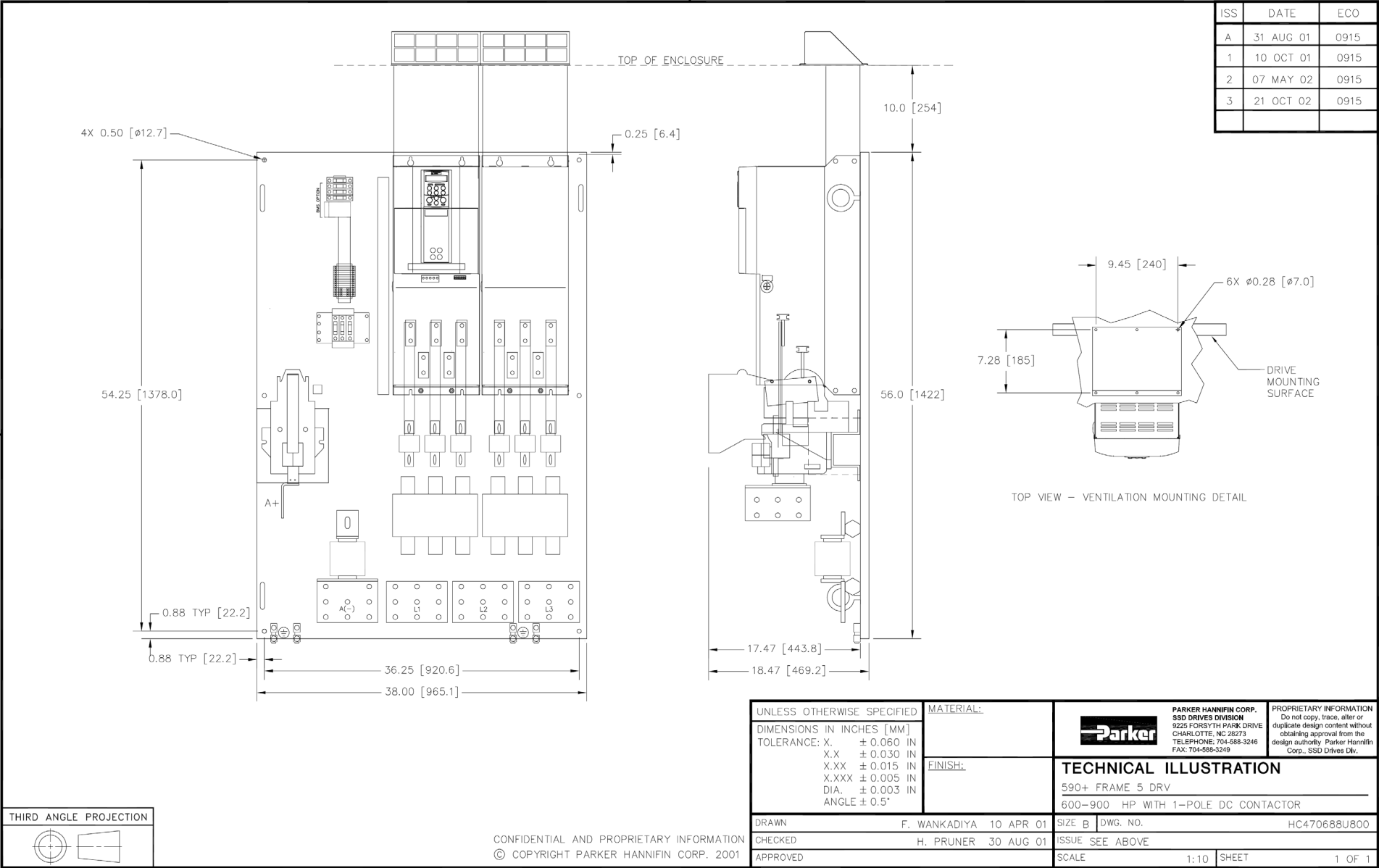
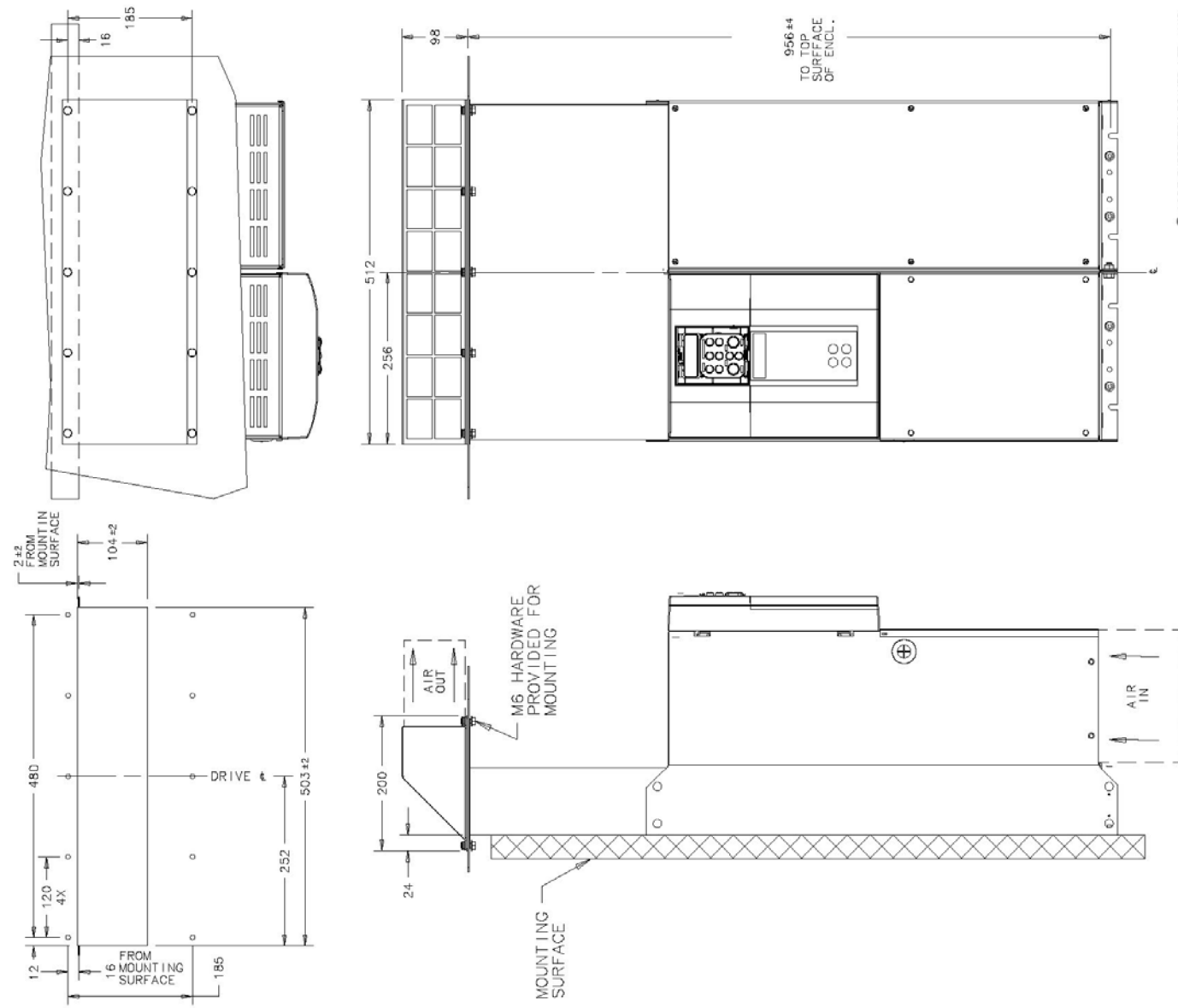


Figure 3-32 Frame 5 DRV with 1 Pole DC Contactor : 600-900 HP (100 - 1580A)

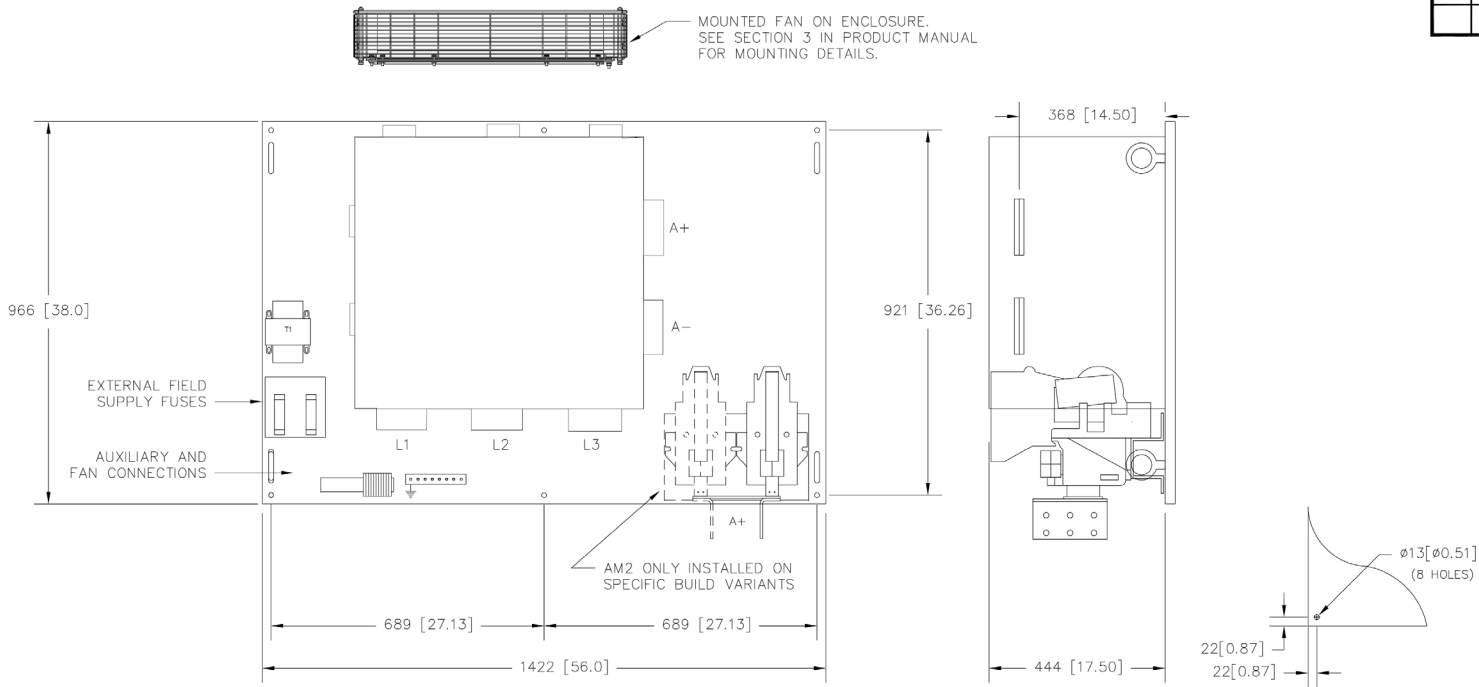


### 3-74 Installing the Drive



**Figure 3-33 Frame 5 Drive : 900 HP (1580A) External Vent Kit Installation – Drawing No. HG466700U111**

ISS	DATE	ECO
A	11 SEP 08	1024



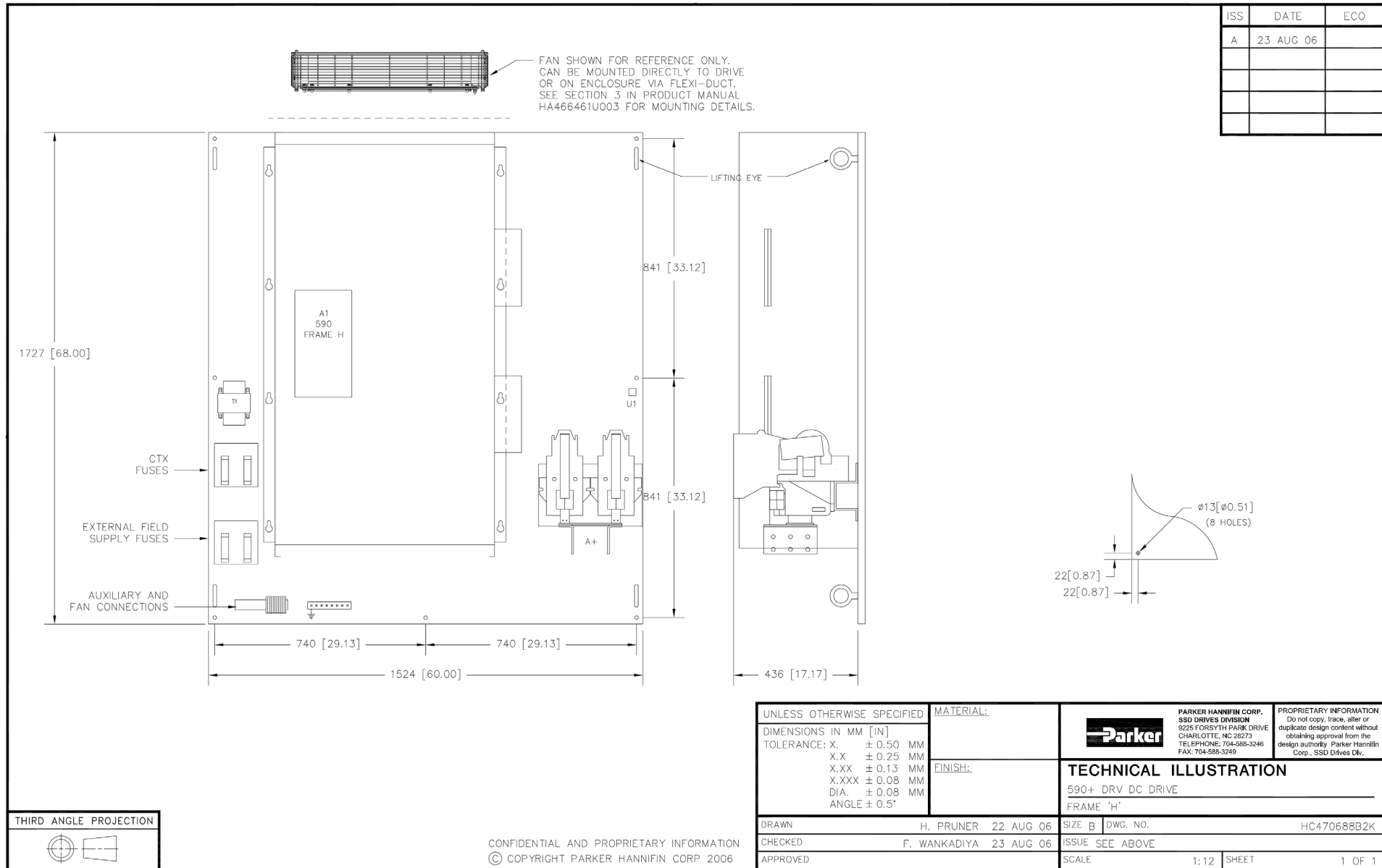
THIRD ANGLE PROJECTION

CONFIDENTIAL AND PROPRIETARY INFORMATION  
 © PARKER HANNIFIN COPR. 2008

UNLESS OTHERWISE SPECIFIED		MATERIAL:		PARKER HANNIFIN CORP. SSD DRIVES DIVISION 3225 FORSYTH PARK DRIVE CHARLOTTE, NC 28273 TELEPHONE: 704-588-3246 FAX: 704-588-3249	PROPRIETARY INFORMATION Do not copy, trace, alter or duplicate design content without obtaining approval from the design authority: Parker Hannifin Corp., SSD Drives Div.
DIMENSIONS IN MM [IN] TOLERANCE: X. ± 0.50 MM X.X ± 0.25 MM X.XX ± 0.13 MM X.XXX ± 0.08 MM DIA. ± 0.08 MM ANGLE ± 0.5°		FINISH:			
DRAWN H. PRUNER 14 MAR 08 CHECKED — APPROVED —				TECHNICAL ILLUSTRATION 590+ DRV DC DRIVE FRAME 6 SIZE B DWG. NO. HC470688B1200 ISSUE SEE ABOVE SCALE 1:12 SHEET 1 OF 1	

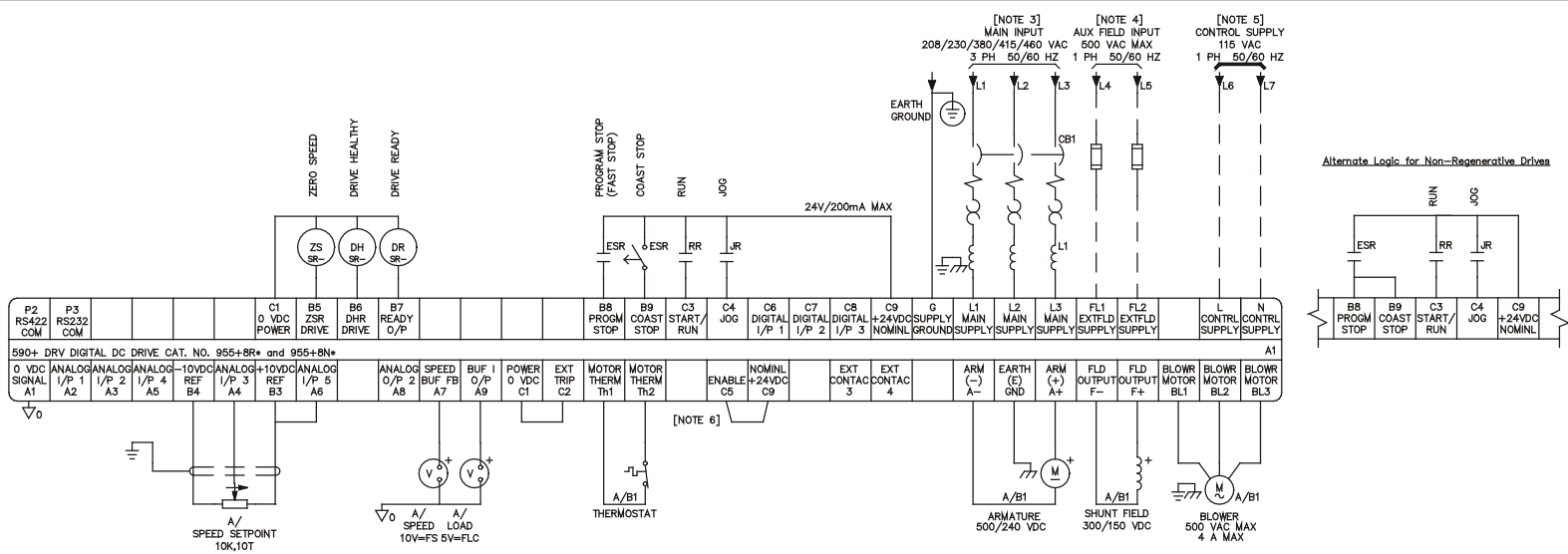
Figure 3-34 Frame 6 Drive : 700 - 1200 HP with 1 Pole DC Contactor

# 3-76 Installing the Drive



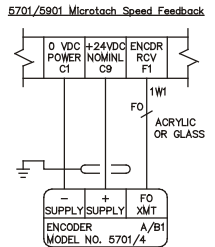
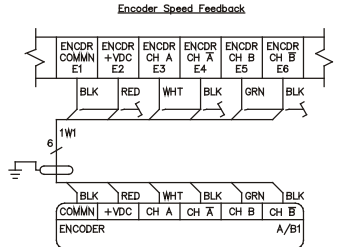
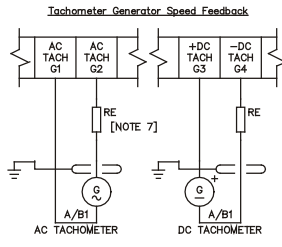
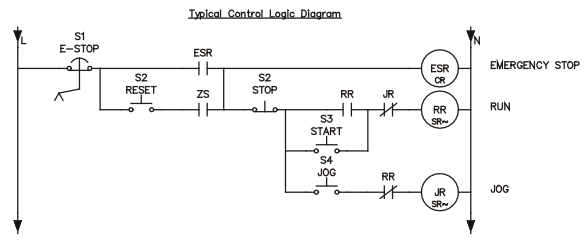
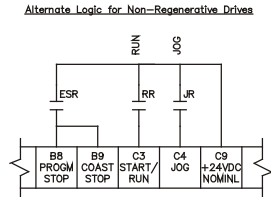
**Figure 3-35 Frame 7 Drive : 1000 - 2000 HP with 1 Pole DC Contactor**

# Connection Diagrams



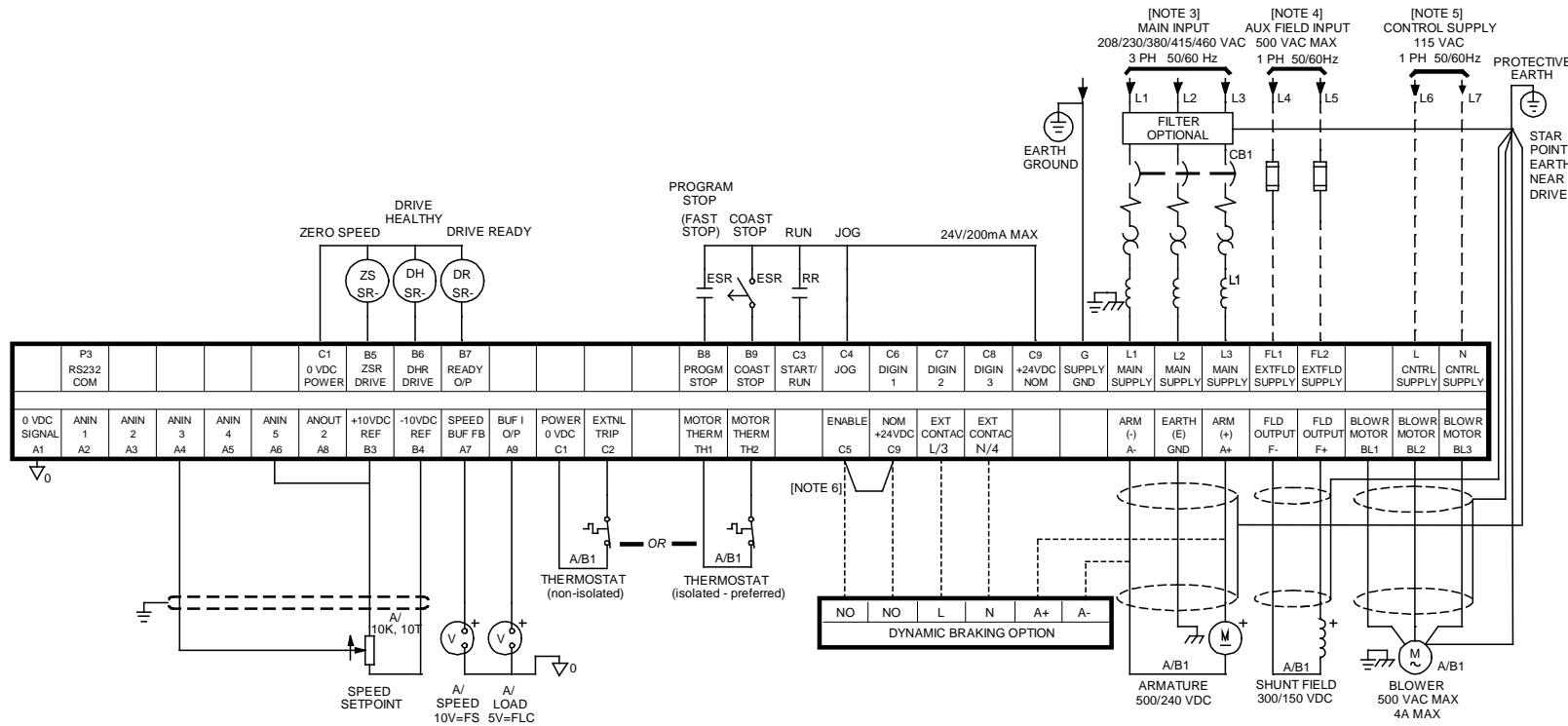
**NOTES**

- Internal armature voltage speed feedback shown.
- Verify hardware checks. (Details in chapter 3)
  - Control transformer taps set for the correct supply, if applicable.
  - Field supply selected for internal or external supply? Does not apply to frame 1.
  - Calibration for tachometer feedback voltage
  - Blower motor starter trip setting, if fitted.
- User must provide branch circuit protection. AC current = 0.83 x DC armature current.
- Branch circuit and overload protection to be fitted by customer. Does not apply to frame 1.
- Do not connect external control power if using the control transformer option.
- The enable input C5 needs to be true (24V) to run the drive. If using the dynamic braking option, remove the jumper across C5,C9.
- Resistor RE is required when full speed tachometer voltage exceeds 199V. If switch setting = ss and input voltage = Vin, then RE = [(50Vin/ss) - 50] Kohms

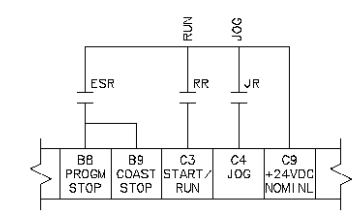


**Frames 1 & 2 DRV : 7.5-100 HP - Minimum Connection Diagram ( ' general purpose' configuration)**

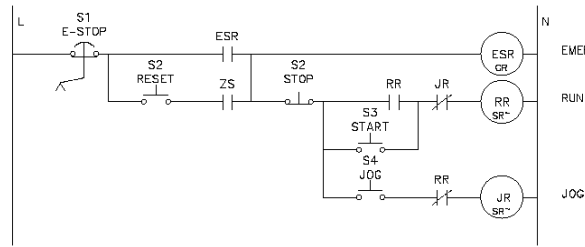
# 3-78 Installing the Drive



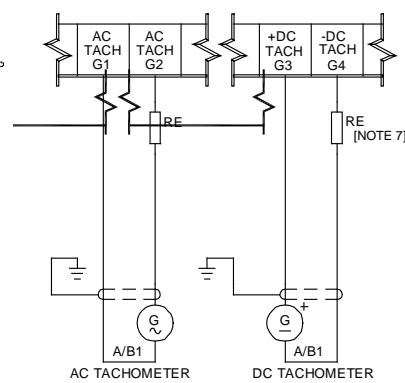
- NOTES
- Internal armature voltage speed feedback shown.
  - Verify hardware checks. (Details in Chapter 3)
    - \* Control transformer taps set for the correct supply, if applicable.
    - \* Field supply selected for internal or external supply? Does not apply to frame 1.
    - \* Calibration for tachometer feedback voltage
    - \* Blower motor starter trip setting, if fitted.
  - User must provide branch circuit protection. AC current = 0.83 x DC armature current.
  - Branch circuit and overload protection to be fitted by customer. Does not apply to frame 1.
  - Do not connect external control power if using the control transformer option.
  - The enable input C5 needs to be true (24V) to run the drive. If using the dynamic braking option, remove the jumper across C5, C9.
  - Resistor RE is required when full speed tachometer voltage exceeds 199V. If switch setting = ss and input voltage = Vin, then RE = [(50Vin/ss) - 50] Kohms



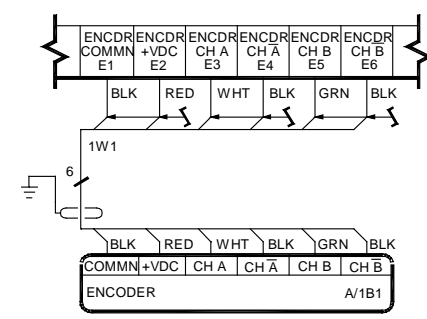
TYPICAL CONTROL LOGIC DIAGRAM



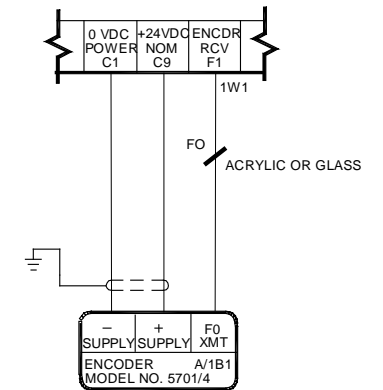
TACHOMETER GENERATOR SPEED FEEDBACK



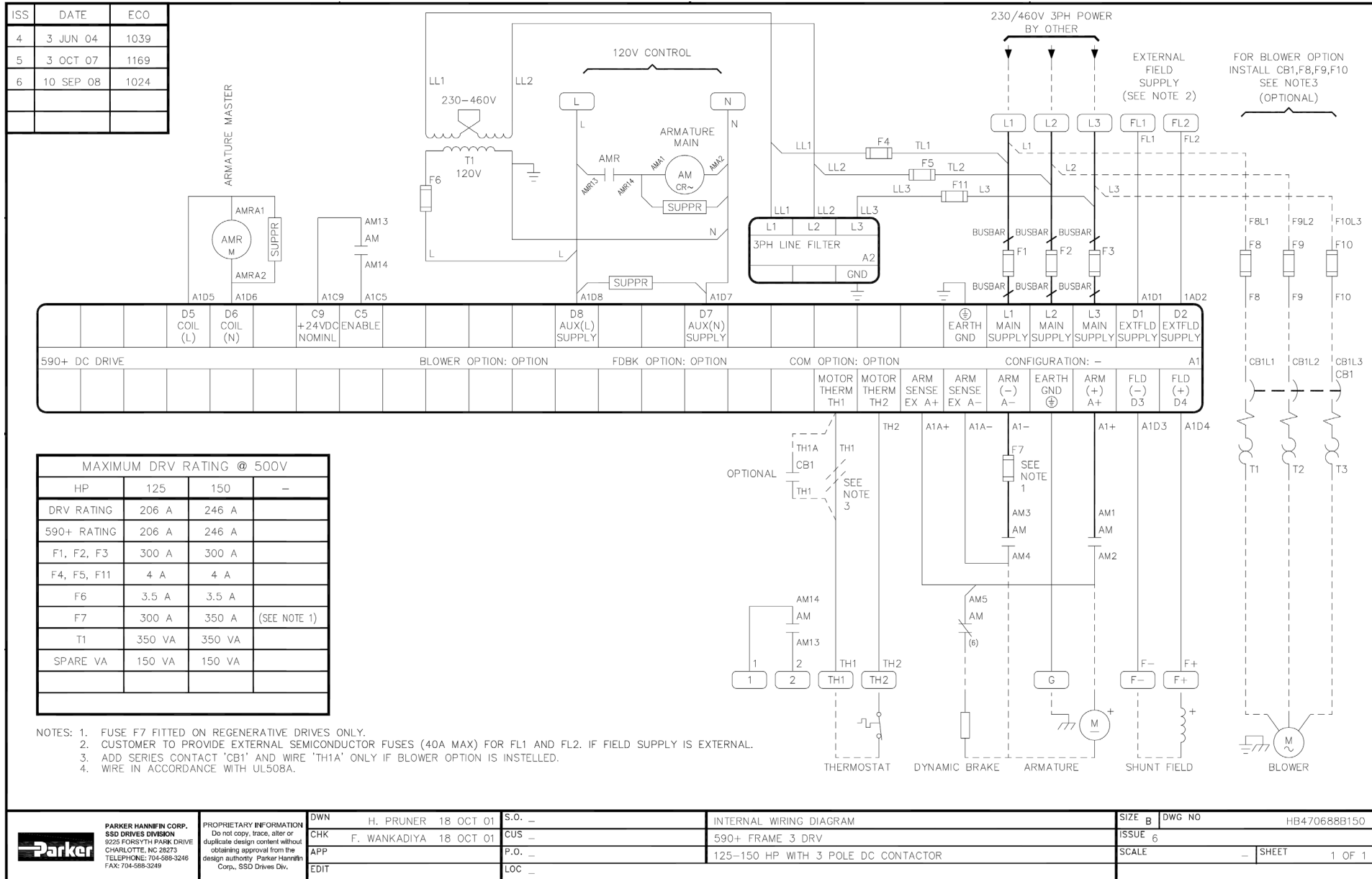
ENCODER SPEED FEEDBACK



5701/5901 MICROTACH SPEED FEEDBACK

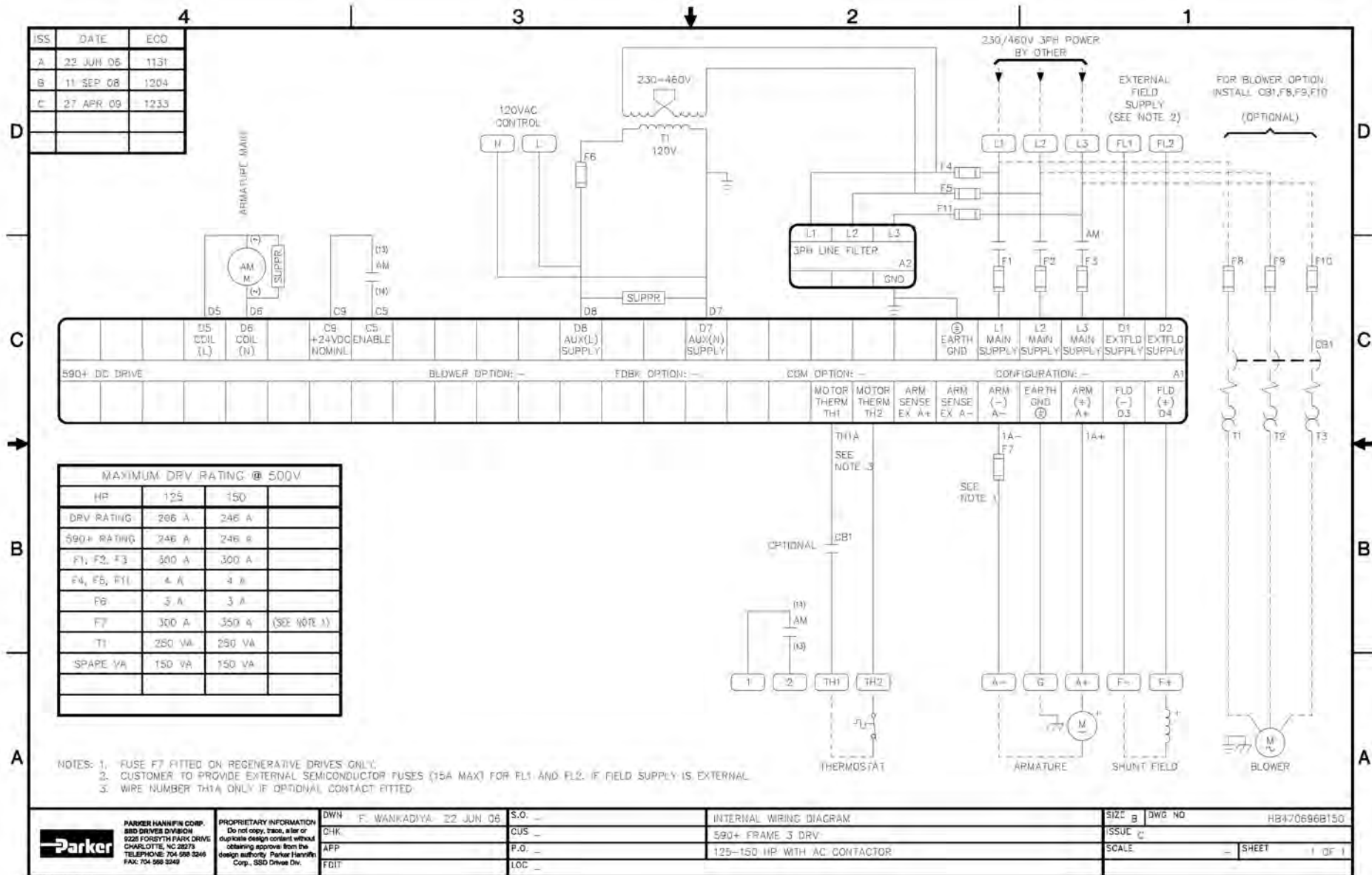


## Frames 1 & 2 DRV : 7.5-100 HP - Minimum Connection Diagram for EMC ('general purpose' configuration)



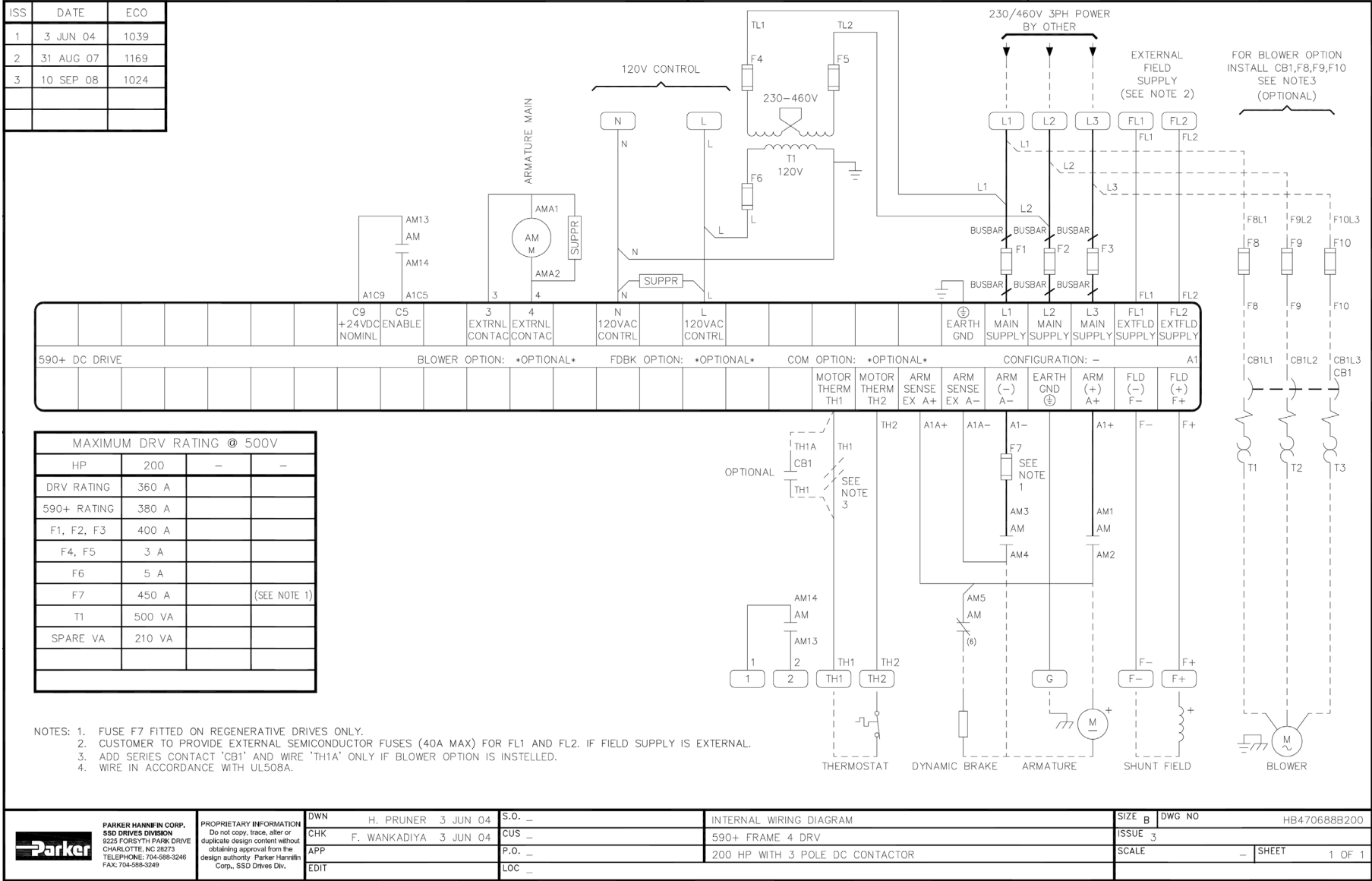
**Frame 3 DRV : 125-150 HP with 3 Pole Contactor - Minimum Connection Diagram for EMC (general purpose configuration)**

# 3-80 Installing the Drive



Frame 3 DRV : 125-150 HP with AC Contactor - Minimum Connection Diagram for EMC ('general purpose' configuration)

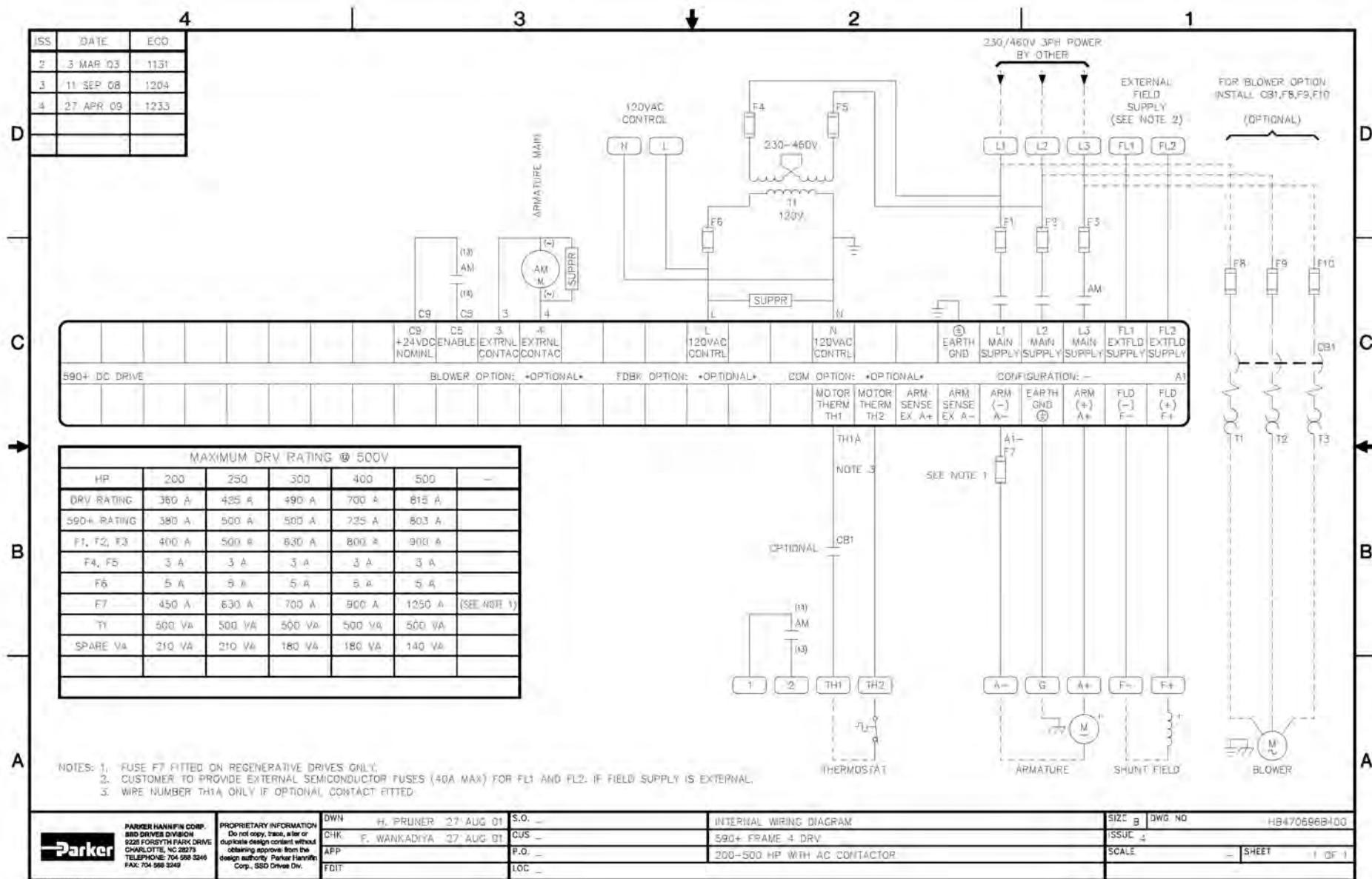
ISS	DATE	ECO
1	3 JUN 04	1039
2	31 AUG 07	1169
3	10 SEP 08	1024



**Frame 4 DRV : 200 HP with 3 Pole DC Contactor - Minimum Connection Diagram (‘general purpose’ configuration)**

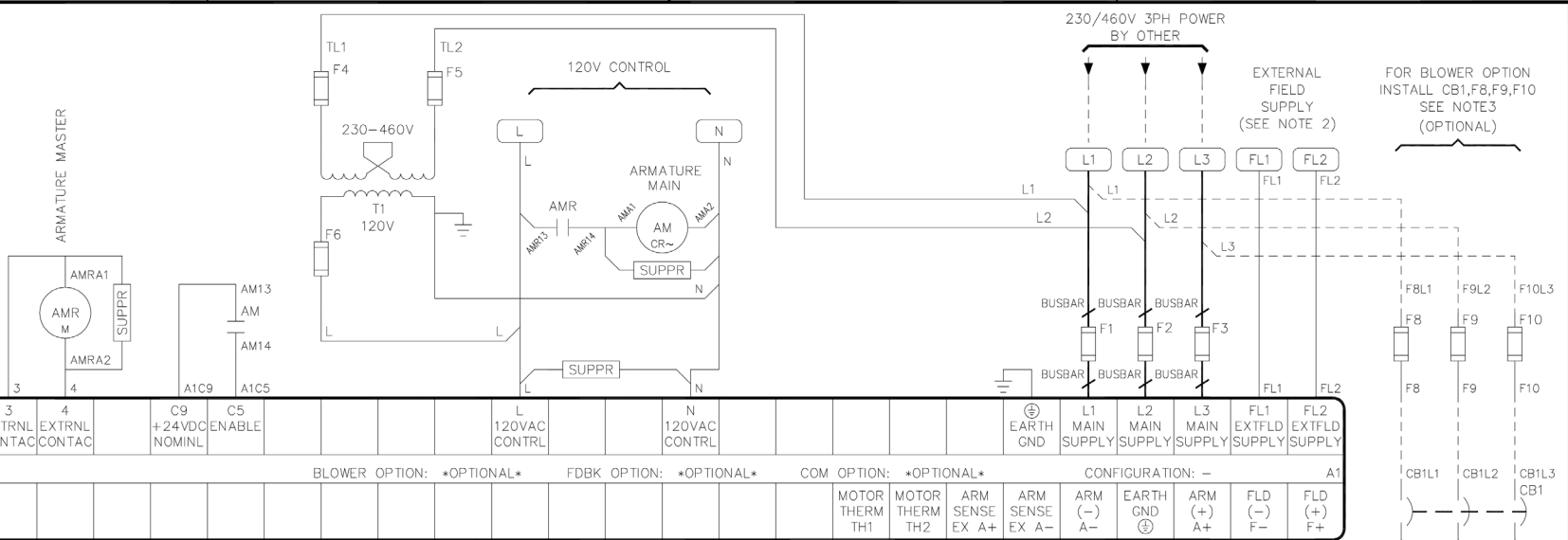


# 3-82 Installing the Drive



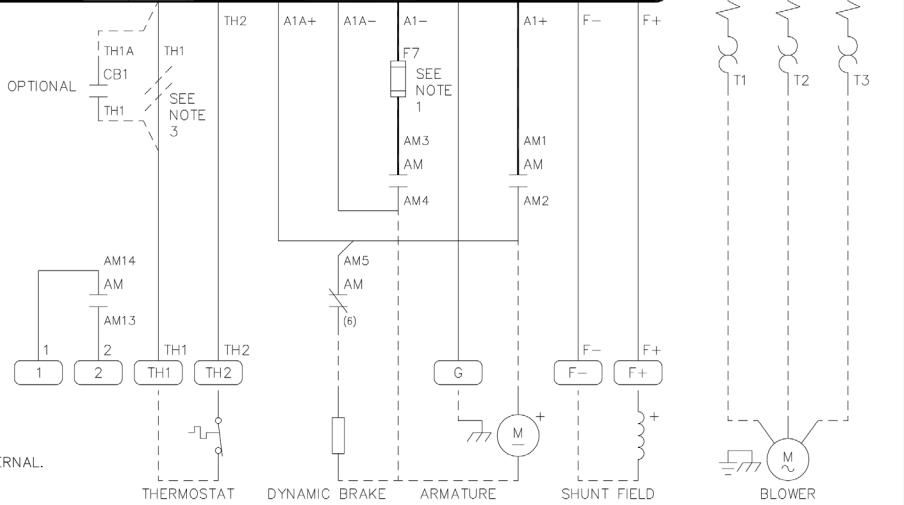
**Frame 4 DRV : 200-500 HP with AC Contactor - Minimum Connection Diagram (‘general purpose’ configuration)**

ISS	DATE	ECO
3	3 JUN 04	1039
4	26 MAY 05	1059
5	29 MAY 07	1162
6	2 OCT 07	1169
7	10 SEP 08	1204



MAXIMUM DRV RATING @ 500V			
HP	250	++300	-
DRV RATING	425 A	490 A	
590+ RATING	500 A	500 A	
F1, F2, F3	500 A	630 A	
F4, F5	6.25 A	6.25 A	
F6	7 A	7 A	
F7	630 A	700 A	(SEE NOTE 1)
T1	750 VA	750 VA	
SPARE VA	420 VA	420 VA	

\*\* SPECIAL BUILD 240V VERSION NOT AVAILABLE

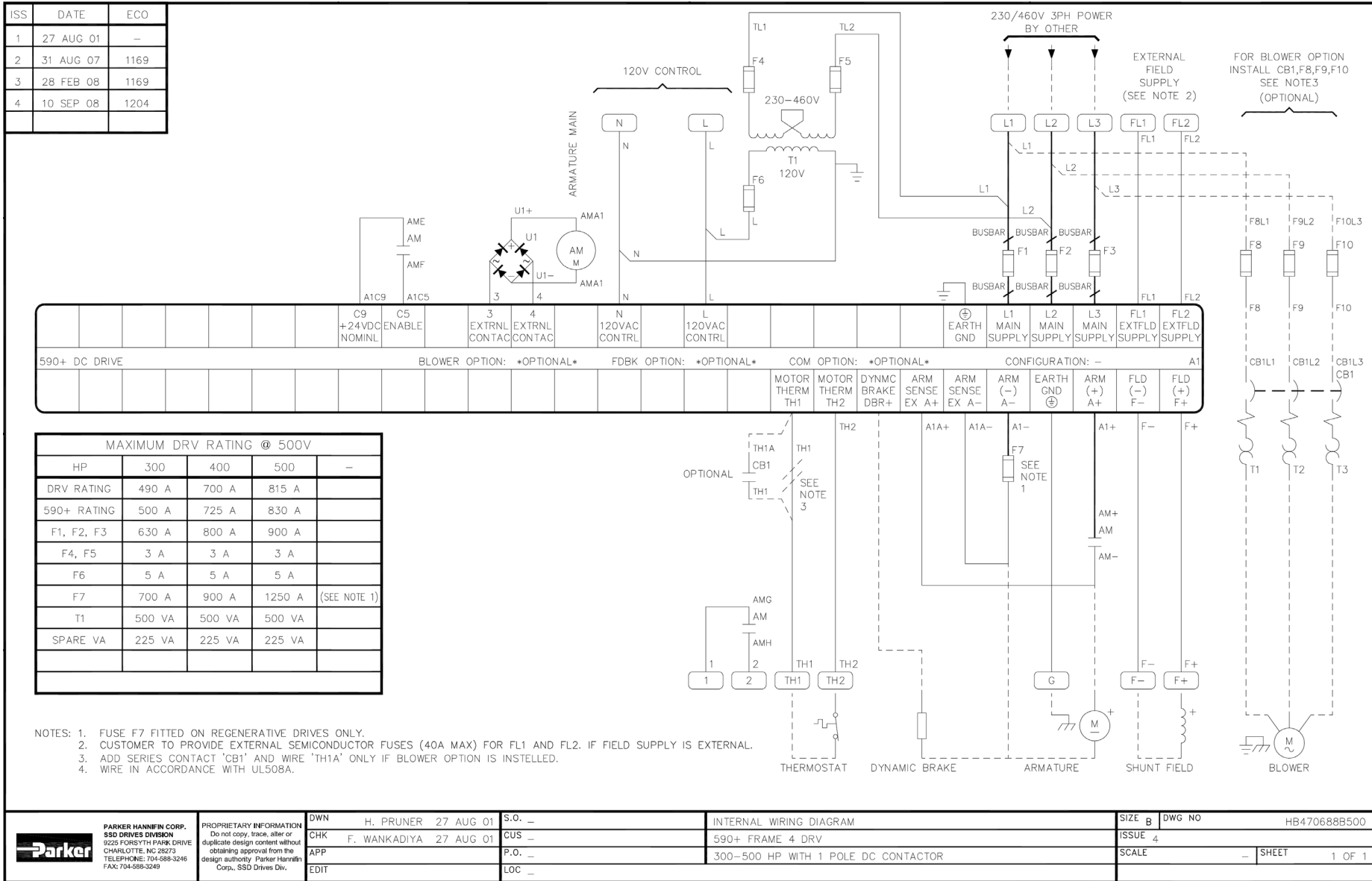


- NOTES: 1. FUSE F7 FITTED ON REGENERATIVE DRIVES ONLY.  
 2. CUSTOMER TO PROVIDE EXTERNAL SEMICONDUCTOR FUSES (40A MAX) FOR FL1 AND FL2. IF FIELD SUPPLY IS EXTERNAL.  
 3. ADD SERIES CONTACT 'CB1' AND WIRE 'TH1A' ONLY IF BLOWER OPTION IS INSTALLED.  
 4. WIRE IN ACCORDANCE WITH UL508A.

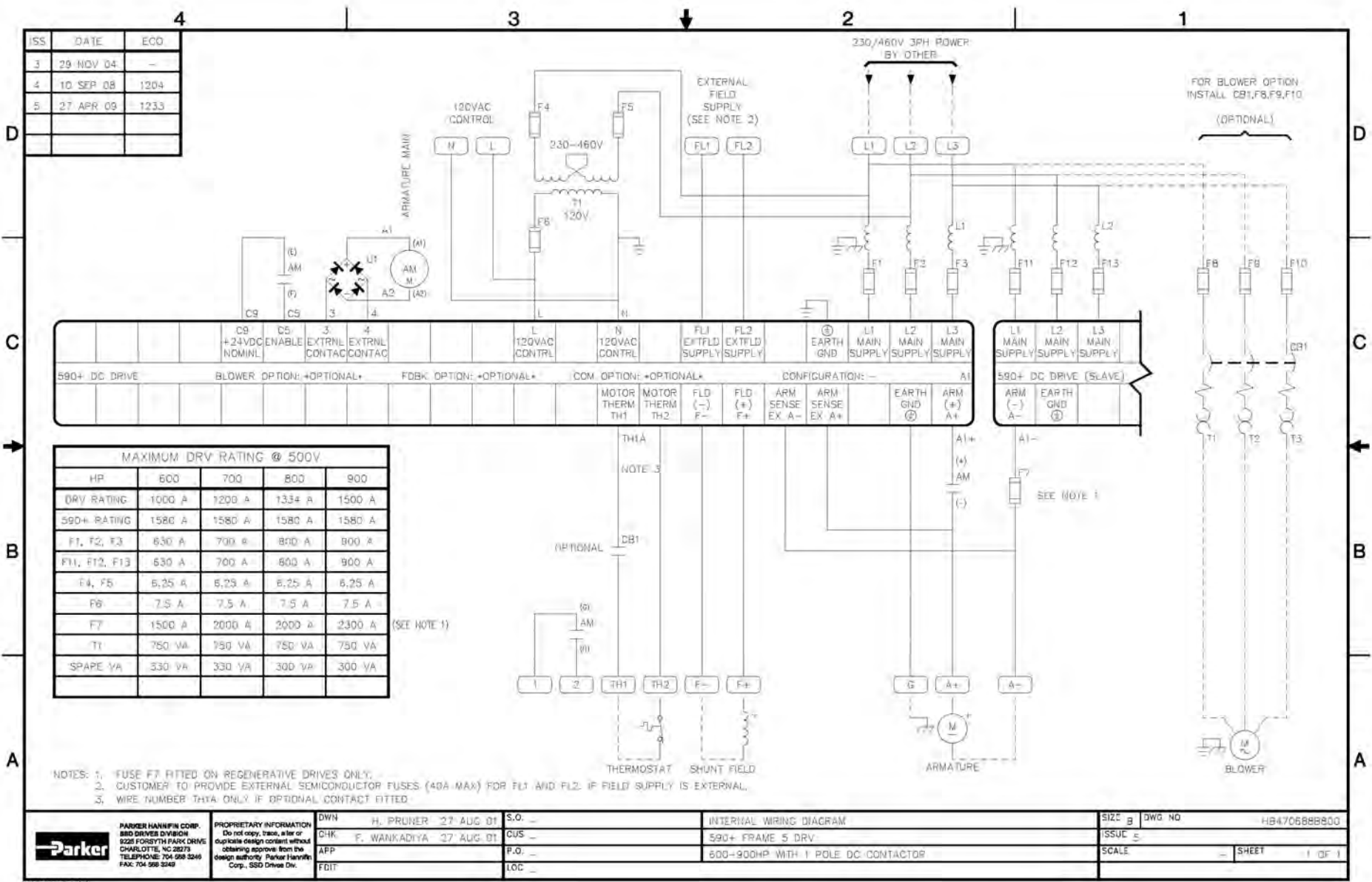
<p>PARKER HANNIFIN CORP. SSD DRIVES DIVISION 9225 FORSYTH PARK DRIVE CHARLOTTE, NC 28273 TELEPHONE: 704-588-3246 FAX: 704-588-3248</p>	<p>PROPRIETARY INFORMATION Do not copy, trace, alter or duplicate design content without obtaining approval from the design authority Parker Hannifin Corp., SSD Drives Div.</p>	<p>DWN H. PRUNER 27 AUG 01 S.O. -</p> <p>CHK F. WANKADIYA 27 AUG 01 CUS -</p> <p>APP F. WANKADIYA 27 MAY 05 P.O. -</p> <p>EDIT LOC -</p>	<p>INTERNAL WIRING DIAGRAM</p> <p>590+ FRAME 4 DRV</p> <p>250 &amp; ++300 HP WITH 3 POLE DC CONTACTOR</p>	<p>SIZE B DWG NO HB470688B250</p> <p>ISSUE 7</p> <p>SCALE - SHEET 1 OF 1</p>
--	--	--	---	--

**Frame 4 DRV : 250 - 300 HP with 3 Pole DC Contactor - Minimum Connection Diagram ( 'general purpose' configuration)**

# 3-84 Installing the Drive



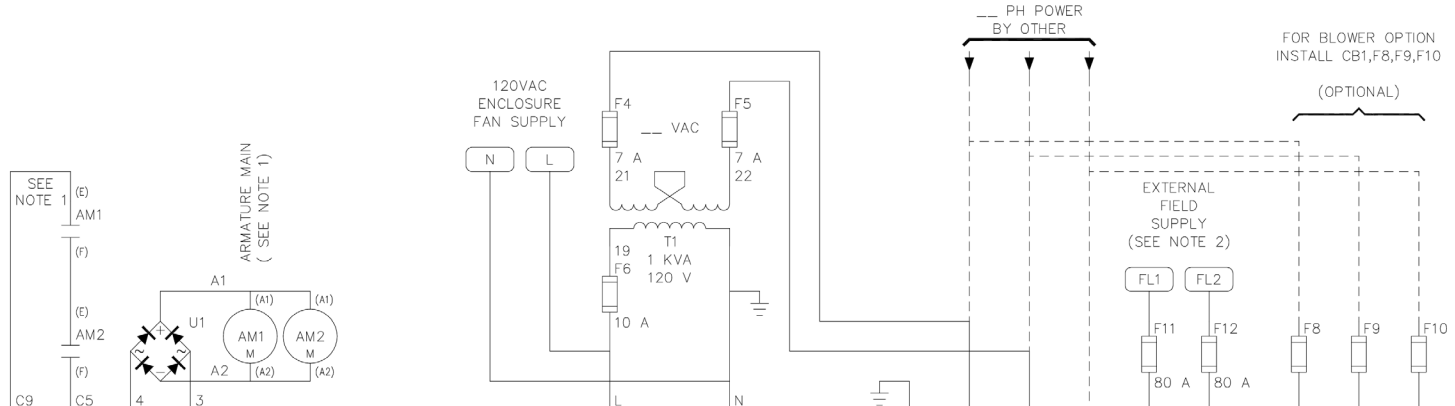
**Frame 4 DRV : 300 - 500 HP with 1 Pole DC Contactor - Minimum Connection Diagram (‘general purpose’ configuration)**



Frame 5 DRV : 600-900 HP with 1 Pole DC Contactor - Minimum Connection Diagram ( 'general purpose' configuration)

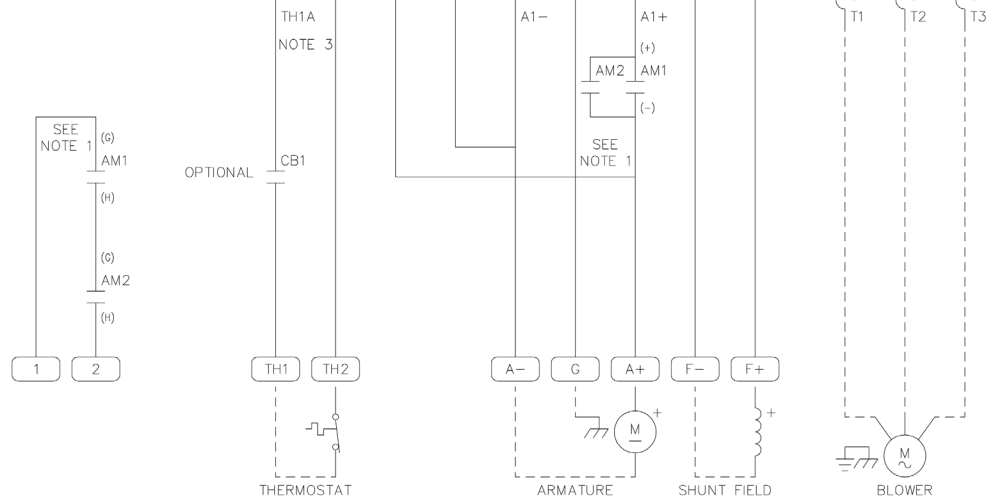
# 3-86 Installing the Drive

ISS	DATE	ECO
A	14 MAR 08	-
B	11 SEP 08	1204



C9	C5	4	3	L	N	EARTH	L1	L2	L3	FL1	FL2	
+24VDC	ENABLE	COIL	COIL	120VAC	120VAC	GND	MAIN	MAIN	MAIN	EXTFLD	EXTFLD	
NOMINL		(L)	(N)	CONTRL	CONTRL		SUPPLY	SUPPLY	SUPPLY	SUPPLY	SUPPLY	
590+	DC DRIVE	BLOWER OPTION: *OPTIONAL*		FDBK OPTION: *OPTIONAL*	COM OPTION: *OPTIONAL*	CONFIGURATION: -	A1					
				MOTOR	MOTOR	ARM	ARM	ARM	EARTH	ARM	FLD	FLD
				TH1	TH2	SENSE	SENSE	SENSE	GND	(+)	(-)	(+)
						MA+	MA-	A-		A+	F-	F+

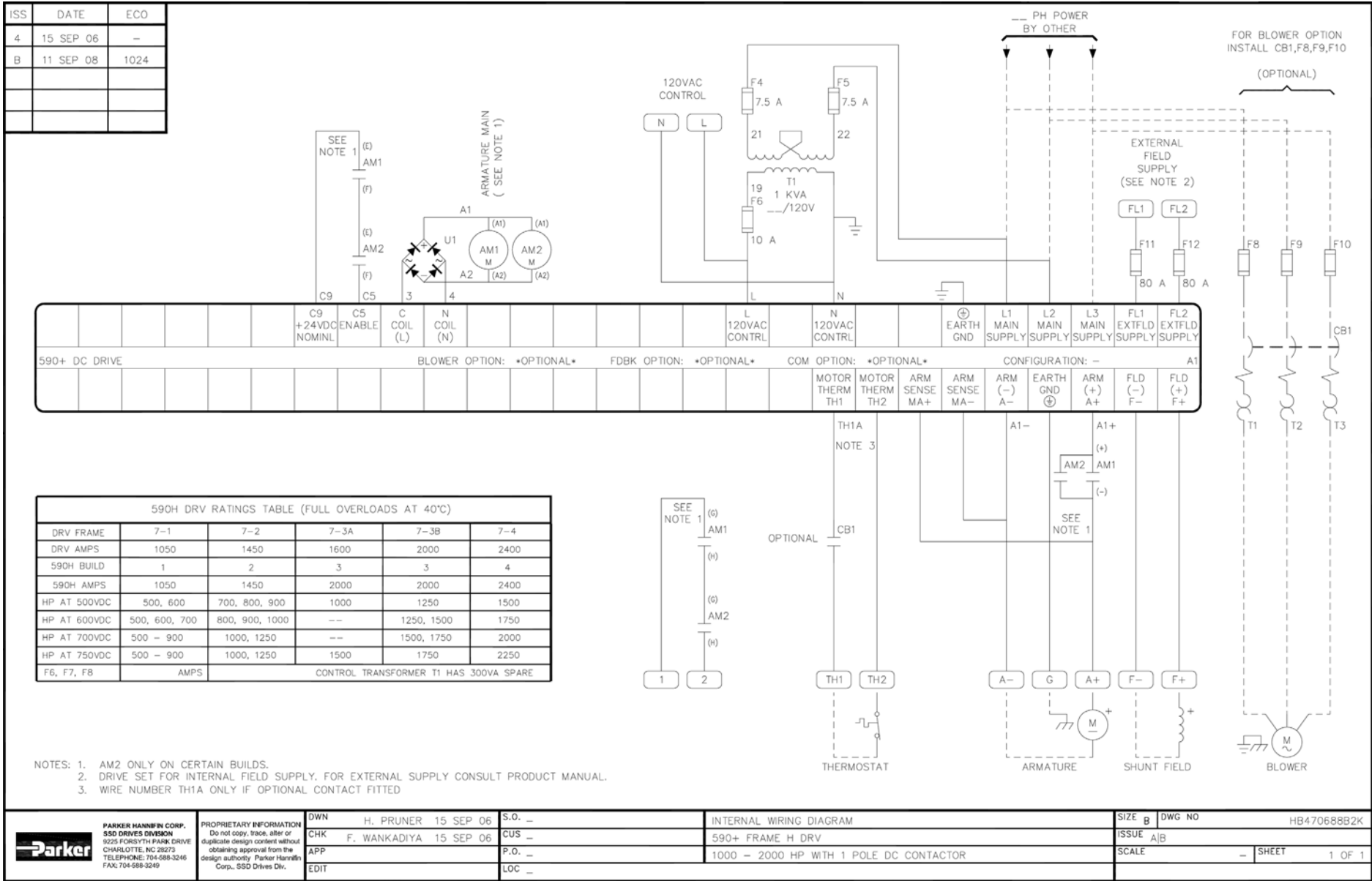
MAXIMUM DRV RATING @ 500V				
HP	700	1000	1200	-
DRV RATING	1200 A	1600 A	1950 A	
590+ RATING	1250 A	1600 A	1950 A	



- NOTES: 1. AM2 ONLY ON CERTAIN BUILDS.  
 2. DRIVE SET FOR INTERNAL FIELD SUPPLY. FOR EXTERNAL SUPPLY CONSULT PRODUCT MANUAL.  
 3. WIRE NUMBER TH1A ONLY IF OPTIONAL CONTACT FITTED

	PARKER HANNIFIN CORP. SSD DRIVES DIVISION 9225 FORSYTH PARK DRIVE CHARLOTTE, NC 28273 TELEPHONE: 704-586-3248 FAX: 704-586-3249	PROPRIETARY INFORMATION Do not copy, trace, alter or duplicate design content without obtaining approval from the design authority Parker Hannifin Corp., SSD Drives Div.	DWN H. PRUNER 13 MAR 08 S.O. - CHK F. WANKADIYA 13 MAR 08 CUS - APP P.O. - EDIT LOC -	INTERNAL WIRING DIAGRAM 590+ FRAME 6 DRV 700-1200 HP WITH 1 POLE DC CONTACTOR	SIZE B DWG NO HB470688B1200 ISSUE B SCALE - SHEET 1 OF 1
--	--	--	--	---	--

**Frame 6 DRV : 700 - 1200 HP with 1 Pole DC Contactor - Minimum Connection Diagram (‘general purpose’ configuration)**



**Frame 7 DRV : 1000 - 2000 HP with 1 Pole DC Contactor - Minimum Connection Diagram (‘general purpose’ configuration)**



# Chapter 4 Calibration and Start-Up

Calibrate and Autotune the drive.

## Introduction

### Initial Checks

#### Recommended Tools

- Check Motor
- Check Supply

### Calibrate the Drive

#### Initial Drive Start

- Tune the Current Loop (AUTOTUNE)
- Set Up Field Control
- Set Up Speed Feedback
- Setup For Field Weakening
- Adjust Speed Loop
- Other Important Parameters

### Recording Parameters

### Starting and Stopping Methods

- Stopping Methods

Normal Stop (C3)

Program Stop (B8)

Coast Stop (B9)

Standstill

The Trip Condition

- Normal Starting Method
- Advanced Starting Methods

Starting Several Drives Simultaneously

Jog

Crawl

Take Up Slack

### External Control of the Drive

Remote Sequencing Command

- Sequence Status





# Introduction

The DC590+ DRV Digital drive is shipped with a default configuration designed to control a shunt or permanent magnet field DC motor. You can adjust the drive's parameters or change its configuration to achieve optimum performance and perform specific control applications.

The drive can be tuned or configured using the drive's keypad, or by using a computer running the software package DSELite. This chapter guides the user through the start up procedure using the keypad.

Follow these procedures only *after* installing and wiring your DC590+ DRV Digital drive (refer to Chapter 3). Review Chapter 6 to become familiar with the keypad before proceeding.

When an instruction refers to a keypad procedure, the menu levels are shown as a path with double colons “::” separating each lower menu level, for example, the parameter RAMP ACCEL TIME is shown as:

SETUP PARAMETERS::RAMPS::RAMP ACCEL TIME

# Initial Checks

## Recommended Tools

### **WARNING**

**This equipment can endanger life through rotating machinery and high voltages. Confirm that all wiring connections are correct before attempting start up procedures.**

Equipment recommended to set up your DC590+ DRV Digital drive and tune a motor include:

- IBM compatible PC with Microsoft Windows™ 3.0 or greater to run DSELite
- Oscilloscope to monitor armature current waveform and speed feedback
- Voltmeter to monitor motor armature and field voltage and check control signal levels
- Ohmmeter to check signal continuity
- Clamp-on, Hall effect ammeter to measure armature and field currents
- Digital hand tachometer to check line or motor speed

## 4-2 Calibration and Start-Up

### Check Motor

#### WARNING

**Disconnect or isolate motor connections from the controller before performing any megger insulation, or high voltage tests on the motor windings.**

After wiring and installing the DC590+ DRV Digital drive, make these motor checks *before* applying power.

- Check and record motor nameplate information for future reference.
- Verify that the motor wiring agrees with the motor installation drawings, if available. Be sure to check the motor field wiring. Some motors have two winding fields that require a series or parallel connection depending on the supply and torque requirements.
- Use an ohmmeter to check insulation and continuity on the motor's armature and field. Use the following as a guide for measuring continuity and resistance through the armature and field:

Armature resistance < 1 ohm (about 3 ohms for motors rated under 10 HP).

Field resistance = Motor nameplate field voltage ÷ Motor nameplate field current

Insulation checks help ensure that there are no shorts in the motor. Use an ohmmeter set to its highest setting and measure the resistance between each conductor and ground. All readings should be greater than 10 M ohms. If available, use a megger to check for insulation faults in the motor armature and field windings.

### Check Supply

#### WARNING

**Measure and verify the power supply to the drive before applying power to the input of the drive.**

1. Measure each leg of the three-phase power supply to ensure they are within  $\pm 10\%$  of motor supply requirements. The controller has multiple ratings. Check whether the supply is suitable to attain the maximum desired armature voltage. Generally, the maximum armature voltage for a three-phase DC drive is 110% of the AC supply voltage. A 240 VDC armature motor requires a 230 VAC supply; 500 VDC motor needs a 480 VAC supply. Consult the factory for other ratings.
2. If a frequency meter is available, measure the incoming line frequency. The frequency should be within the acceptable range of 40 to 70 Hz.
3. Verify that the auxiliary supply voltage is correct at 120 VAC.
  - a. Frame 1 and 2 DRVs require external auxiliary supplies connected to terminals L and N. These drives may include an optional internal control transformer. For them, ensure the transformer taps are set for the supply voltage.
  - b. Frame 3 and larger DRVs include an internal control transformer. For these drives, ensure the transformer taps are set for the supply voltage.


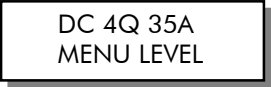





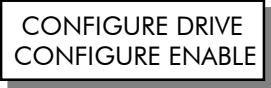



4. Connect power but do *not* start the drive. The drive should now receive control power and the keypad display should read DC 4Q 35A::MENU LEVEL (the DC 4Q 35A line may vary depending on your drive).
5. Check that the motor is free to rotate.

## Calibrate the Drive










Go to the Configure Drive menu to enter the motor calibration data. This is also a good time to enter other commonly used parameter data.

### NOTE

To change any parameter in the procedure below, press the M key to access the parameter and then use the arrow keys to change the setting. When finished, press the E key. At that point you can move to the next parameter.

Press	Keypad Display	Description
		The DC 4Q 35A line may vary depending on your drive. This is the top of the menu tree.
		You are now viewing the level 1 menu headings.
		You have navigated to the CONFIGURE DRIVE menu at level 1.  The CONFIGURE ENABLE parameter contained in this menu allows the calibration settings to be edited (parameters marked with an asterisk (*) in this table). Other parameters in this table can be changed at any time.
		This is the CONFIGURE ENABLE parameter. Press  again to edit the parameter.  Press  to select ENABLED.  All of the LEDs on the display will flash to indicate the drive is in Configuration mode. The drive will not run until CONFIGURE ENABLE is set back to DISABLED.  Press  to exit.

## 4-4 Calibration and Start-Up

Press	Keypad Display	Description
		Now navigate to the following parameters and use the <b>M</b> , <b>▲</b> , <b>▼</b> and <b>E</b> keys, as above, to enter your values.
	CONFIGURE DRIVE NOM MOTOR VOLTS	* Enter the motor nameplate voltage
	CONFIGURE DRIVE ARMATURE CURRENT	* Enter the motor nameplate armature current
	CONFIGURE DRIVE FIELD CURRENT	* Enter the motor nameplate field current
	CONFIGURE DRIVE FLD. CTRL MODE	Verify set to VOLTAGE CONTROL
	CONFIGURE DRIVE FLD. VOLTS RATIO	Calculate and enter ratio where $\text{FLD. VOLTS RATIO} = (\text{Motor Nameplate Field Volts} \div \text{AC Supply}) \times 100$ For example, 300 VDC $\div$ 460 VAC $\times$ 100 = 65%
	CONFIGURE DRIVE SPEED FBK SELECT	Verify set to ARMATURE VOLTS when first installing the drive
	CONFIGURE DRIVE ENCODER LINES	- Skip if not using an encoder - Enter the encoder pulses per revolution (PPR) rating
	CONFIGURE DRIVE ENCODER RPM	- Skip if not using an encoder - Enter the process maximum speed; corresponds to 100% speed
	CONFIGURE DRIVE CONFIGURE ENABLE	Set to DISABLED. The drive will start calibrating, indicated by the display: CONFIGURE DRIVE::CALIBRATING

# Initial Drive Start

---

## **WARNING!**

**Before starting the drive for the first time, make sure that your motor is uncoupled from the load, or ensure that the motor load can move without causing mechanical damage or danger to personnel.**

Now start the drive using the keypad in local mode. This eliminates the configuration but uses the safety interlocks and allows the user to check the feedback polarity, motor speed, motor rotation, etc. The drive will not Autotune if it can't run the motor.

1. Press the L/R key to switch to Local Mode. The SEQ and REF LEDs on the keypad will be ON.
2. Use the arrow keys to set REF: to 0.00%.
3. Press the Start key, the motor will start but will not turn.
4. Use meter to check the field volts. The meter should read the calibrated value for field volts which should match the motor nameplate.

## **Motor Rotation Check**

1. Use the arrow keys to increase REF: to 10%. The motor will rotate at that speed.
2. Observe the motor direction.

If the motor does not turn at all, check that you have proper connections to terminals A6 (CURRENT LIMIT), B8 (PROGRAM STOP), B9 (COAST STOP), and C5 (ENABLE). Each of these signals can be monitored in the DIAGNOSTICS menu on the keypad. Missing any of these will prevent the drive from starting or running.


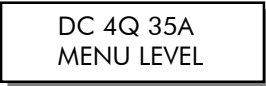





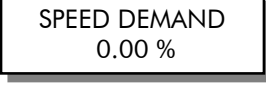
Did the motor run in the wrong direction? If yes, the field polarity is incorrect. Stop the drive, disconnect all power supplies and external field supply (if used) and reverse the field connections (F+ and F-).




3. Use a meter to check armature volts. The meter should read 10% of the calibrated value (for example, 50 VDC for a 500 VDC motor).

Monitor DIAGNOSTIC::CURRENT FEEDBACK. If CURRENT FEEDBACK still reads 0.00%, turn the power off and check the armature connections. If the problem persists, refer to Chapter 7 for detailed troubleshooting information.

## 4-6 Calibration and Start-Up

4. Press the PROG key to display the drive menu. Go to the DIAGNOSTICS menu (see the following procedure).

Press	Keypad Display	Description
		The DC 4Q 35A line may vary depending on your drive. This is the top of the menu tree.
		You are now viewing the level 1 menu headings.
		This is the SPEED DEMAND parameter.
		You are monitoring the SPEED DEMAND parameter.

Now navigate to the other diagnostic parameters in this menu, using the   keys, to monitor speed, terminal volts, field volts, etc. Press  to exit.

**NOTE** The speed feedback will be calibrated later in this start-up procedure.

5. **Skip this step if there are no speed feedback devices on the motor.** Reconnect the power and start the drive. This verifies that the speed feedback device is wired and functioning properly.
- For motors fitted with analog **DC tachometer generators**, monitor DIAGNOSTICS::TACH INPUT.
    - If the reading is about 0.00%, the drive isn't getting a feedback signal. Stop the drive, disconnect all power supplies and check the tachometer generator wiring, connections, feedback card, etc.
    - If the reading is negative, stop the drive, disconnect all power supplies and reverse the tachometer generator wires.
    - If the reading is not near 10.00%, stop the drive, disconnect all power supplies and verify the calibration settings. Calculate the voltage at maximum speed using the following formula. Remember to convert the voltage rating of the tachometer generator to Volts per RPM; for example, 50V/1000 RPM = 0.05V per RPM.

$$\text{Maximum DC Voltage} = \text{Volts per RPM} \times \text{Maximum Desired RPM}$$

- b. For motors fitted **AC tachometer generators**, monitor DIAGNOSTICS::TACH INPUT:
- If the reading is about 0.00%, the drive isn't getting a feedback signal. Stop the drive, disconnect all power supplies and check the tachometer generator wiring, connections, feedback card, etc.
  - If the reading is not near 10.00%, stop the drive, disconnect all power supplies and verify the calibration settings. Calculate the voltage at maximum speed using the following formula. Remember to convert the voltage rating of the tachometer generator to Volts per RPM; for example, 50V/1000 RPM = 0.05V per RPM.

$$\text{Maximum AC Voltage} = \text{Volts per RPM} \times \text{Maximum Desired RPM} \times 1.3$$

---

### Caution

A runaway condition can exist when using an AC tachometer generator on a regenerative model DC590+ DRV, even if the speed reference is always positive. To avoid this problem, use a non-regenerative drive on a motor with an AC tachometer generator. If using a regenerative DC590+ DRV Digital drive set minimum demand to 0% under SETUP PARAMETERS::SPEED LOOP::MIN DEMAND.

---

- c. For motors fitted with **5701/5901 Microtachs** or **wire-ended electrical encoders**, monitor DIAGNOSTICS::ENCODER..
- If the reading is about 0 RPM, the drive isn't getting a feedback signal. Stop the drive, disconnect all power supplies and check the encoder wiring, connections, feedback card, etc.
  - If the reading is negative, stop the drive and change the feedback sign by setting SETUP PARAMETERS::SPEED LOOP::ENCODER SIGN to POSITIVE or NEGATIVE as required.
  - If the reading is not near 10% of the base RPM (for example 175 RPM for a 1750 RPM motor), stop the drive and verify the calibration settings.

---

### Caution

When changing set up parameters (such as feedback polarity), be certain to save the change before disconnecting control power or the set up will be lost.

---

6. If the drive is regenerative and the application requires reverse rotation, provide a negative speed demand, start the drive and verify that the motor runs in the reverse direction.
7. Stop the drive then SAVE PARAMETERS.

**NOTE** At this stage, you have successfully run the motor and verified the speed feedback devices are functioning correctly.



## 4-8 Calibration and Start-Up

# Tune the Current Loop (AUTOTUNE)

---

### Caution

This is an essential step in setting up your DC590+ DRV Digital drive and *should not* be overlooked.

---

The AUTOTUNE function tunes the current loop automatically and sets the proportional gain, integral gain, and the discontinuous/continuous breakpoint for optimum drive response for a given motor. The drive cannot achieve peak performance without properly setting these parameters. Perform a complete AUTOTUNE procedure at least once with each controller/motor combination or if the motor armature or field windings have been rewound.

### NOTE

**AUTOTUNE may not work on motors with either very long or very short time constants (for example, very short time constant permanent magnet motors). In these instances the current loop must be tuned manually. Contact Parker SSD Drives Customer Service for assistance.**

### WARNING









**When clamping the motor, you must use a clamping force equal to or greater than the motor torque rating.**

AUTOTUNE can be used for shunt wound, compound wound, and permanent magnet motors. The shaft on compound-wound and permanent magnet motors must be locked for AUTOTUNE to work. For shunt wound motors, the shaft may need to be clamped if a residual field causes the motor to rotate during AUTOTUNE. Any rotation of the motor during the AUTOTUNE procedure causes AUTOTUNE to abort.

### WARNING

**Make sure it is safe to power and turn the motor and that operation of the motor and the drive will not pose a danger to personnel or equipment.**

1. Turn on the main supply power.
2. Set AUTOTUNE to ARMATURE (see the following procedure).

Press	Keypad Display	Description
	DC 4Q 35A MENU LEVEL	The DC 4Q 35A line may vary depending on your drive. This is the top of the menu tree.
	MENU LEVEL DIAGNOSTICS	You are now viewing the level 1 menu headings.
	MENU LEVEL CONFIGURE DRIVE	You have navigated to the CONFIGURE DRIVE menu at level 1.
	CONFIGURE DRIVE CONFIGURE ENABLE	This is the CONFIGURE DRIVE menu.
	CONFIGURE DRIVE AUTOTUNE	Navigate to the AUTOTUNE parameter by repeatedly pressing the  key. Press  to edit the parameter. Press  to select ARMATURE.

3. Start the drive using the keypad.
4. At this point, the drive performs the AUTOTUNE function automatically, setting the following parameters:
  - a. SETUP PARAMETERS::CURRENT LOOP::PROP. GAIN
  - b. SETUP PARAMETERS::CURRENT LOOP::INT. GAIN
  - c. SETUP PARAMETERS::CURRENT LOOP::DISCONTINUOUS

These parameters give optimum performance of the current loop and should *not* be adjusted outside the AUTOTUNE algorithm.
5. Once AUTOTUNE is finished, the main contactor will open automatically, signaling the end of the procedure. The controller returns to a safe, stopped condition.
 

**Note:** If the AUTOTUNE is interrupted for any reason, either due to an alarm like the motor rotates over 10% speed during the procedure or removing the RUN or ENABLE signals, AUTOTUNE ceases automatically. The armature current is disabled, the main contactor opens, and the AUTOTUNE parameter is reset to OFF. To retry the procedure, first clear any faults.
6. Remove the clamp, if fitted, from the motor.
7. SAVE PARAMETERS when finished.

## 4-10 Calibration and Start-Up

### Armature Current Waveform Check

Because there is no field voltage, the drive conducts full load current through the armature during an AUTOTUNE. You can monitor the armature current waveform with an oscilloscope to verify correct operation of the controller. Attach the oscilloscope leads to the Armature Current test point and the Sig. Ground test point. Refer to Chapter 7: Test Points for the drive's test point locations. At full rated current, the armature current signal (IA) should average 1.0 volts since 1.0 volts equals 100% current. There should be six current pulses per mains cycle at all times. The pulses should be uniformly shaped and evenly spaced, each with a width of 2.8 mS on 60 Hertz supplies, and 3.3 mS on 50 Hertz supplies.

### Set Up Field Control





**NOTE** If the drive is controlling a permanent magnet motor, set **FIELD ENABLE** to **DISABLED** and skip this section.












At this point, the drive/motor combination is operating in field voltage control. This section lists the procedure for setting up for Voltage or Current control. For best performance, set the field to Current control.

1. Give a 0% speed demand to the drive.
2. Start the drive. Measure the field voltage with a DC voltmeter and verify that it matches the motor nameplate rating. Measure the motor field current with a Hall effect current meter or a current shunt. If the motor field voltage or current is incorrect, follow the steps below to set in the correct field supply.

#### WARNING

**Failure to set up the field supply correctly can cause dangerous overspeed conditions resulting in serious equipment damage or injury to personnel. Do not continue the start up procedure until the DC field supply is within its required rating.**

Press	Keypad Display	Description
	DC 4Q 35A MENU LEVEL	The DC 4Q 35A line may vary depending on your drive. This is the top of the menu tree.
	MENU LEVEL DIAGNOSTICS	You are now viewing the level 1 menu headings.
	MENU LEVEL CONFIGURE DRIVE	You have navigated to the CONFIGURE DRIVE menu at level 1.
	CONFIGURE DRIVE CONFIGURE ENABLE	This is the CONFIGURE DRIVE menu.

Press	Keypad Display	Description
	<div style="border: 1px solid black; padding: 5px; width: fit-content; margin: 0 auto;">                     CONFIGURE DRIVE FLD. CTRL MODE                 </div>	Navigate to the FLD. CTRL MODE parameter by repeatedly pressing the  key. Press  to edit the parameter. Verify this is set to VOLTAGE CONTROL or CURRENT CONTROL. Press  or  to select. Press  to exit.
Now navigate to the following parameter and use the  ,  ,  and  keys, as above, to enter your value.		
	<div style="border: 1px solid black; padding: 5px; width: fit-content; margin: 0 auto;">                     CONFIGURE DRIVE FLD. VOLTS RATIO                 </div>	- Skip if in Field Current mode - Calculate and enter ratio where $\text{FLD. VOLTS RATIO} = (\text{Motor Nameplate Field Volts} \div \text{AC Supply}) \times 100$ For example, $300 \text{ VDC} \div 460 \text{ VAC} \times 100 = 65\%$

### Field Voltage Control:

- a. Measure the field voltage on terminals F- and F+ and verify that it equals the motor nameplate rating.
- b. Adjust CONFIGURE DRIVE::FLD. VOLTS RATIO until the voltage equals field voltage rating on the motor nameplate label.

**NOTE** The DC motor field impedance increases with temperature, therefore the field current of a motor in voltage control can read higher than the nameplate rating when the field is initially powered. The current should fall to its nominal value as the motor warms up.

### Field Current Control:

**NOTE** FLD CTRL MODE IS must be set to CURRENT CONTROL when operating the motor in field weakening mode.











- a. Measure the motor field current if a Hall effect current meter and adjust SETUP PARAMETERS::CALIBRATION::FIELD I CAL until the measured field current equals the field current rating on the motor nameplate label.
3. Stop the drive.
4. If any changes were made to the drive's parameters settings, PARAMETER SAVE.

## 4-12 Calibration and Start-Up

### Set Up Speed Feedback

At this point, the drive/motor combination is operating in armature voltage control. The other speed feedback devices were checked and functioning properly. This section lists the procedure for setting up tachometer generator or encoder speed feedback.

1. Set SPEED FBK SELECT to the proper selection (see the following procedure).

Press	Keypad Display	Description
	DC 4Q 35A MENU LEVEL	The DC 4Q 35A line may vary depending on your drive. This is the top of the menu tree.
	MENU LEVEL DIAGNOSTICS	You are now viewing the level 1 menu headings.
	MENU LEVEL CONFIGURE DRIVE	You have navigated to the CONFIGURE DRIVE menu at level 1.
	CONFIGURE DRIVE CONFIGURE ENABLE	This is the CONFIGURE DRIVE menu.
	CONFIGURE DRIVE SPEED FBK SELECT	Navigate to the SPEED FBK SELECT parameter by repeatedly pressing the  key. Press  to edit the parameter. Press  or  to select ARM VOLTS FBK, ANALOG TACH or ENCODER. Press  to exit.

2. Start the drive; gradually increase the speed demand signal to 50% and monitor DIAGNOSTICS::TERMINAL VOLTS. Measure the armature voltage on the drive output with a DC voltmeter. TERMINAL VOLTS should read within 10% of the measured value. For example, when measuring armature volts at terminals A+ and A- with a voltmeter, a 500 VDC armature should read 250 VDC at 50% speed demand and TERMINAL VOLTS should be within 45 to 55%. If the reading is outside this range, check the drive's voltage calibration before continuing.

Increase the speed demand to 100% and check the shaft speed accuracy with a hand tachometer. Measure the armature voltage. If fine adjustment is needed, adjust the drive's calibration according to the speed feedback selection.

3. ARMATURE VOLTAGE FEEDBACK

Armature voltage feedback uses the motor's back EMF as speed feedback and is the drive's default feedback setting. It requires no feedback device, isolator or additional external connections. The scaling parameter, SETUP PARAMETERS::CALIBRATION::ARMATURE V CAL, fine

tunes the drive's armature voltage calibration and has a range of 1.1000 to 0.9800, corresponding to -10% to +2% trim. Changes outside this range require re-calibration as described earlier in this Chapter.

### IR COMPENSATION SETUP

Properly setting the PARAMETERS::CALIBRATION::IR COMPENSATION parameter, or motor loss compensation, improves the speed accuracy when running in armature voltage feedback.

- Run the motor without a load. Monitor the actual speed with a hand tachometer.
- With the same speed setpoint, run the motor at full load and monitor the actual speed again with a hand tachometer.
- Adjust IR COMPENSATION until the full load speed is the same as the no load speed.

**NOTE** Too much IR COMPENSATION causes instability.

### 4. MICROTACH or WIRE-ENDED ELECTRICAL ENCODERS

- You can monitor the encoder speed under DIAGNOSTICS::ENCODER in the keypad.
- Either encoder gives rotational speed for which adjustment is unnecessary; however, the process may require an accurately set speed calibration. If required, adjust the calibration parameter CONFIGURE DRIVE::ENCODER RPM to match the motor rotational speed to the roll speed with a hand tachometer. Speed match the motor through the ratio calculation:

$$\text{New ENCODER RPM Setting} = \text{Present ENCODER RPM Setting} \times \text{Desired RPM} \div \text{Measured RPM}$$

### 5. AC/DC ANALOG TACHOMETER GENERATOR

- Settings on the analog tachometer generator feedback option card give a coarse scaling of the analog tachometer generator feedback voltage. Fine-tune the feedback by adjusting drive software parameters.

**NOTE** The option card settings for AC tachometer generators are  $1.3 \times$  Calculated Value.

Use a hand tachometer to measure the motor speed and adjust SETUP PARAMETERS::CALIBRATION::ANALOG TACH CAL to scale the overall feedback. Speed match the motor through the ratio calculation:

$$\text{New ANALOG TACH CAL Setting} = \text{Present ANALOG TACH CAL Setting} \times \text{Desired RPM} \div \text{Measured RPM}$$

The gain range varies from 1.1000 to 0.9800, or -10% to +2% trim. Changes outside this range require a re-calibration of the feedback calibration card as described earlier in this chapter.

If a tachometer's observed operation is within its rated accuracy, adjustment is not recommended and will complicate speed calibration.

6. SAVE PARAMETERS when finished.

## 4-14 Calibration and Start-Up

### Setup For Field Weakening

If the motor requires field weakening to achieve top speed, follow these steps.

**NOTE** Field weakening requires tachometer generator, or wire-ended or Microtach encoder speed feedback.

1. Verify that the field current calibration is set as described earlier in this chapter. Many field weakened motor list the field current as two values, a minimum and a maximum, indicating the field weakened range of the motor. Calibrate the motor field for the larger of these two values.

1b. and verify the field is enabled by monitoring parameter SETUP PARAMETERS::FIELD CONTROL::FIELD ENABLE.

2. Set the following parameters as listed below.

SETUP PARAMETERS::FIELD CONTROL::FIELD CTRL MODE = CURRENT CONTROL

SETUP PARAMETERS::FIELD CONTROL::FLD. CURRENT VARS::FLD. WEAK VARS::FLD. WEAK ENABLE = ENABLED

SETUP PARAMETERS::FIELD CONTROL::FLD CURRENT VARS::FLD. WEAK VARS::MAX VOLTS = 100%

**NOTE** This sets the switchover point where field weakening begins.

3. Ensure that SETUP PARAMETERS::FIELD CONTROL::FLD CURRENT VARS::FLD WEAK VARS::MIN FLD. CURRENT is set correctly for the motor to reach top speed. Calculated MIN FLD. CURRENT using the formula:

$$(\text{Minimum Field Current} \div \text{Maximum Field Current}) \times 90\%$$

This sets MIN FLD. CURRENT 10% lower than the field calculated to reach full speed. The minimum and maximum field currents are found on the motor nameplate label. The 10% cushion should overcome any inaccuracies in the nameplate data.

4. Run the drive up to base speed. Monitor DIAGNOSTICS::TERMINAL VOLTS to verify that the armature voltage is approximately equal to the MAX VOLTS value set in the previous step.
5. While slowly increasing the speed above base speed, monitor TERMINAL VOLTS. It should remain constant. Monitor the FIELD I FBK diagnostic and observe it decrease toward the MIN FLD. CURRENT calculated earlier.

Gradually increase to maximum speed, monitoring TERMINAL VOLTS at maximum speed. If the TERMINAL VOLTS increases or the drive trips on an OVERVOLTS alarm, the MIN FLD. CURRENT setting is too high. Reduce the parameter slightly in order to reach maximum speed. Do not reduce this parameter below 10% or you risk the motor running away.

When using an analog tachometer make fine adjustments to the speed feedback calibration by adjusting SETUP PARAMETERS::CALIBRATION::ANALOG TACH CAL.

6. For regenerative, reversing drives, check the maximum reverse speed. Correct any asymmetry in a reversing drive by adjusting SETUP PARAMETERS::CALIBRATION::ZERO SPD. OFFSET.
7. Stop the drive and SAVE PARAMETERS.

**NOTE** If the standard settings don't provide adequate performance, contact Parker SSD Drives Product Support for information on manually tuning the drive for field weakening.

## Adjust Speed Loop

For most applications, the default values for speed loop parameters SPD.PROP.GAIN and SPD.INT.TIME provide stable performance. In a few cases, you may need to tune the speed loop for optimum speed response. The following procedures explain how to tune the speed loop.

For this procedure, monitor the speed feedback with an oscilloscope between terminals A7 (SPEED FEEDBACK) and A0 (0V).

**NOTE** Adjust the speed loop only after tuning the current loop with AUTOTUNE. Make certain the motor is connected to the load it will normally be running.

- SPD.PROP.GAIN scales the output based upon the input speed error. Increasing SPD.PROP.GAIN improves response time but also increases overshoot.
  - SPD.INT.TIME eliminates steady-state error. Reducing SPD.INT.TIME improves response, but will cause instability if set too short.
1. Connect terminal B3 (+10 VDC) through a switch to terminal A3. This will provide the step change input for verifying speed loop performance.
  2. Calibrate terminal A3 for 10% output by setting SETUP PARAMETERS::SPEED LOOP::SETPOINTS::RATIO 2 (A3) to 0.1000.
  3. Set SETUP PARAMETERS::SPEED LOOP::INT. DEFEAT to ON. This disables the integral gain.
  4. Run the motor at a typical operating speed through the speed ramp input, terminal A4. Do not set the speed above 50 percent.
  5. Check the speed loop performance by making step changes using the switch at terminal A3. Increase SETUP PARAMETERS::SPEED LOOP::PROP. GAIN until the response is critically damped, generally no more than 4% overshoot, as illustrated (refer to Chapter 5).
  6. Once stable, proportional control is attained, set SETUP PARAMETERS::SPEED LOOP::INT. DEFEAT to OFF.
  7. Check the speed loop performance by making step changes using the switch at terminal A3. Reduce SETUP PARAMETERS::SPEED LOOP::SPD.INT.TIME until the response is critically damped.
 

**Note:** The default value for SPD.INT.TIME is 0.5 seconds. That value may be too small for large inertia loads and cause the system to be unstable from the start.
  8. Stop the drive and remove the switched signal from terminal A3.
  9. Set SETUP PARAMETERS::SPEED LOOP::SETPOINTS::RATIO 2 (A3) back to 1.0000, then run normally.
  10. SAVE PARAMETERS prior to disconnecting power.



## 4-16 Calibration and Start-Up

### Other Important Parameters

Other parameters, for example ramp rates, may be important for the process. Different ramp rates are available for various conditions:

Condition	Parameter Name	Menu
Speed Setpoint Change	RAMP ACCEL TIME and RAMP DECEL TIME	RAMPS
Jog Acceleration/Deceleration	RAMP RATE	JOG/SLACK
Controlled Stop Deceleration	STOP TIME	STOP RATES
Fast Stop Deceleration	PROGRAM STOP TIME	STOP RATES
Electronic MOP Control	INCREASE RATE and DECREASE RATE	RAISE/LOWER

Appendix D: "Programming" fully discusses the functionality and scaling of all drive parameters.

### Recording Parameters

It is important to have a backup copy of your drive parameters. This copy might consist of writing down the information on a chart, saving the parameters to a computer disk, or printing the parameters using an external computer.

To save the parameters as either a hexadecimal ASCII file or as a text file ready for printing, connect a computer to the P3 serial port. Use a telecommunications program, such as Windows Terminal™, or other terminal emulation programs. Refer to "Using Microsoft® Windows™ to Document and Clone 590 DRV Digital Drives" for detailed instructions using Windows Terminal™ for uploading and downloading drive parameters. Refer to Appendix A : "Serial Communications" for general information on using the P3 port to upload and download drive parameters.

DSELite is available from <http://www.ssddrives.com/usa/doc/Main%20Software.php>. This software allows you to easily configure, download, and upload the drive parameters using a computer.

# Starting and Stopping Methods

## Stopping Methods

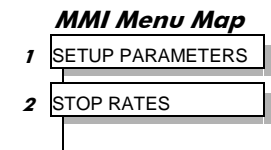
- If the Drive is “non-regenerative” (2-quad - 591+) it effectively coasts to a stop once the current demand reverses.
- If the Drive is “regenerative” (4-quad - 590+) then it can stop faster because it uses energy from the load, i.e. reverse current is allowed to flow.

*Normal Stop and Program Stop are only relevant for a “regenerative” controller.*

*The parameters STOP TIME and PROG STOP TIME have associated timers which initiate a Coast Stop after the timed period.*

*The Coast Stop has direct control of the Run relay with no intervening electronics.*

All associated parameters can be found in the STOP RATES menu.

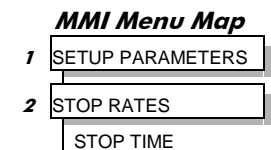


Terminal	Description	Function	Parameter	Priority
B9	Coast Stop	Motor coasts to rest	--	Overrides Program Stop and Normal Stop
B8	Program Stop	Motor decelerates at Program Stop rate	PROG STOP TIME	Overrides Normal Stop
C3	Start/Run (Normal Stop)	Motor decelerates at Normal Stop rate	STOP TIME	--

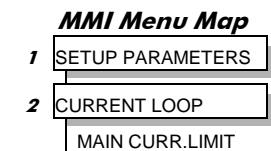
## Normal Stop (C3)

This is achieved by removing 24V from Terminal C3.

The motor speed is brought to zero in a time defined by the STOP TIME parameter.

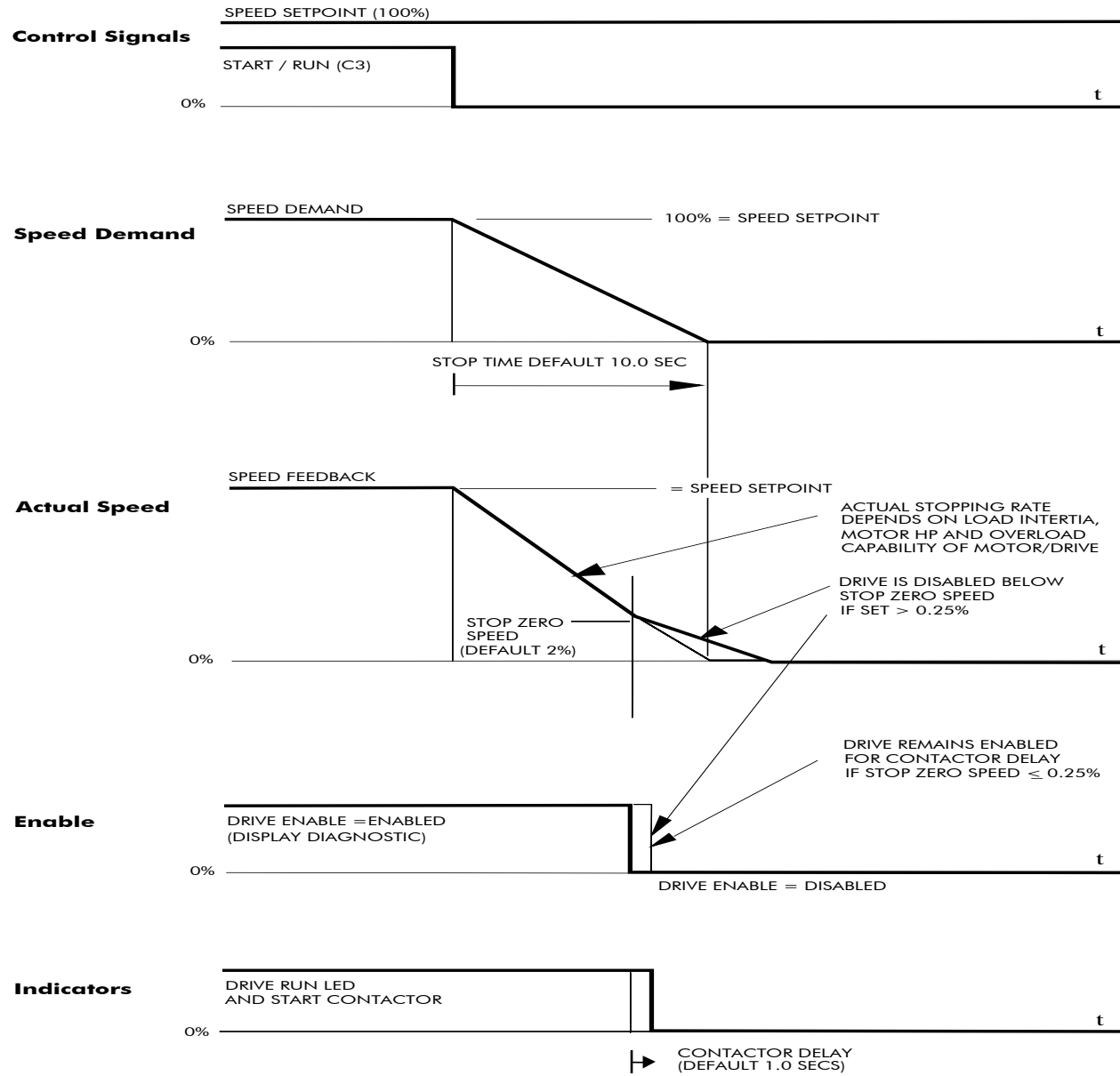


During Normal Stop, the current is limited by the MAIN CURR. LIMIT parameter

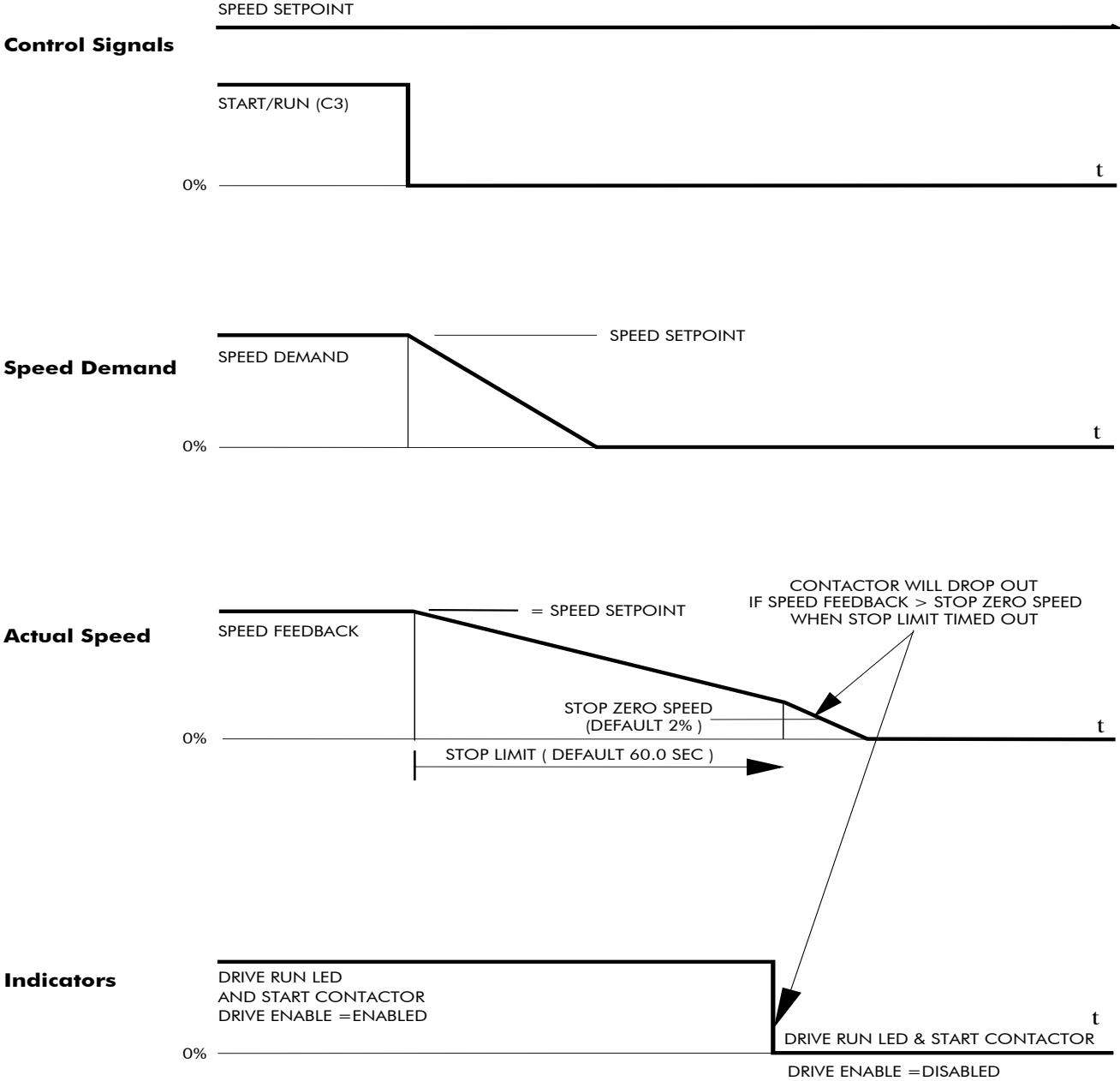


# 4-18 Calibration and Start-Up

## NORMAL STOP



TIME-OUT IN NORMAL STOP



## 4-20 Calibration and Start-Up

### Program Stop (B8)

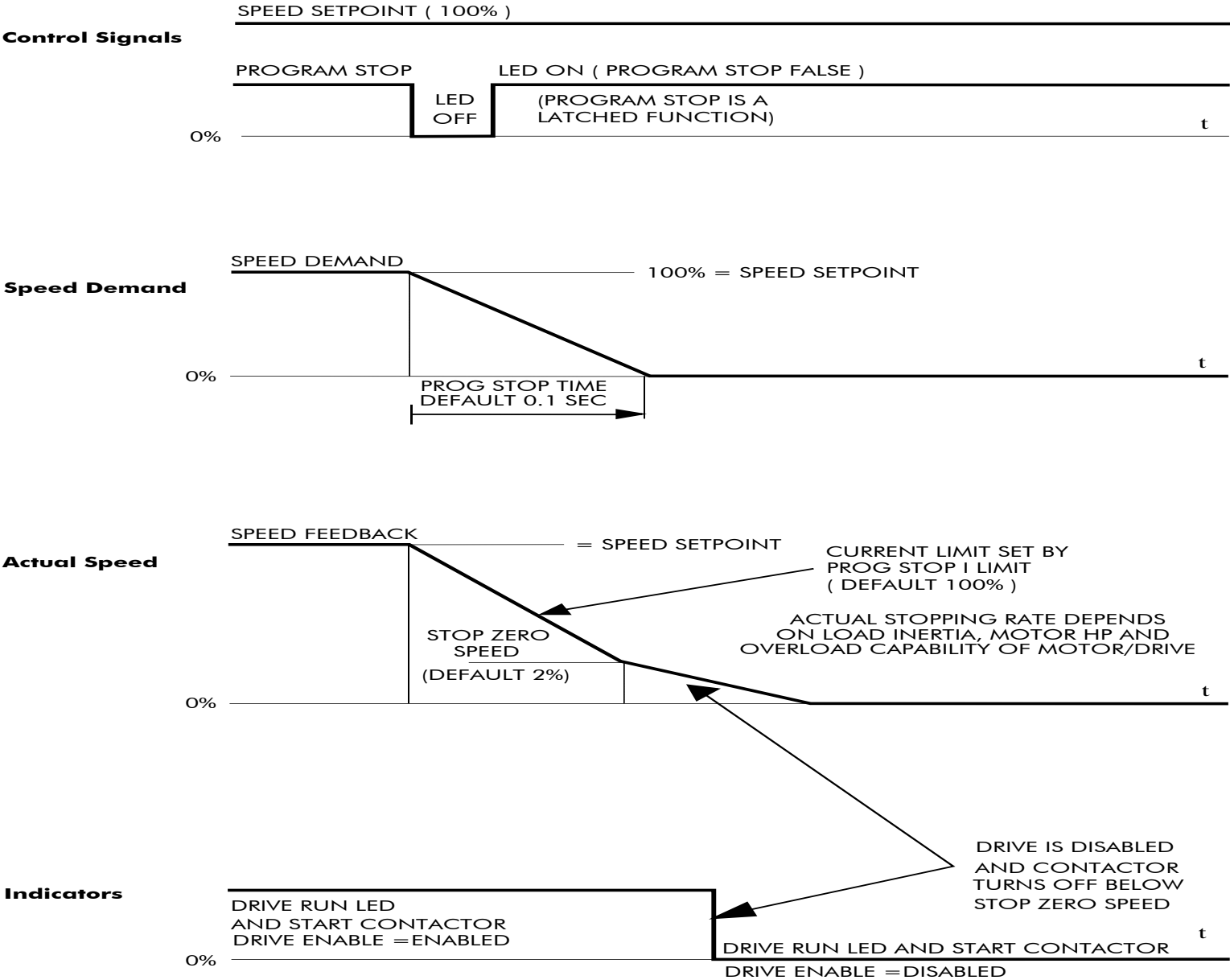
This is achieved by removing 24V from Terminal B8.

The motor speed is brought to zero under conditions defined by the PROG. STOP TIME (ramp rate) and PROG. STOP I LIMIT parameters.

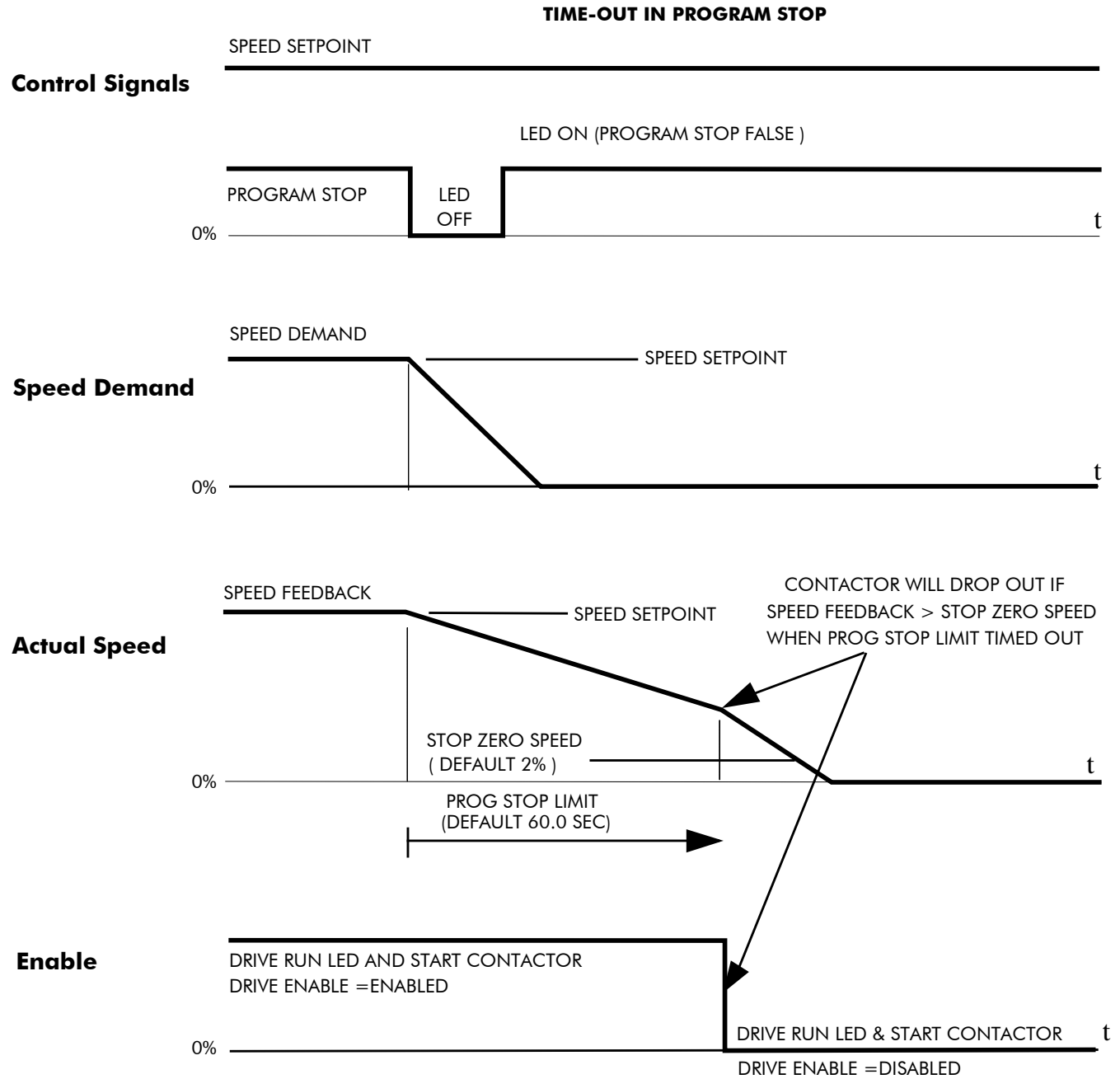
#### ***MMI Menu Map***

- 1 SETUP PARAMETERS
- 2 STOP RATES
  - PROG. STOP TIME
  - PROG. STOP I LIMIT

**PROGRAM STOP TIMING**



# 4-22 Calibration and Start-Up



## Coast Stop (B9)

This is achieved by removing 24V from Terminal B9.

The stack is automatically quenched and the contactor is opened. The motor coasts to a stop.

**NOTE** The motor coast stop rate is dictated by the motor inertia - the drive does not control the motion.

## Standstill

Refer to Appendix D: “Programming” - STANDSTILL.

## The Trip Condition

When a trip condition is detected, a similar stopping method to Coast Stop is used. The power stack cannot be re-enabled until the trip condition has been cleared and successfully reset.

Refer to Chapter 7: “Trips and Fault Finding” for further details.

### MMI Menu Map

1	SETUP PARAMETERS
2	STANDSTILL
	STANDSTILL LOGIC
	ZERO THRESHOLD

## Normal Starting Method

To achieve a normal start of the Drive:

1. Apply 24V to Terminal C5 (Enable)
2. Apply 24V to Terminal C3 (Start)

**NOTE** The Drive will not start if there are alarms present, or if Terminals B8 (Program Stop) or B9 (Coast Stop) are low, 0V.

*Ensure that Program Stop and Coast Stop are valid before Start/Run is applied.*



## 4-24 Calibration and Start-Up

# Advanced Starting Methods

## Starting Several Drives Simultaneously

1. Apply 24V to Terminal C3 (Start)
2. Use Terminal C5 (Enable) to synchronise the start-up of the Drives

## Jog

**NOTE** The Drive will not start if there are alarms present.

This facility provides two dedicated jog setpoints (or perhaps an Inch Forward/Inch Reverse). Activating Jog runs the motor at speeds set by JOG SPEED 1 or JOG SPEED 2. The JOG/SLACK::MODE parameter selects JOG SPEED 1 or 2.

1. Apply 24V to Terminal C5 (Enable)
2. Apply 24V to Terminal C4 (Jog Mode)

Refer to Appendix D: “Programming” - JOG/SLACK for further information. Also refer to the STOP RATES function block: the CONTACTOR DELAY parameter is used to prevent multiple operations of the main contactor from rapid use of the Jog switch.

## Crawl

**NOTE** The Drive will not start if there are alarms present.

This facility provides a dedicated crawl setpoint. Activating Crawl runs the motor at the speed set by CRAWL SPEED.

1. Apply 24V to Terminal C5 (Enable)
2. Set JOG/SLACK::MODE parameter (Tag No. 228) to **TRUE**.
3. Apply 24V to Terminal C3 (Start) and Terminal C4 (Jog Mode) simultaneously to start the Drive using the crawl speed, in Forward or Reverse.

When selecting CRAWL, apply Start (C3) and Jog (C4) simultaneously, otherwise you may experience Modes 3 or 6 momentarily. Refer to Appendix D: “Programming” - JOG/SLACK for further information (see the Setpoint Selection Table).

### MMI Menu Map

1	SETUP PARAMETERS
2	JOG/SLACK
	JOG SPEED 1
	JOG SPEED 2
	TAKE UP 1
	TAKE UP 2
	CRAWL SPEED
	MODE
	RAMP RATE

### MMI Menu Map

1	SETUP PARAMETERS
2	JOG/SLACK
	JOG SPEED 1
	JOG SPEED 2
	TAKE UP 1
	TAKE UP 2
	CRAWL SPEED
	MODE
	RAMP RATE

## Take Up Slack

**NOTE** The Drive will not start if there are alarms present.

This facility provides two additional Take Up Slack setpoints. Activating Take Up Slack runs the motor at the speed set by "speed setpoint + TAKE UP1" or "speed setpoint + TAKE UP 2".

### TAKE UP SLACK 1:

1. Apply 24V to Terminal C5 (Enable).
2. Apply 24V to Terminal C3 (Start) to accelerate to set speed.
3. Set JOG/SLACK::MODE parameter (Tag No. 228) to **FALSE**.
4. Apply 24V to Terminal C4 (Jog Mode) to run the motor at "speed setpoint + TAKE UP 1".
5. Remove 24V from Terminal C4 (Jog Mode) to run the motor at speed setpoint.

### TAKE UP SLACK 2:

6. Apply 24V to Terminal C5 (Enable).
7. Apply 24V to Terminal C3 (Start) to accelerate to set speed.
8. Set JOG/SLACK::MODE parameter (Tag No. 228) to **TRUE** to run the motor at "speed setpoint + TAKE UP 2".
9. Set JOG/SLACK::MODE parameter (Tag No. 228) to **FALSE** to run the motor at speed setpoint .

Refer to Appendix D: “Programming” - JOG/SLACK for further information (see the Setpoint Selection Table).

### MMI Menu Map

1	SETUP PARAMETERS
2	JOG/SLACK
	JOG SPEED 1
	JOG SPEED 2
	TAKE UP 1
	TAKE UP 2
	CRAWL SPEED
	MODE
	RAMP RATE

# External Control of the Drive

## Remote Sequencing Command

**REM. SEQUENCE** : Tag 536, Mnemonic "ow", Default = 0x0000 ("0x" denotes a Hexadecimal value)

This is a control word that allows the device to be operated remotely over a field bus. REM. SEQ. ENABLE must be TRUE to enable this function.

**NOTE** Refer to the RS485 Communications Interface Technical Manual, HA463560U002 on the website, for information about the EI Bisynch ASCII communications protocol.

Reserved bits are undefined when read and should be set Zero when written.

Bit Number	Mask	Name	Comment
0 (lsb)	0x0001	Remote Enable	
1	0x0002	Remote Start	
2	0x0004	Remote Jog	
3	0x0008	Remote Jog Mode	Selects Jog Speed
4	0x0010	Reserved	
5	0x0020	Reserved	
6	0x0040	Reserved	
7	0x0080	Reserved	
8	0x0100	Remote Alarm Ack	Alarm Acknowledge
9	0x0200	Remote/Remote Trip	Remote Trip (High for OK)
10	0x0400	Reserved	
11	0x0800	Reserved	
12	0x1000	Reserved	
13	0x2000	Reserved	
14 (msb)	0x4000	Reserved	
15 (msb)	0x8000	Validation	This bit must be zero for the command word to be accepted

## Useful Commands using EI Bisynch ASCII - REM. SEQUENCE

Tag 536, Mnemonic "ow", for example:

	/Remote Trip	Alarm Ack	Jog Mode	Jog	Start	Enable	Command
Start Drive	1	0	X	0	1	1	ow>0203
Stop Drive	1	0	X	0	0	1	ow>0201
Disable Drive	1	0	X	X	X	0	ow>0200
Jog Setpoint 1	1	0	0	1	0	1	ow>0205
Jog Setpoint 2	1	0	1	1	0	1	ow>020D
Remote Trip	0	0	X	X	X	X	ow>0000
Reset Alarm a)	1	1	0	0	0	0	ow>0300
Reset Alarm b)	1	0	X	0	0	0	Healthy Output Bit 11 goes high ow>0200

## 4-28 Calibration and Start-Up

### Sequence Status

**SEQ STATUS : Tag 537, Mnemonic "ox" (Read Only)**

Reserved bits are undefined when read.

Bit Number	Mask	Name	Comment
0 (lsb)	0x0001	Coast Stop	Coast Stop demanded
1	0x0002	Program Stop	Program (Fast) Stop demanded
2	0x0004	Disable	/Enable demanded
3	0x0008	Run	Drive Start demanded
4	0x0010	Jog	Drive Jog demanded
5	0x0020	Reserved	Undefined
6	0x0040	Alarm	Unacknowledged alarm (Health Store != 0)
7	0x0080	Reserved	Undefined
8	0x0100	Running	Contactor in and drive ready to be enabled
9	0x0200	Enabled	Drive is enabled
10	0x0400	Zero Speed	Zero speed Output TAG 17
11	0x0800	Healthy Output	Healthy Output TAG 12
12	0x1000	Ready	Ready Output TAG 559
13	0x2000	Reserved	Undefined
14	0x4000	Reserved	Undefined
15 (msb)	0x8000	Reserved	Undefined

### Useful Bit Patterns using SEQ STATUS

**Tag 537, Mnemonic "ox" (Read Only) - for example:**

Sequence Status	Comment
0x1B0B	Running
0x044B	Tripped, Run High
0x0447	Tripped, Run Low, Enable Low
0x0C47	Trip Acknowledged, Healthy output TRUE Alarm stays high until drive is restarted.

## Chapter 5 **Control Loops**

This chapter explains the principle of operation, and provides help on setting up the control loops correctly.

### Control Loops - Principle of Operation

- Current Loop
- Speed Loop
- Field Control

### Set-Up Notes

#### Field Weakening

- Standby Field



# Control Loops - Principle of Operation

**NOTE** Selection between Current Control or Speed Control (default) is made by the I DMD ISOLATE (current demand isolate) parameter using Digital I/P3 (Terminal C8). If ENABLED the Drive operates as a current controller, and if DISABLED (the default) it operates as a speed controller.

## MMI Menu Map

1	SETUP PARAMETERS
2	CURRENT LOOP
	I DMD ISOLATE

## Current Loop

The current loop accepts a demand from either the speed loop, or directly from the plant, and forms an error signal which is the difference between demand and average value of feedback. The error signal is fed into a Proportional + Integral compensator which produces the output of the current loop, i.e. the firing angle signal.

In the Drive, the error signal is created in two different forms:

1. The *average* error is computed as the difference between demand and average value of feedback and fed into the Integral part of the P + I algorithm.
2. The *instantaneous* error is computed as the difference between demand and instantaneous value of feedback and is fed into the Proportional part of the P + I algorithm. This gives higher transient performance since it does not contain any time lag, unlike the average which has a built-in lag of 1/6 of mains cycle. However, the average is the true measurement of torque which is the objective of the current control and this is not affected by the small time lag in achieving zero steady-state error.

The firing angle signal is translated into a certain time delay from the mains zero cross point (obtained via a Phase-Lock-Loop) and this results in a firing command being issued to the thyristor stack every 1/6 of a mains cycle in steady-state.

Some special features of the current controller are discussed separately below.

### Adaptive Current Control

The gain of a thyristor 6-pulse converter (voltage-time area over firing angle) drops dramatically at discontinuous values of armature current. Therefore a gain boost is required in the current controller to compensate for that.

In the Drive, this is handled by an adaptive algorithm which allows the current to follow the demand in one step (firing) within the discontinuous region of operation.

### Back EMF (BEMF) Estimate

With the motor at standstill, the firing angle for zero current is 120 degrees. When the motor is rotating at different speeds the firing angle for zero current follows a cosine locus.

It is of paramount importance to track this locus as close as possible throughout the speed range if the current loop bandwidth is to be maintained at its highest possible level during current reversals from master to slave bridge and visa-versa.

There are two reasons for the loss of bandwidth at current reversals:



## 5-2 Control Loops

1. The loss of converter gain needs to be compensated in an accurate way which is the objective of the adaptive algorithm.
2. The above algorithm also relies on the right start-up value of firing angle in the incoming bridge in order to minimise both the "dead-time" (time interval of zero current referred to below) as well as the rise time to the required current demand.

In order to get the right start-up value of firing angle the knowledge of the operating BEMF is necessary. In the Drive, this is achieved by a combination of a hardware peak current detector and appropriate software algorithm.

### Bridge Changeover Delay

The bridge changeover "dead-time", i.e. time interval of zero current, is programmable from 1 to 1500 (via Reserved Menu) with a default value of 1.

*For values from 1 to 6:*

The delay can be set at multiples of 1/6 mains period, i.e. max.  $6 \times 3.33 = 20\text{ms}$  at 50Hz. This is relevant for use with large power converters where it is advisable to allow more time for snubber currents to subside before reversal is enabled. It is also relevant for motors with very large armature inductance where zero current detection is more sensitive and therefore a "factor of safety" in the bridge changeover delay is advisable.

*For values from 7 to 1500:*

The delay corresponds to  $7 \times 1.33\mu\text{s}$  up to  $1500 \times 1.33\mu\text{s} = 2\text{ms}$  maximum.

## Manual Tuning

**NOTE** This procedure is rarely used or required, if possible use Autotune.

If the motor is permanent magnet or (very rarely) wound-field of relatively high permanent magnetism, and the drive is a 4Q drive, then clamp the shaft prior to using the 4Q Autotune process (default). This mode of Autotune produces current pulses on alternate thyristor bridges, and thus the net rotational torque is very low.

There are two circumstances where a manual tuning process would be required:

1. The motor is permanent magnet or (very rarely) wound-field of relatively high permanent magnetism, and the drive is a 2Q drive.
2. The Autotune process has failed with AUTOTUNE ERROR message. The possible causes of an Autotune error are:
  - The motor shaft was rotating, or was caused to rotate.
  - The field current was seen to exceed 6%, when a field-off Autotune had been selected, or the field current stopped during a field-on Autotune.
  - The drive to armature wiring was open-circuit.
  - The discontinuous current boundary was found to exceed 200% of either the stack rating or the nominated motor armature current rating (see **A** below).
  - Large imbalance in the three-phase voltages of the supply (see **B** below).
  - A hardware fault relating to current feedback was detected on the control board.

If the cause of the Autotune failure can be determined and rectified then do so and simply repeat the Autotune process.

## MMI Menu Map

- 1 SETUP PARAMETERS
- 2 CURRENT LOOP
  - MAIN CURR.LIMIT
  - PROP. GAIN
  - INT. GAIN
  - DISCONTINUOUS
  - I DMD. ISOLATE

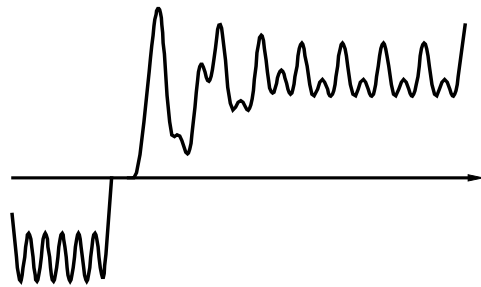
## MMI Menu Map

- 1 SETUP PARAMETERS
- 2 FIELD CONTROL
  - FIELD ENABLE

## MMI Menu Map

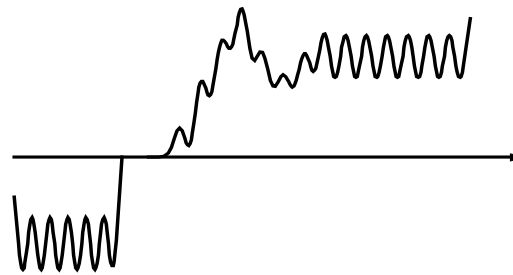
- 1 DIAGNOSTICS
  - CURRENT FEEDBACK

- A.** If a very high motor discontinuous current boundary was the cause of failure, then the discontinuous-region manual tuning process needs to be applied as follows:
1. Set the DISCONTINUOUS parameter to 0, which selects adaptive current control off. When operating in this mode, disable the Missing Pulse alarm, since it is normally masked in the discontinuous region, and it will otherwise give spurious trips at low currents.
  2. Set PROP. GAIN to a low level (typically 1), since it is ineffectual in the discontinuous current operating region.
  3. Set the INT. GAIN to a moderate level (typically 10), sufficient to give fast response throughout the discontinuous current region.
- B.** If imbalance in the three-phase voltages of the supply is the cause of failure then the PI-control manual tuning process needs to be applied as follows:
1. Set FIELD ENABLE to Disabled and clamp the motor shaft, to prevent rotation.
  2. Attach an oscilloscope to the control board armature current monitor test-point (test point IA [see page 5-5], scaled for 1.1V = 100% rated armature current, +ve = reverse bridge, -ve = forward bridge). The scaled armature current value can also be seen in the CURRENT FEEDBACK diagnostic.
  3. Run the drive with a positive speed demand, gradually increasing MAIN CURR. LIMIT until the armature current pulses are seen to just join up. At this point, enter the value of CURRENT FEEDBACK into the DISCONTINUOUS parameter.
  4. Enable the I DMD. ISOLATE parameter (or supply 24V to terminal C8). Use a toggling square-wave (< 20Hz) on the direct demand input (terminal A3) to generate current steps above the discontinuous region. Alternately increase PROP. GAIN and INT. GAIN, as far as possible, until the current loop response is correct (see Tuning Hints below).



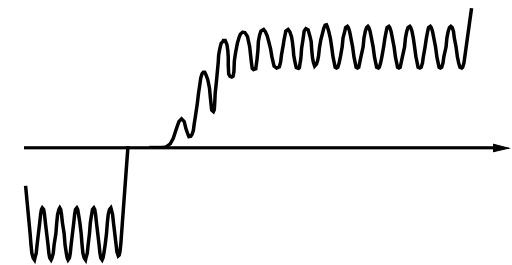
**x**

Current Loop controls incorrectly set. Rapid alternating oscillation = P gain too high



**x**

Current Loop controls incorrectly set. Slower oscillatory response = I gain too high



**✓**

Current Loop controls correctly set.

## 5-4 Control Loops

### Tuning Hints

If the P gain (PROP.GAIN) is too high then the response will exhibit a rapid oscillation, that alternates on consecutive current pulses.

If the I gain (INT. GAIN) is too high then the result will be a slower oscillatory response (under-damped), with a period of multiple pulses.

If the I gain (INT. GAIN) is too low then the response will exhibit a long settling tail.

### Diagnostics

The diagnostic point for "real" armature current is the first (left-hand side) test point below the calibration panel. This will give 1.1V average for 100% current. It will also give the operating bridge, i.e. it will be negative for the Master bridge (positive current demand) and positive for the Slave bridge (negative current demand).

### Current Demand Rate Limit (di/dt)

Access to the di/dt limit is currently reserved for Parker SSD Drives personnel only in the Reserved Menu.

This is a limit imposed on the rate of change of the current demand. It is to be used for motors with commutation limitations, mechanical systems that cannot absorb rapid torque transients and also as a means of limiting current overshoot for large current swings (e.g. 0 → 200%). The default value is set at 35% (i.e. maximum allowable change is 35% of FLC in 1/6 mains cycle) which has no practical effect on the current response between 0 and 100%.

---

## Speed Loop

The speed loop accepts a demand from either an outside loop (i.e. position loop) or directly from the plant and forms the error signal which is the difference between demand and feedback. The error signal is fed into a Proportional + Integral compensator which produces the output of the speed loop, i.e. the current demand signal.

The integral gain is translated into a Time Constant (secs) in the MMI which defines more clearly the function of the compensator against a certain load time constant.

### Speed Loop Synchronised with Current Loop

The proportional part of the P+I algorithm is executed immediately before each run of the current loop, thus ensuring minimum time lag and therefore maximum bandwidth.

### Combined Analog Tacho/Encoder Feedback

By using the analog tacho feedback on the Proportional part of the P + I algorithm and the encoder feedback on the Integral part (using similar principle as in the current loop), the Drive combines maximum transient response with the increased steady-state accuracy of the digital feedback. Please refer to Parker SSD Drives Engineering Department for assistance in the use of this feature.

## Field Control

### Set-Up Notes

Use the field AUTOTUNE facility to tune the field current control loop.

#### Initial Conditions

1. Main contactor open, i.e. no Start/Run signal at terminal C3.
2. Set the AUTOTUNE parameter to OFF.
3. Program Stop (terminal B8) and Coast Stop (terminal B9) should be high, i.e. 24V.
4. The motor should be stationary.

#### MMI Menu Map

1 CONFIGURE DRIVE

AUTOTUNE

### Caution

Never perform a field autotune if the motor is turning above base speed, since this will generate armature voltages that can overvoltage the armature circuit.

#### Performing an Autotune

1. Set the AUTOTUNE parameter to FIELD.
2. Close the main contactor, i.e. Start/run signal to terminal C3.
3. Energise the Enable terminal (C5).

*The Autotune sequence is initiated. When complete (after approximately 5 seconds), the main contactor is opened signalling the end of the sequence and the AUTOTUNE parameter is reset to OFF.*

4. Perform a PARAMETER SAVE now. Refer to Chapter 6: "The Keypad - Saving Your Application".

#### MMI Menu Map

1 SETUP PARAMETERS

2 FIELD CONTROL

3 FLD.CURRENT VARS

SETPOINT

PROP. GAIN

INT. GAIN

>> FLD.WEAK VARS

#### Autotune Failed?

The AUTOTUNE ERROR message may result if:

- The field terminals are open-circuit or short-circuit.
- More than 180% or less than 20% field voltage is required to drive the current configured in the FIELD CURRENT parameter.
- The natural field time-constant is greater than 5 seconds.

In these cases, a manual tuning process will be required, much like the manual tuning of the armature current loop. With manual tuning, one convenient method of producing field current demand steps is to set the field demand (SETPOINT) to 50% and then use the drive enable to move to and from the 'quench' and 'standby' modes to create transients. Monitor the field current at control board test-point IF, scaled 4V = 100% rated field current.

## 5-6 Control Loops

### Current Control

The field current loop can accept a demand directly from the plant and/or an outside field weakening loop and forms the error signal which is the difference between demand and feedback. The error signal is fed into a P + I compensator which produces the output of the field loop, i.e. the field firing angle signal.

The firing angle signal is translated into a certain time delay from the mains zero cross point (obtained via the same Phase-Lock-Loop as for the armature) and this results into a firing command being issued to the field bridge every 1/2 of a mains cycle in steady-state.

### Voltage Control

This offers the facility of an open-loop voltage control for motors which do not provide in the nameplate the field current rating. The field voltage is controlled by the specified FLD. VOLTS RATIO which defaults to 90.0%. This is the maximum dc Volts that can be obtained for a given ac RMS input in a single-phase rectifier, i.e. 370V dc for 415V ac supply. The specified ratio determines directly the firing angle at which the controller operates and therefore the thermal effects on the field resistance as well as mains voltage variations are not compensated for. It is also worth noting that in this mode the field overcurrent alarm is not active (since there is no current scaling) and therefore this mode is not recommended for use with supplies much greater than the field voltage rating.

### Field Weakening

Motor field weakening is used to extend the speed region of the motor above its base speed (the motor speed resulting at rated armature voltage, rated armature current and rated field current), in a constant power mode of operation (motor torque reducing with increasing speed).

*Note that the motor should be rated for field-weakened operation, in terms of rotational speed and reduced field current, before utilising this mode.*

The drive includes a field weakening loop that, above base speed, can control the field current demand to the correct level required to maintain motor back-EMF at a pre-defined level.

**NOTE** Field weakening is not possible when running with Armature Volts feedback. Although field weakening can be “Enabled” in this instance, a software interlock clamps the field demand at 100% and will not allow the field weakening to reduce it.

When the back-EMF measurement is higher than the MAX VOLTS setting (default 100%) the excess voltage is presented to the field weakening gain-limited PI controller as an error, and this controller reduces the field current demand accordingly.

The gain-limited controller is tuned as follows:

1. Ensure that the armature current, speed and field current loops are correctly tuned.
2. Enable field weakening control (FLD. WEAK ENABLE = ENABLE), with analogue tachogenerator, encoder or microtach speed feedback, correctly installed and configured for extended speed operation.
3. Run the drive and slowly increase the speed demand so that the field is being weakened by the gain-limited PI controller. Change the MAX VOLTS parameter down and up by 10% to generate field current transients.
4. Alternately increase the P gain (using the dc-gain parameter EMF GAIN) and reduce the integral time-constant (parameter EMF LEAD) until the loop is correctly tuned (see the Current Loop "Tuning Hints" above).

#### MMI Menu Map

- 1 SETUP PARAMETERS
- 2 FIELD CONTROL
- 3 FLD.CURRENT VARS
- 4 FLD.WEAK VARS
  - FLD. WEAK ENABLE
  - EMF LEAD
  - EMF LAG
  - EMF GAIN
  - MIN FLD.CURRENT
  - MAX VOLTS
  - BEMF FBK LEAD
  - BEMF FBK LAG

It is the over-voltage of the back-EMF that provides the error which drives this controller to weaken the field, and the over-voltage occurring during ramp through base speed is dependent on the rate of ramp. If the over-voltage is excessive, then it can be reduced most simply by switching to the ADVANCED field weakening mode. In the STANDARD mode, provide advanced notice of the overvoltage, in order to reduce it, by employing the lag/lead filter applied to the back-emf measurement. This filter is disabled by default through its equal lag and lead time-constant settings, increase the lead time-constant to provide advance notice of weakening to the controller.

#### Notes on field weakening controller usage:

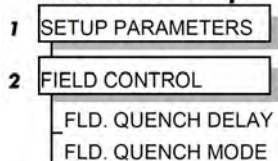
1. **The use of the back-EMF filter should be limited to 3:1 ratio of lag to lead time-constants, and the field current loop and field weakening controller may need to be de-tuned, in order to maintain overall loop stability.**
2. **The gain-limit of the PI controller may also be adjusted in order to optimise the balance between transient and static back-EMF over-voltage. Lower lag time-constants and lower dc-gains result in more static back-EMF over-voltage, but allow for more back-EMF filter advance during speed ramps. The ratio of lag to lead time-constants should be typically maintained above 10 to avoid significant dc over-voltage on the back-EMF.**

## ADVANCED Mode

The ADVANCED mode of the field weakener offers the following advantages over the STANDARD mode.

1. **A feedforward control is applied in addition to the gain-capped PI controller.** This term, which compares the actual speed feedback to the calculated base speed, estimates the required field weakening. The use of this control term significantly reduces the overvoltage on transition through base speed, prior to the application of any lead-lag compensation. Transitions through base speed can be more rapid without overvoltage as a result. In addition, false weakening of the field is eliminated for speed transients just below base speed, if the lead-lag back-emf filter is left disabled.
2. **The back-emf control loop is gain compensated for reducing field level.** Motor back-emf is related directly to the motor speed, and to the motor flux level. As a result the transfer gain from field current to back-emf is directly related to motor speed. An adaptive gain element is included in the ADVANCED mode that increases back-emf loop gain below full speed, and this allows improved control performance at the field weakening boundary whilst maintaining stability at full speed.
3. **The speed control loop is gain compensated for reducing field level.** Motor torque is related directly to both armature current and motor flux level. An adaptive gain element is included in the ADVANCED mode that increases speed loop gain below full field, and this maintains speed control performance into the field weakened operating region. Note that the lag-lead back-emf filter can still be applied in the ADVANCED mode to further improve voltage control during rapid excursions into field weakening.

#### MMI Menu Map



## Standby Field

When the armature current gets quenched, a timer starts timing-out and after a certain delay (FLD. QUENCH DELAY) it will either quench the field totally (FLD. QUENCH MODE = QUENCH) or will reduce it to 50% of the current or voltage setpoint (FIELD QUECH MODE = STANDBY). This applies to both current and voltage modes.

## 5-8 Control Loops

# Chapter 6 **The Keypad**

This chapter details the menus, control keys and keypad indications.

## Connecting the 6911 Keypad

- Control Key Definitions

Keys for Programming the Drive

Keys for Operating the Drive Locally

- Indications

Keypad Alarm Messages

Keypad LEDs

## The Menu System

- The Local Menu

The L/R Key

The PROG Key

- Navigating the Menu System
- Changing a Parameter Value
- The Menu System Map

## The Keypad Menus

DIAGNOSTICS

SETUP PARAMETERS

PASSWORD

ALARM STATUS

MENUS

SERIAL LINKS

SYSTEM

PARAMETER SAVE

FUNCTION BLOCKS

## Menu Shortcuts and Special Key Combinations

Quick Tag Information

Changing the Stack Size (3-button reset)

Resetting to Factory Defaults (2-button reset)

- Cloning Feature

## How to Save, Restore and Copy your Settings

- Saving Your Application
- Restoring Saved Settings
- Copying an Application





# Connecting the 6911 Keypad

The Keypad is a plug-in MMI (Man-Machine Interface) option that allows full use of the drive's features.

It provides local control of the drive, monitoring, and complete access for application programming.

Insert the Keypad into the front of the drive (replacing the blank cover and plugging into the RS232 programming port); or mount it up to 3 metres away using the optional panel mounting kit with connecting lead.

Refer to Chapter 3: "Installing the Drive" - Remote Mounting the Keypad.

On power-up, a calibration message is displayed. This is quickly replaced by a default Welcome screen showing the product description and Product Code.

The Welcome screen is at the top of the menu system.

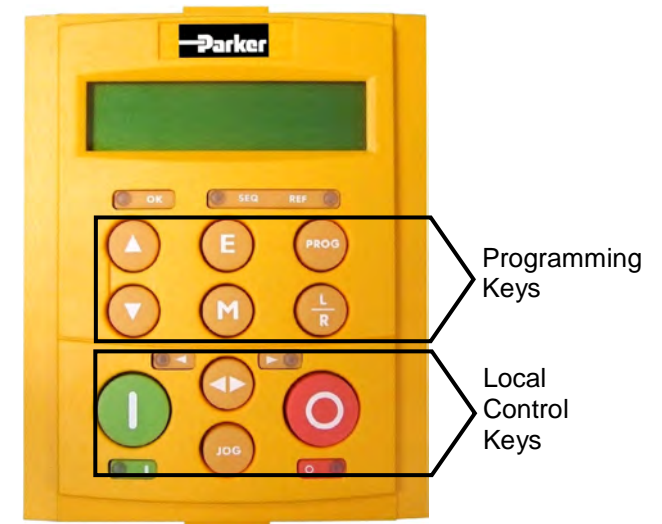
The drive can operate in one of two modes:

**Remote Control Mode:** Allowing complete access for application programming

**Local Control Mode:** Providing local control and monitoring of the drive

Local control keys are inactive when Remote control mode is selected and vice versa, with one exception; the **L/R** key toggles Local or Remote control modes and so is always operative.

The drive always initialises in Remote control mode, and with the Local control keys inactive, it is unlikely that the motor could be started accidentally.











**Figure 6-1 6911 Keypad**





## Control Key Definitions

### Keys for Programming the Drive

**NOTE** Refer to “Navigating the Menu System”, page 6-7 for a quick-start to using the menu.

<p>UP</p> 	<p><i>Navigation</i> - Moves upwards through the list of parameters.</p> <p><i>Parameter</i> - Increments the value of the displayed parameter.</p> <p><i>Command Acknowledge</i> - Confirms action when in a command menu.</p>
<p>DOWN</p> 	<p><i>Navigation</i> - Moves downwards through the list of parameters.</p> <p><i>Parameter</i> - Decrements the value of the displayed parameter.</p>
<p>ESCAPE</p> 	<p><i>Navigation</i> - Displays the previous level's Menu.</p> <p><i>Parameter</i> - Returns to the parameter list.</p> <p><i>Trip Acknowledge</i> - Acknowledges displayed Trip or Error message.</p>
<p>MENU</p> 	<p><i>Navigation</i> - Displays the next Menu level, or the first parameter of the current Menu.</p> <p><i>Parameter</i> - Holding <b>M</b> down when a parameter is displayed shows that parameter's Tag No. Repeated pressing at a writable parameter moves a cursor across the value to allow rapid increment/decrement of the parameter value.</p>
<p>PROG</p> 	<p><i>Navigation</i> - When in Local mode, displays the previous MMI menu whilst remaining in Local mode enabling changes to be made to parameters not available in Local menu. The key has no function in Remote mode.</p>
<p>LOCAL/ REMOTE</p> 	<p><i>Control</i> - Toggles between Remote and Local Control Modes for both Start/Stop (Seq) and Speed Control (Ref). When toggling, the display automatically goes to the relevant SETPOINT screen, and the SETPOINT (LOCAL) screen will have the  and  keys enabled to alter the setpoint.</p>

## Keys for Operating the Drive Locally

<p><b>FORWARD/ REVERSE</b></p> 	<p><i>Control</i> - Changes the direction of motor rotation when in Local mode, indicated by the display. Selects between two jog speeds when in Jog mode. This key has no function in Remote mode.</p>
<p><b>JOG</b></p> 	<p><i>Control</i> - Runs the motor at a speed determined by the JOG SPEED 1 parameter. When the key is released, the Drive returns to "stopped". Only operates when the Drive is "stopped" and in Local mode. This key has no function in Remote mode.</p>
<p><b>RUN</b></p> 	<p><i>Control</i> - Runs the motor at a speed determined by the LOCAL SETPOINT.</p> <p><i>Trip Reset</i> - Resets any trips and then runs the motor as above. Only operates when the Drive is in Local mode.</p>
<p><b>STOP/RESET</b></p> 	<p><i>Control</i> - Stops the motor. Only operates when the Drive is in Local mode.</p> <p><i>Trip Reset</i> - Resets any trips and clears displayed message if trip is no longer active.</p>

## Indications

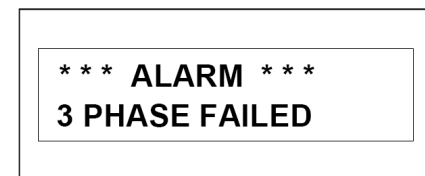
### Keypad Alarm Messages

An alarm message will be displayed on the MMI when the unit is tripped.

- The Drive has tripped.  
*The top line indicates a trip has occurred while the bottom line gives the reason for the trip. See example opposite.*

Acknowledge the trip message by pressing the **E** key. Press the **STOP/RESET** key to restore the Health LED.

Refer to Chapter 7: "Trips and Fault Finding" for trip messages and reasons.

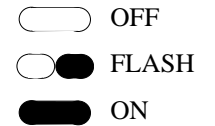


## 6-4 The Keypad

### Keypad LEDs

There are seven LEDs that indicate the status of the Drive. Each LED is considered to operate in three different ways:

The LEDs are labelled HEALTH, RUN, STOP, FWD, REV, and LOCAL (as SEQ and REF). Combinations of these LEDs have the following meanings:



HEALTH (OK)	RUN	STOP	Drive State
<input type="radio"/> <input checked="" type="radio"/>	<input type="radio"/> <input checked="" type="radio"/>	<input type="radio"/> <input checked="" type="radio"/>	Re-Configuration
<input type="radio"/> <input checked="" type="radio"/>	<input type="radio"/>	<input checked="" type="radio"/>	Tripped
<input checked="" type="radio"/>	<input type="radio"/>	<input checked="" type="radio"/>	Stopped
<input checked="" type="radio"/>	<input type="radio"/>	<input type="radio"/> <input checked="" type="radio"/>	Stopping
<input checked="" type="radio"/>	<input type="radio"/> <input checked="" type="radio"/>	<input type="radio"/>	Running with zero reference
<input checked="" type="radio"/>	<input checked="" type="radio"/>	<input type="radio"/>	Running
<input checked="" type="radio"/>	<input type="radio"/> <input checked="" type="radio"/>	<input type="radio"/> <input checked="" type="radio"/>	Autotuning

FWD	REV	Forward / Reverse State
<input checked="" type="radio"/>	<input type="radio"/>	Requested direction and actual direction are forward
<input type="radio"/>	<input checked="" type="radio"/>	Requested direction and actual direction are reverse
<input type="radio"/> <input checked="" type="radio"/>	<input type="radio"/>	Requested direction is forward but actual direction is reverse
<input type="radio"/>	<input type="radio"/> <input checked="" type="radio"/>	Requested direction is reverse but actual direction is forward

LOCAL SEQ	LOCAL REF	Local / Remote Mode
<input type="radio"/>	<input type="radio"/>	Start/Stop (Seq) and Speed Control (Ref) are controlled from the terminals
<input checked="" type="radio"/>	<input checked="" type="radio"/>	Start/Stop (Seq) and Speed Control (Ref) are controlled using the Keypad keys

# The Menu System

The menu system is divided into a 'tree' structure with 9 "MENU LEVEL" main menus.

Consider these main menus to be at Menu Level 1 (refer to the The Menu System Map, page 6-8). Parameters contained in Menu Level 1 are the most frequently used, as you descend the menu levels the parameters are less frequently used.

The Keypad has selectable "viewing levels" which can restrict the view of the Remote menu system, refer to "Selecting a Menu Viewing Level", page 6-17.

Below is a simple description of the main menus:

- **DIAGNOSTICS:** a view of important diagnostic parameters.
- **SETUP PARAMETERS:** contains all the function block parameters for setting-up the Drive.
- **PASSWORD:** contains all the Password parameters required for security.
- **ALARM STATUS:** a view of the alarm diagnostic parameters contained in the FUNCTION BLOCKS menu.
- **MENUS:** allows full or reduced menu displays on the Keypad, and selects the display language.
- **SERIAL LINKS:** contains all the parameters for external communications set-up and operation.
- **SYSTEM:** contains all the parameters for I/O configuration.
- **PARAMETER SAVE:** save the application/parameters.
- **CONFIGURE DRIVE:** a view of the important parameters used when setting-up the drive.
- **FUNCTION BLOCKS:** a view of all available function blocks, as seen in the Configuration Tool.

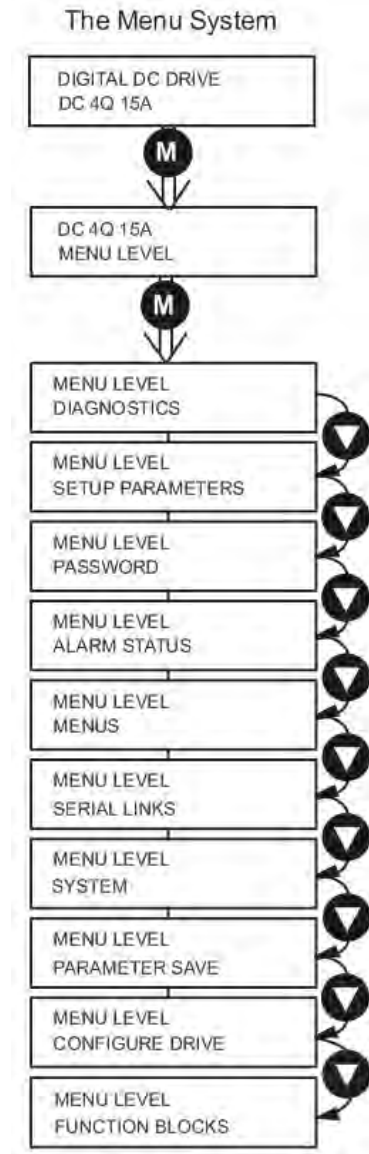


Figure 6-2 The Menu System showing Main Menus and Key Presses

## 6-6 The Keypad

### The Local Menu

There is also a separate Local menu which provides Local Setpoint information. This menu can be accessed from anywhere in the Menu System by pressing the **L/R** key. Holding the **M** key down in the Local menu will display additional Feedback information. A toggle to the Local menu displays whichever is in force, Forward or Reverse, previously selected by the **FWD/REV** key.

### The L/R Key

The **L/R** key (Local/Remote) only operates when the motor is stopped. It toggles the drive between Local or Remote control and an appropriate menu on the Keypad is displayed; either a Local menu when in Local control, or a main programming menu from the Menu System when in Remote control.

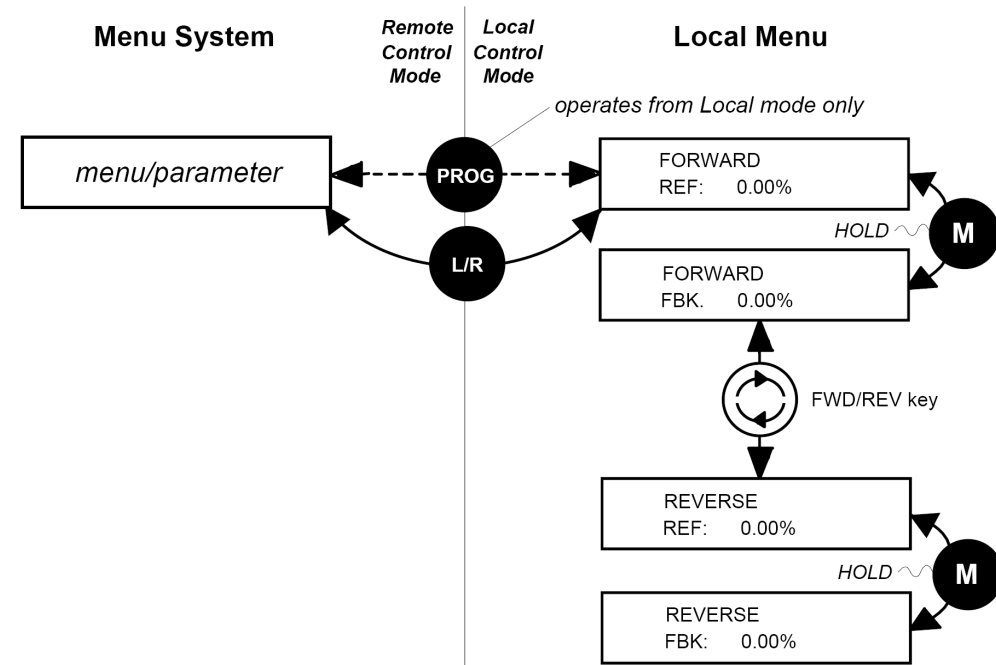
When in Local control, the Local LEDs, SEQ and REF, are illuminated and the RUN, STOP, JOG, FORWARD/REVERSE, UP and DOWN local control keys can be used to control the motor speed and direction.

Pressing the **L/R** key when in Local control mode selects Remote control mode and returns you to your previous menu in the Menu System.

### The PROG Key

The **PROG** key only operates when in Local control mode. It toggles the display between the Local menu and the main Menu System but the drive remains in Local control. Thus, the **PROG** key allows you to make changes to parameters normally available in Remote control mode whilst remaining in Local mode operation.

**HINT:** When operating the drive locally, it is quite useful to have a relevant parameter selected in the main Menu System for easy access.



**Figure 6-3**  
**Viewing the Local Menu**

## Navigating the Menu System

The Menu System can be thought of as a map which is navigated using the four keys shown opposite.

- Keys **E** and **M** navigate through the menu levels.
- The up (▲) and down (▼) keys scroll through the Menu and Parameter lists.

Menus can contain other menus at a lower level in the tree structure, parameters, or a mixture of both.

The keys are used as above to select a parameter (a parameter has a selection (i.e. ON/OFF) or a value displayed on the bottom line).

**HINT:** Remember that because the Menu and Parameter lists are looped, the ♦ key can quickly move you to the last Menu or Parameter in the loop. The keys will repeat if you hold them down. This is an easy way to step through and view a menu's contents.

## Changing a Parameter Value

With the Parameter you want on view, three of the keys now perform different functions:

- Change a selection (i.e. ON/OFF) using the up (▲) and down (▼) keys.
- Change a value as follows:

*The up (▲) and down (▼) keys increment/decrement the value at a rate determined by the right hand character of the value, indicated by the appearance of a cursor.*

- ◆ If the cursor is positioned as 100.0, then the value will change by tenths of a unit
- ◆ If the cursor is positioned as 100.0, then the value will change in whole units, etc.

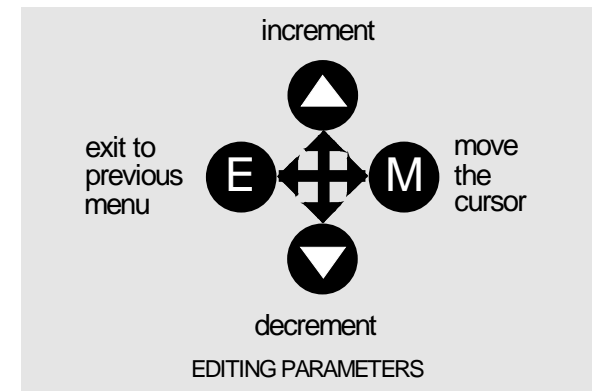
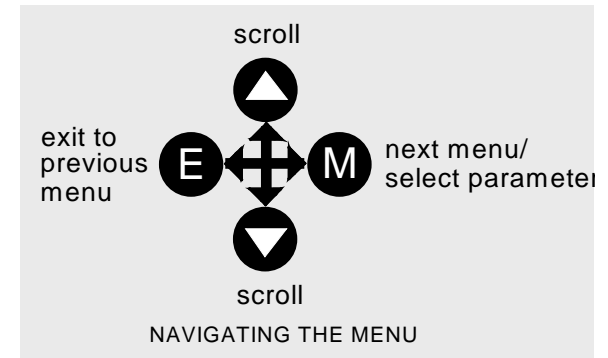
*The up (▲) and down (▼) keys will repeat if you hold them down and, at a preset point, the cursor will progressively move one character to the left and increment/decrement the value at an increased rate.*

*Alternatively, you can move the cursor manually by pressing the **M** key. Repeated pressing moves the cursor right to left along the value.*

*The cursor times-out after approximately half a second, so use the **M** key and up (▲) and down (▼) keys promptly once the cursor is in position.*

### NOTE

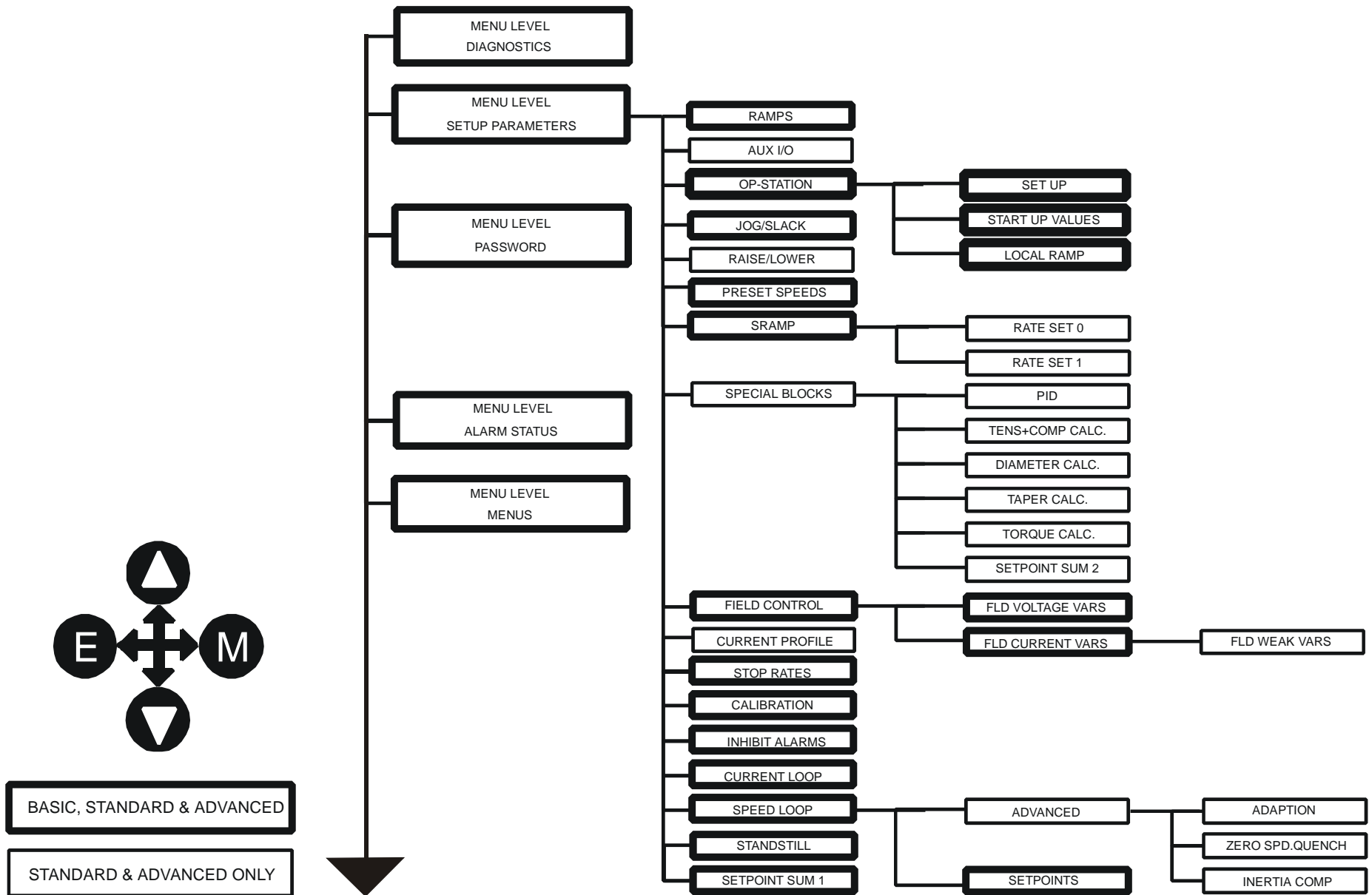
**A cursor appears under all numerical values except for parameters in the Diagnostics and Alarm Status menus whose values provide information only.**

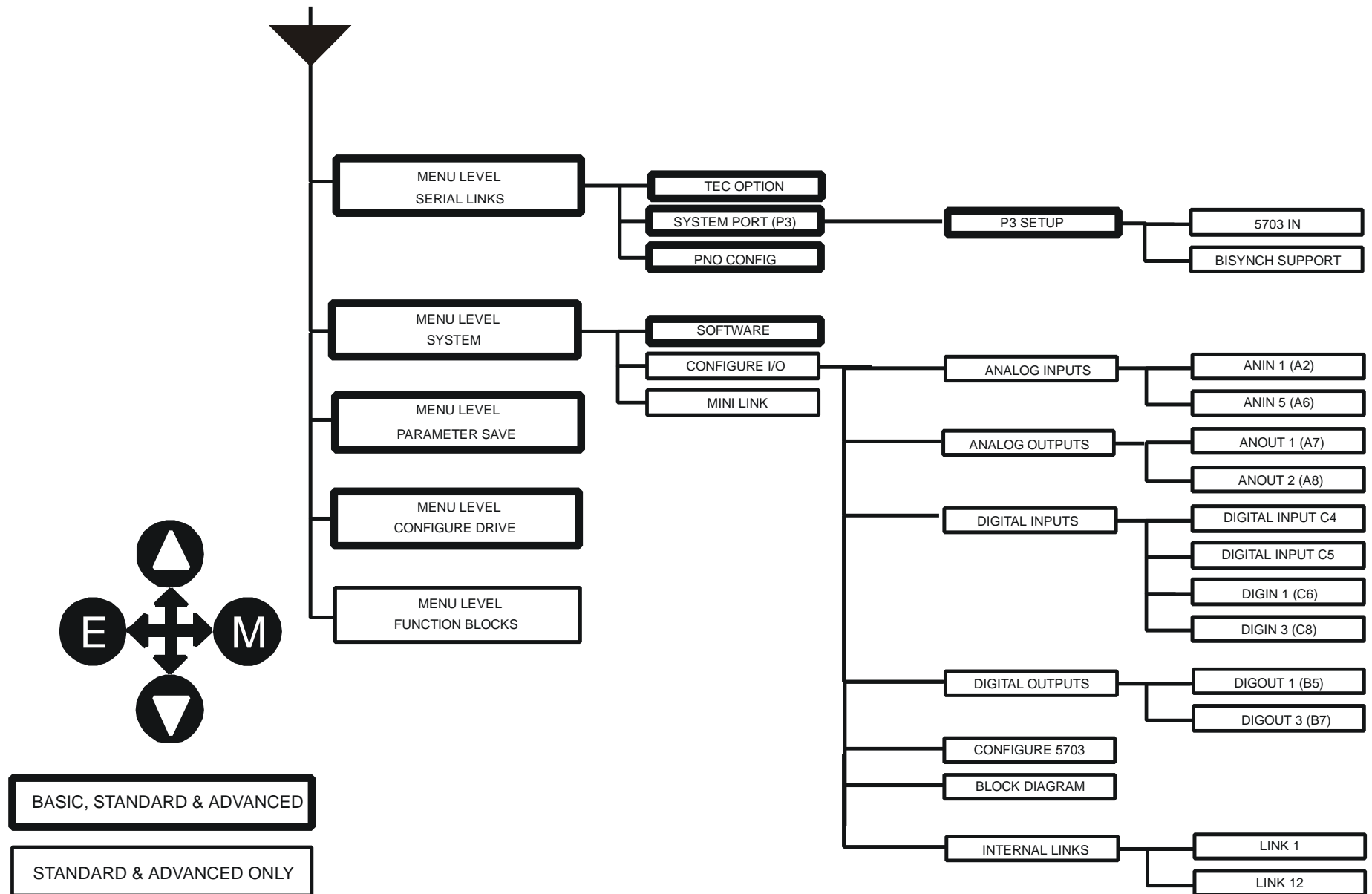


A Parameter showing a cursor under the value



# The Menu System Map





# The Keypad Menus

## MMI Menu Map

1

DIAGNOSTICS
SPEED DEMAND
SPEED FEEDBACK
SPEED ERROR FILT
SPEED LOOP O/P
CURRENT DEMAND
CURRENT FEEDBACK
CURRENT FBK.AMPS
IaFbk UNFILTERED
IaDmd UNFILTERED
POS. I CLAMP
NEG. I CLAMP
ACTUAL POS I LIM
ACTUAL NEG I LIM
INVERSE TIME O/P
AT CURRENT LIMIT
AT ZERO SPEED
AT ZERO SETPOINT
AT STANDSTILL
RAMPING
PROGRAM STOP
COAST STOP
DRIVE START
DRIVE ENABLE
OPERATING MODE
FIELD ENABLED
FIELD DEMAND
FIELD I FBK.
FIELD I FBK.AMPS
UNFIL.FIELD FBK
FLD.FIRING ANGLE
ANIN 1 (A2)
ANIN 2 (A3)
ANIN 3 (A4)
ANIN 4 (A5)
ANIN 5 (A6)

## DIAGNOSTICS

The DIAGNOSTICS Menu table describes all the parameters in the MMI's DIAGNOSTICS menu. These parameters are "read-only" and are very useful for tracing configuration problems. The list is shown in MMI order, and the parameter names are as displayed by the 6901 Keypad and the DSE Configuration Tool.

### DIAGNOSTICS (MMI only)

Parameter	Tag	Range	SETUP PARAMETERS Function Blocks
<b>SPEED DEMAND</b>	<b>89</b>	—.xx %	
Speed loop total setpoint after the ramp-to-zero block.			<i>Refer to SPEED LOOP</i>
<b>SPEED FEEDBACK</b>	<b>207</b>	—.xx %	
Speed loop feedback.			<i>Refer to FEEDBACKS</i>
<b>SPEED ERROR FILT</b>	<b>297</b>	—.xx %	
Speed loop error.			<i>Refer to SPEED LOOP</i>
<b>SPEED LOOP O/P</b>	<b>356</b>	—.xx %	
Output from speed loop PI.			<i>Refer to SPEED LOOP</i>
<b>CURRENT DEMAND</b>	<b>299</b>	—.xx %	
Current loop demand (speed error PI output or external current demand clamped by all the current limits).			<i>Refer to CURRENT LOOP</i>
<b>CURRENT FEEDBACK</b>	<b>298</b>	—.xx %	
Scaled and filtered current feedback.			<i>Refer to FEEDBACKS</i>
<b>CURRENT FBK. AMPS</b>	<b>538</b>	—.xx AMPS	
Scaled and filtered armature current in Amps.			<i>Refer to CURRENT LOOP</i>
<b>IaFbk UNFILTERED</b>	<b>65</b>	—.xx %	
Scaled current feedback (unfiltered).			<i>Refer to CURRENT LOOP</i>
<b>IaDmd UNFILTERED</b>	<b>66</b>	—.xx %	
Scaled current demand (unfiltered).			<i>Refer to CURRENT LOOP</i>
<b>POS. I CLAMP</b>	<b>87</b>	—.x % (h)	
Positive current clamp.			<i>Refer to CURRENT LOOP</i>
<b>NEG. I CLAMP</b>	<b>88</b>	—.x % (h)	
Negative current clamp.			<i>Refer to CURRENT LOOP</i>

## MMI Menu Map cont.

1	DIAGNOSTICS
	ANOUT 1 (A7)
	ANOUT 2 (A8)
	START (C3)
	DIGITAL INPUT C4
	DIGITAL INPUT C5
	DIGIN 1 (C6)
	DIGIN 2 (C7)
	DIGIN 3 (C8)
	DIGOUT 1 (B5)
	DIGOUT 2 (B6)
	DIGOUT 3 (B7)
	RAISE/LOWER O/P
	PID OUTPUT
	PID CLAMPED
	PID ERROR
	SPT SUM OUTPUT
	RAMP OUTPUT
	PRESET O/P
	SRAMP OUTPUT
	OUTPUT FPM
	SPEED SETPOINT
	TERMINAL VOLTS
	BACK EMF
	ARM VOLTS FBK
	TACH INPUT
	UNFIL.TACH INPUT
	ENCODER
	UNFIL.ENCODER
	UNFIL.SPD.FBK
	UNFIL.SPD.ERROR
	CONTACTOR CLOSED
	HEALTH LED
	READY
	DRIVE RUNNING
	SYSTEM RESET

## DIAGNOSTICS (MMI only)

Parameter	Tag	Range	SETUP PARAMETERS Function Blocks
<b>ACTUAL POS I LIM</b> Overall positive current limit value.	<b>67</b>	—x % (h)	<i>Refer to CURRENT LOOP</i>
<b>ACTUAL NEG I LIM</b> Overall negative current limit value.	<b>61</b>	—x % (h)	<i>Refer to CURRENT LOOP</i>
<b>INVERSE TIME O/P</b> Inverse time clamp output level.	<b>203</b>	—xx %	<i>Refer to INVERSE TIME</i>
<b>AT CURRENT LIMIT</b> Current demand is being restrained by the overall current clamp.	<b>42</b>	FALSE / TRUE	<i>Refer to CURRENT LOOP</i>
<b>AT ZERO SPEED</b> At zero speed feedback.	<b>77</b>	FALSE / TRUE	<i>Refer to STANDSTILL</i>
<b>AT ZERO SETPOINT</b> At zero speed demand.	<b>78</b>	FALSE / TRUE	<i>Refer to STANDSTILL</i>
<b>AT STANDSTILL</b> AT ZERO SPEED and AT ZERO SETPOINT.	<b>79</b>	FALSE / TRUE	<i>Refer to STANDSTILL</i>
<b>RAMPING</b> The SETPOINT ramp function block is limiting the rate of change of Speed Setpoint.	<b>113</b>	FALSE / TRUE	<i>Refer to RAMPS</i>
<b>PROGRAM STOP</b> State of program stop (Terminal B8). When B8 is at 24V, then PROGRAM STOP is FALSE.	<b>80</b>	FALSE / TRUE	<i>Refer to SELECT</i>
<b>COAST STOP</b> State of coast stop (Terminal B9). When B9 is at 24V, then COAST STOP is FALSE.	<b>525</b>	FALSE / TRUE	<i>Refer to SELECT</i>
<b>DRIVE START</b> Controller start/run command.	<b>82</b>	ON / OFF	<i>Refer to SELECT</i>
<b>DRIVE ENABLE</b> Drive speed and current loop are enabled/quenched.	<b>84</b>	ENABLED / DISABLED	<i>Refer to SELECT</i>

## 6-12 The Keypad

<b>DIAGNOSTICS (MMI only)</b>			
<b>Parameter</b>	<b>Tag</b>	<b>Range</b>	<b>SETUP PARAMETERS Function Blocks</b>
<b>OPERATING MODE</b>	<b>212</b>	<b>0 to 7</b>	
Indicates whether the drive is in RUN, JOG 1....STOP etc.			
0 : STOP			
1 : STOP			
2 : JOG SP. 1			
3 : JOG SP. 2			
4 : RUN			
5 : TAKE UP SP. 1			
6 : TAKE UP SP. 2			
7 : CRAWL			
			<i>Refer to JOG/SLACK</i>
<b>FIELD ENABLED</b>	<b>169</b>	<b>ENABLED / DISABLED</b>	
Drive field loop is enabled/quenched.			
			<i>Refer to FIELD CONTROL</i>
<b>FIELD DEMAND</b>	<b>183</b>	<b>—.xx %</b>	
The meaning of field demand depends upon which mode of field control is in force; in current control FIELD DEMAND is the current setpoint to the field loop, in voltage mode FIELD DEMAND is the voltage ratio to the field controller.			
			<i>Refer to FIELD CONTROL</i>
<b>FIELD I FBK.</b>	<b>300</b>	<b>—.xx %</b>	
Scaled and filtered field current feedback.			
			<i>Refer to FIELD CONTROL</i>
<b>FIELD I FBK.AMPS</b>	<b>539</b>	<b>—x AMPS</b>	
Scaled and filtered field current feedback in Amps.			
			<i>Refer to FIELD CONTROL</i>
<b>UNFIL.FIELD FBK</b>	<b>181</b>	<b>—.xx %</b>	
Scaled field current (unfiltered).			
			<i>Refer to FEEDBACKS</i>
<b>FLD.FIRING ANGLE</b>	<b>184</b>	<b>—.xx DEG</b>	
Field firing angle in degrees: 155 degrees is the value for back stop (min field) and 5 degrees is the value for front stop (max field).			
			<i>Refer to FIELD CONTROL</i>
<b>ANIN 1 (A2)</b>	<b>50</b>	<b>—.xx VOLTS</b>	
Speed setpoint no. 1.			
			<i>Refer to ANALOG INPUTS</i>
<b>ANIN 2 (A3)</b>	<b>51</b>	<b>—.xx VOLTS</b>	
Hardwired. Speed setpoint no. 2 or current demand if C8 = ON.			
			<i>Refer to ANALOG INPUTS</i>
<b>ANIN 3 (A4)</b>	<b>52</b>	<b>—.xx VOLTS</b>	
Speed setpoint no. 3 (ramped).			
			<i>Refer to ANALOG INPUTS</i>

<b>DIAGNOSTICS (MMI only)</b>			
<b>Parameter</b>	<b>Tag</b>	<b>Range</b>	<b>SETUP PARAMETERS Function Blocks</b>
<b>ANIN 4 (A5)</b> Speed setpoint no. 4 or negative current clamp if C6 = ON.	<b>53</b>	<b>—.xx VOLTS</b>	<i>Refer to ANALOG INPUTS</i>
<b>ANIN 5 (A6)</b> Main current limit or positive current clamp if C6 = ON.	<b>54</b>	<b>—.xx VOLTS</b>	<i>Refer to ANALOG INPUTS</i>
<b>ANOUT 1 (A7)</b> Scaled speed feedback.	<b>55</b>	<b>—.xx VOLTS</b>	<i>Refer to ANALOG OUTPUTS</i>
<b>ANOUT 2 (A8)</b> Total speed setpoint.	<b>56</b>	<b>—.xx VOLTS</b>	<i>Refer to ANALOG OUTPUTS</i>
<b>START (C3)</b> Start/Run terminal.	<b>68</b>	<b>ON / OFF</b>	<i>Refer to SEQUENCING</i>
<b>DIGITAL INPUT C4</b> Jog/Take-up Slack terminal.	<b>69</b>	<b>ON / OFF</b>	<i>Refer to DIGITAL INPUTS</i>
<b>DIGITAL INPUT C5</b> Electronic enable/disable (quench) terminal (ON = Enabled).	<b>70</b>	<b>ON / OFF</b>	<i>Refer to DIGITAL INPUTS</i>
<b>DIGIN 1 (C6)</b> Symmetrical current clamps/Asymmetrical (bipolar) current clamps (ON = Bipolar).	<b>71</b>	<b>ON / OFF</b>	<i>Refer to DIGITAL INPUTS</i>
<b>DIGIN 2 (C7)</b> Ramp hold input (ON = Hold).	<b>72</b>	<b>ON / OFF</b>	<i>Refer to DIGITAL INPUTS</i>
<b>DIGIN 3 (C8)</b> Current demand isolate; giving speed or current mode of operation. (ON = Current mode).	<b>73</b>	<b>ON / OFF</b>	<i>Refer to DIGITAL INPUTS</i>
<b>DIGOUT 1 (B5)</b> At zero speed.	<b>74</b>	<b>ON / OFF</b>	<i>Refer to DIGITAL OUTPUTS</i>
<b>DIGOUT 2 (B6)</b> Drive healthy. Health is also displayed on the front panel LED, always ON when the start is low.	<b>75</b>	<b>ON / OFF</b>	<i>Refer to DIGITAL OUTPUTS</i>
<b>DIGOUT 3 (B7)</b> Drive ready to run (all alarms healthy and mains synchronisation achieved).	<b>76</b>	<b>ON / OFF</b>	<i>Refer to DIGITAL OUTPUTS</i>

## 6-14 The Keypad

<b>DIAGNOSTICS (MMI only)</b>			
<b>Parameter</b>	<b>Tag</b>	<b>Range</b>	<b>SETUP PARAMETERS Function Blocks</b>
<b>RAISE/LOWER O/P</b> Value of the raise/lower ramp function.	<b>264</b>	—. <b>xx</b> %	<i>Refer to RAISE/LOWER</i>
<b>PID OUTPUT</b> Output of the PID function block.	<b>417</b>	—. <b>xx</b> %	<i>Refer to PID</i>
<b>PID CLAMPED</b> Indicates the PID output has reached either the positive or negative limit.	<b>416</b>	<b>FALSE / TRUE</b>	<i>Refer to PID</i>
<b>PID ERROR</b> Displays the difference between the setpoint (INPUT 1) and the feedback signal (INPUT 2) in the PID function block.	<b>415</b>	—. <b>xx</b> %	<i>Refer to PID</i>
<b>SPT SUM OUTPUT</b> Setpoint summation output.	<b>86</b>	—. <b>xx</b> %	<i>Refer to SETPOINT SUM 1</i>
<b>RAMP OUTPUT</b> Setpoint ramp output.	<b>85</b>	—. <b>xx</b> %	<i>Refer to RAMPS</i>
<b>PRESET O/P</b> Scales the selected preset input by MAX SPEED.	<b>572</b>	—. <b>x</b> %	<i>Refer to PRESET SPEEDS</i>
<b>SRAMP OUTPUT</b> Diagnostic, ramp output.	<b>589</b>	—. <b>x</b> %	<i>Refer to SRAMP</i>
<b>OUTPUT FPM</b> Outputs the selected INPUT value.	<b>593</b>	—. <b>x</b>	<i>Refer to PRESET SPEEDS</i>
<b>SPEED SETPOINT</b> Speed loop total setpoint including the ramp output before the ramp-to-zero function.	<b>63</b>	—. <b>xx</b> %	<i>Refer to SPEED LOOP</i>
<b>TERMINAL VOLTS</b> Scaled armature terminal volts.	<b>57</b>	—. <b>x</b> %	<i>Refer to CALIBRATION</i>
<b>BACK EMF</b> Calculated motor back EMF including IR. compensation. (Armature Volts Feedback)	<b>60</b>	—. <b>x</b> %	<i>Refer to CALIBRATION</i>
<b>ARM VOLTS FBK</b> Back EMF scaled by NOM MOTOR VOLTS (CONFIGURE DRIVE function block).	<b>605</b>	—. <b>V</b>	<i>Refer to FEEDBACKS</i>
<b>TACH INPUT</b> Scaled analog tachogenerator feedback.	<b>308</b>	—. <b>x</b> %	<i>Refer to FEEDBACKS</i>

<b>DIAGNOSTICS (MMI only)</b>			
<b>Parameter</b>	<b>Tag</b>	<b>Range</b>	<b>SETUP PARAMETERS Function Blocks</b>
<b>UNFIL.TACH INPUT</b> Analog tachogenerator feedback (unfiltered).	<b>58</b>	—. <b>x</b> %	<i>Refer to CALIBRATION</i>
<b>ENCODER</b> Encoder speed feedback in RPM.	<b>206</b>	—. <b>.</b> RPM	<i>Refer to ENCODER</i>
<b>UNFIL.ENCODER</b> Encoder speed feedback in RPM (unfiltered).	<b>59</b>	—. <b>.</b> RPM	<i>Refer to ENCODER</i>
<b>UNFIL.SPD.FBK</b> Unfiltered speed feedback.	<b>62</b>	—. <b>xx</b> %	<i>Refer to SPEED LOOP</i>
<b>UNFIL.SPD.ERROR</b> Unfiltered speed error.	<b>64</b>	—. <b>xx</b> %	<i>Refer to SPEED LOOP</i>
<b>CONTACTOR CLOSED</b> Main contactor control signal.	<b>83</b>	<b>FALSE / TRUE</b>	<i>Refer to SEQUENCING</i>
<b>HEALTH LED</b> State of Health LED on Keypad.	<b>122</b>	<b>FALSE / TRUE</b>	<i>Refer to ALARMS</i>
<b>READY</b> The drive is ready to accept an enable signal.	<b>125</b>	<b>FALSE / TRUE</b>	<i>Refer to SEQUENCING</i>
<b>DRIVE RUNNING</b> Drive is enabled and may make current when TRUE. A diagnostic for those parameters that can only be written to when the drive is stopped (parameters marked with Note 2 in the Parameter Specification Table).	<b>376</b>	<b>FALSE / TRUE</b>	<i>Refer to SEQUENCING</i>
<b>SYSTEM RESET</b> Set for one cycle as the drive is enabled.	<b>374</b>	<b>FALSE / TRUE</b>	<i>Refer to SEQUENCING</i>

## SETUP PARAMETERS

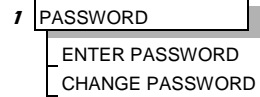
Refer to Appendix D for parameter details. A parameter can be located by referring to the Parameter Specification Table: Tag Number Order.

The layout of this 590+ menu is shown by The Menu System Map on page 6-8.



## 6-16 The Keypad

### MMI Menu Map



## PASSWORD

When in force, the password prevents unauthorised parameter modification by making all parameters “read-only”. If you attempt to modify a password protected parameter, it will cause “PASSWORD ??” to flash on the display.

The password protection is activated/deactivated using the ENTER PASSWORD and CHANGE PASSWORD parameters:

**Activated:** ENTER PASSWORD and CHANGE PASSWORD values are different

**Deactivated:** ENTER PASSWORD and CHANGE PASSWORD values are the same

### To Activate Password Protection

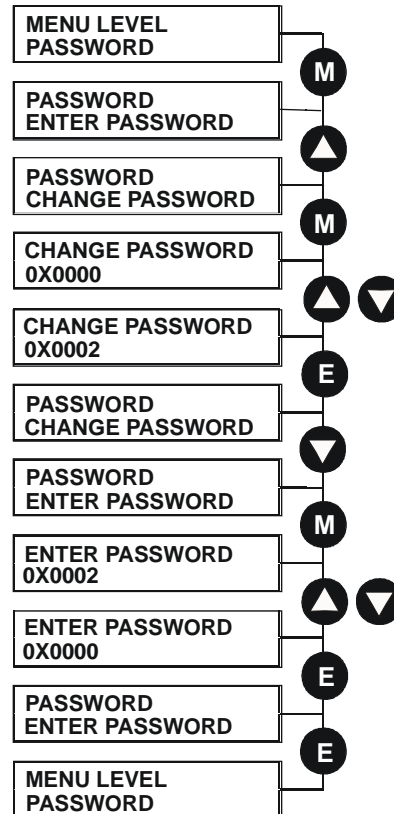
By default, the password feature is disabled, i.e. both the CHANGE PASSWORD and ENTER PASSWORD parameters have the same value: 0x0000.

*To activate a password:*

Enter any value other than the default value (0x0000) in the CHANGE PASSWORD parameter, for example 0x0002.

The ENTER PASSWORD parameter will now display this new password (e.g. 0x0002). Change the value in this parameter (to hide the password).

The password is now hidden, and CHANGE PASSWORD displays “\*\*\*\*”.



### To Deactivate Password Protection

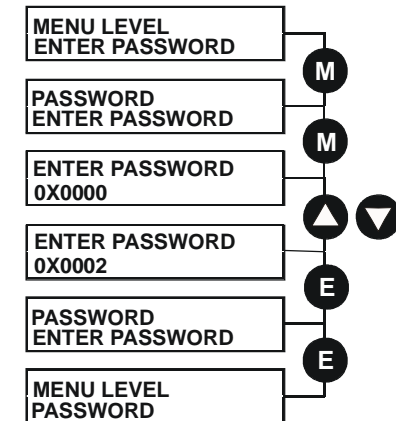
With password protection activated, you can no longer edit the CHANGE PASSWORD parameter until you deactivate the password protection (because the value is hidden by “\*\*\*\*”).

*To deactivate a password:*

Enter the current password (e.g. 0x0002) in the ENTER PASSWORD parameter.

CHANGE PASSWORD will now display the current password.

Because the ENTER PASSWORD parameter value is always reset to 0x0000 when powering-up the drive, 0x0000 is the default value for the CHANGE PASSWORD parameter, i.e. by default, the two parameter values are the same and so password protection is disabled.



## ALARM STATUS

Refer to Chapter 7: "Trips and Fault Finding" for a list of all the alarms.

## MENUS

### Selecting a Menu Viewing Level

For ease of operation the Keypad has three viewing levels: BASIC, STANDARD and ADVANCED. The setting for the viewing level decides how much of the menu system will be displayed.

Refer to the The Menu System Map, page 6-8 to see how the viewing level changes the displayed menu.

To change the viewing level, go to the MENUS menu. The VIEW LEVEL parameter in this menu selects the viewing level.

- Select BASIC to see a reduced selection of parameters to operate the drive
- Select STANDARD to see the "standard" set of parameters
- Select ADVANCED to see the full menu system - useful when programming

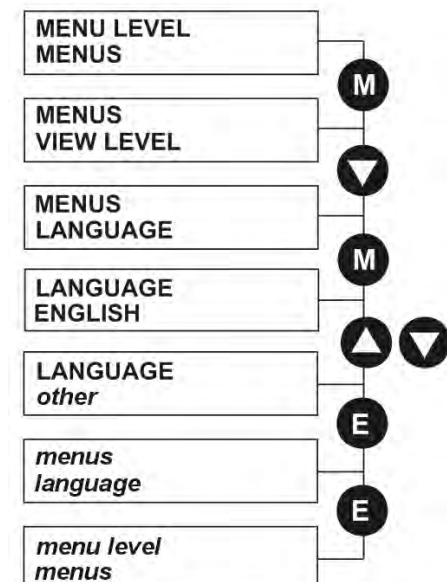
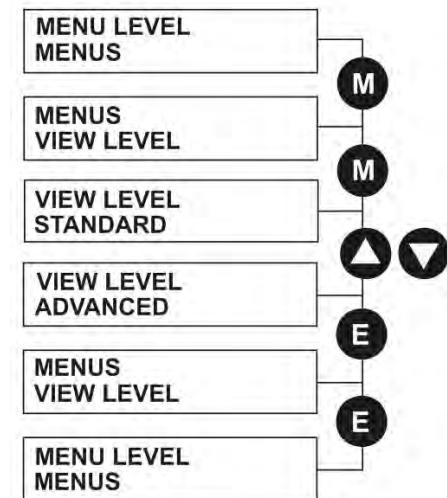
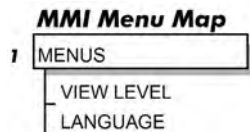
### Selecting the Display Language

There is an option to select a different display language.

The choice of display language is selected by the LANGUAGE parameter in the MENUS menu. Remember to perform a PARAMETER SAVE if you need the new language to be saved on power-down.

ENGLISH is the default language and is permanently saved (in Read Only Memory).

A second language is loaded (typically French), however German, Italian and Spanish are available by contacting Parker SSD Drives. When a new language is downloaded it replaces the current second language.



## 6-18 The Keypad

### SERIAL LINKS

This menu contains 3 function blocks. These can be found in the SETUP PARAMETERS menu - refer to Appendix D: "Programming".

#### SERIAL LINKS

_ TEC OPTION	refer to Appendix D:"Programming"
_ SYSTEM PORT (P3)	refer to Appendix D:"Programming"
_ PNO CONFIG	refer to Appendix D:"Programming"

### SYSTEM

This menu contains 2 parameters and 3 function blocks. The function blocks can be found in the SETUP PARAMETERS menu - refer to Appendix D: "Programming".

#### SYSTEM

_ SOFTWARE	see below
_ CONFIGURE I/O	see below
_ miniLINK	refer to Appendix D:"Programming" - miniLINK
_ SAVE TO OP	refer to Appendix D:"Programming" - CONFIGURE DRIVE
_ LOAD FROM OP	refer to Appendix D:"Programming" - CONFIGURE DRIVE

### SOFTWARE Parameter

This parameter displays the software release of the firmware in the drive.

### CONFIGURE I/O Parameter

This parameter is repeated in several menus. It is used whenever you want to save any changes that are made to a parameter.

Refer to Appendix D: "Programming" - Modifying a Block Diagram.

### PARAMETER SAVE

Refer to "Saving Your Application", page 6-23.

**MMI Menu Map**

1	CONFIGURE DRIVE
	CONFIGURE ENABLE
	NOM MOTOR VOLTS
	ARMATURE CURRENT
	FIELD CURRENT
	FLD. CTRL MODE
	FLD. VOLTS RATIO
	MAIN CURR. LIMIT
	AUTOTUNE
	SPEED FBK SELECT
	ENCODER LINES
	ENCODER RPM
	ENCODER SIGN
	SPD. INT. TIME
	SPD. PROP. GAIN

CONFIGURE DRIVE

The CONFIGURE DRIVE menu contains many of the important parameters used during set-up when using the Keypad.

**NOTE** The FUNCTION BLOCKS\MISCELLANEOUS\CONFIGURE DRIVE menu contains a different set of parameters, for set-up using the configuration tool.

Refer to Chapter 4: "Calibration and Start-Up" - Setting-up the Drive to see the most important parameters being used.

**CONFIGURE DRIVE (MMI view)**

Parameter	Tag	Range	SETUP PARAMETERS Function Blocks
<b>CONFIGURE ENABLE</b> Selects Setup Mode (FALSE) or Configuration Mode (TRUE). Refer to Appendix D "Programming" - Modifying a Block Diagram.	<b>39</b>	<b>FALSE / TRUE</b>	
<b>NOM MOTOR VOLTS</b> Sets the 100% value for Armature Volts VA. Set this value to match the motor in use. (Refer to ARMATURE V CAL in the CALIBRATION function block).	<b>521</b>	<b>100 to 875 VOLTS</b>	
<b>ARMATURE CURRENT</b> Sets the 100% value for Armature Current IA. Set this value to match the motor in use.	<b>523</b>	<b>drive dependent AMPS</b>	
<b>FIELD CURRENT</b> Sets the 100% value for Field Current IF. Set this value to match the motor in use. Note: this should be set to a minimum value if in Field Voltage control - see FLD. CTRL MODE.	<b>524</b>	<b>drive dependent AMPS</b>	
<b>FLD. CTRL MODE</b> Selects between open-loop VOLTAGE CONTROL or closed-loop CURRENT CONTROL.	<b>209</b>	<b>See below</b>	<i>Refer to FIELD CONTROL</i>
<b>FLD. VOLTS RATIO</b> Sets the output dc field voltage as a ratio of the RMS FIELD supply voltage when FLD CTRL MODE is set to VOLTAGE CONTROL.	<b>210</b>	<b>0.0 to 100.0 % (h)</b>	<i>Refer to FIELD CONTROL</i>
<b>MAIN CURR. LIMIT</b> Independent symmetric current clamp. Sets symmetric clamps outside scaling from the CUR. LIMIT/SCALER parameter.	<b>421</b>	<b>0.00 to 200.00 %</b>	<i>Refer to CURRENT LOOP</i>
<b>AUTOTUNE</b> Turns the AUTOTUNE procedure on. Refer to Chapter 4: "Calibration and Start-Up" - Performance Adjustment.	<b>18</b>	<b>OFF/ON</b>	<i>Refer to AUTOTUNE</i>

## 6-20 The Keypad

<b>CONFIGURE DRIVE (MMI view)</b>			
<b>Parameter</b>	<b>Tag</b>	<b>Range</b>	<b>SETUP PARAMETERS Function Blocks</b>
<b>SPEED FBK SELECT</b>	<b>47</b>	<b>See below</b>	
<p>Determines the source of the speed feedback signal. The default, ARM VOLTS FBK, uses internal circuitry to derive the speed feedback. The other selections require the appropriate external device to provide the feedback signal.</p> <p>0 : ARM VOLTS FBK            1 : ANALOG TACH            2 : ENCODER            3 : ENCODER/ANALOG - for Parker SSD Drives use            4 : ENCODER 2</p>			<i>Refer to SPEED LOOP</i>
<b>ENCODER LINES</b>	<b>24</b>	<b>10 to 5000</b>	
<p>The number of lines must be set to match the type of encoder being used. Incorrect setting of this parameter will result in an erroneous speed measurement. The 5901 Microtach has 1000 lines per revolution as standard. Proprietary encoders of other specifications can be normalised by setting this parameter as appropriate.</p>			<i>Refer to ENCODER</i>
<b>ENCODER RPM</b>	<b>22</b>	<b>0 to 6000</b>	
<p>Motor top speed setting (100%) when using encoder feedback.</p>			<i>Refer to ENCODER</i>
<b>ENCODER SIGN</b>	<b>49</b>	<b>NEGATIVE / POSITIVE</b>	
<p>Since the encoder feedback cannot be reversed electrically, the signal polarity can be reversed by the control software.</p> <p><i>It is necessary to set up this parameter when in CLOSED-LOOP VEC mode, as the encoder direction must be correct for this mode to operate.</i></p>			<i>Refer to ENCODER</i>
<b>SPD.INT.TIME</b>	<b>13</b>	<b>0.001 to 30.000 s</b>	
<p>Speed loop PI integral gain adjustment.</p>			<i>Refer to SPEED LOOP</i>
<b>SPD.PROP.GAIN</b>	<b>14</b>	<b>0.00 to 200.00</b>	
<p>Speed loop PI proportional gain adjustment.</p>			<i>Refer to SPEED LOOP</i>

## FUNCTION BLOCKS

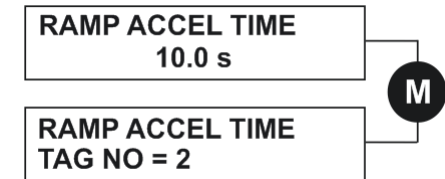
Refer to Appendix D where all the function blocks under this menu are listed in alphabetical order.

This menu repeats all the parameters provided by other menus. The structure of this programmers' menu is the same as the DSELite Configuration Tool.

# Menu Shortcuts and Special Key Combinations

## Quick Tag Information

Hold down the **M** key for approximately ½ second in any Menu System parameter to display the Tag number for that parameter.



## Changing the Stack Size (3-button reset)

**NOTE**

This is only necessary if you are installing a new control board on an existing stack.

Power-up the drive holding three keys as described below.

### Caution

At this point, the 590+ thinks that it is a 34A model. It is vitally important that it is configured for the correct power rating or irreparable damage may occur to the drive when it attempts to run the motor.

Continue to select the correct Product Code rating. Perform a PARAMETER SAVE now (refer to "Saving Your Application", page 6-23).

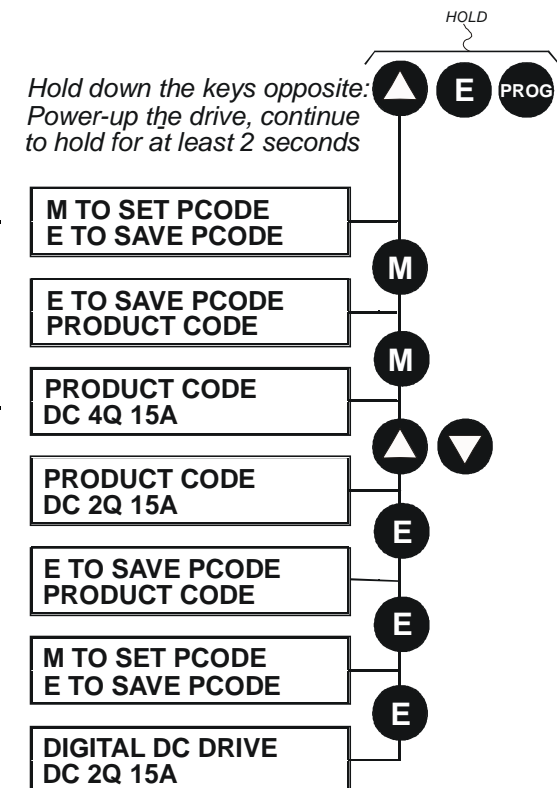
This is the preferred way of selecting a new product code. The available product codes are restricted to the set of codes that match the stack that the control board is fitted to.

If the product code is changed during the 3-button reset, the following parameters are set to their default value for the new product code:

- Tag 523          ARMATURE CURRENT
- Tag 524          FIELD CURRENT
- Tag 201          REGEN ENABLE

**NOTE**

The 3-button reset does not cause the default configuration to be loaded.



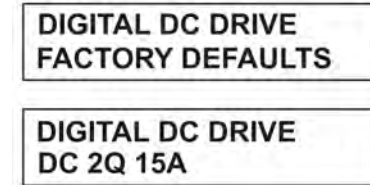
## Resetting to Factory Defaults (2-button reset)

Power-up the drive holding two keys as described below.

The drive is now safely configured with the default settings detailed in this manual for the existing product code.

The default configuration is not automatically saved to non-volatile memory, so you must perform a PARAMETER SAVE (refer to "Saving Your Application", page 6-23).

Hold down the keys opposite: Power-up the drive, continue to hold until the Keypad display illuminates.

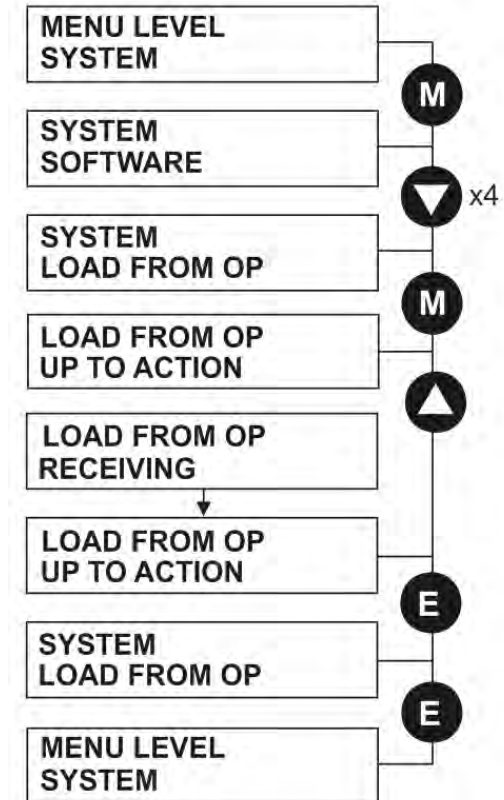
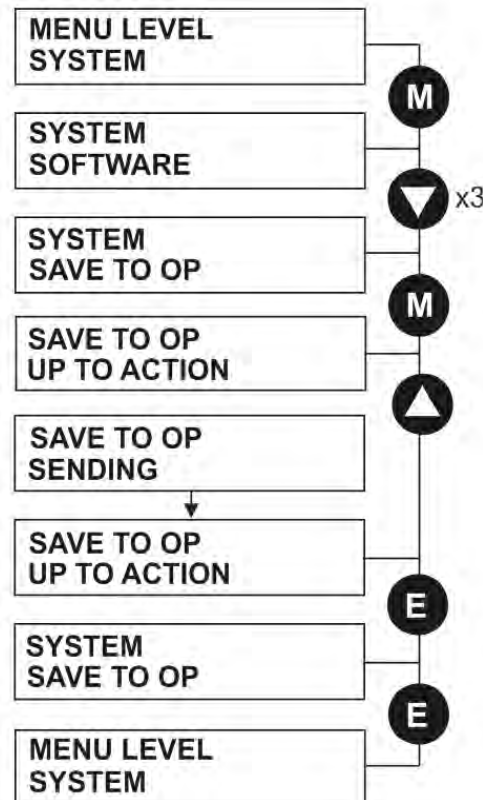


## Cloning Feature

The Keypad can be used to transfer all parameters from a drive to another of the same rating. You can also use the Keypad to store a back-up of the drive's parameter settings.

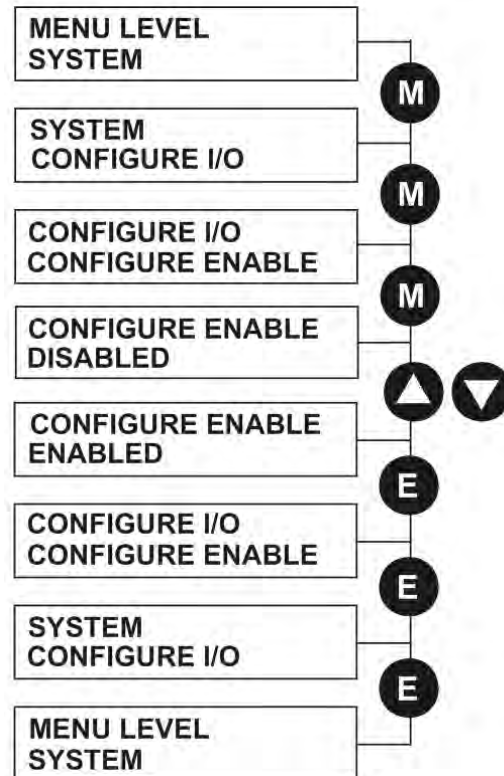
SAVE TO OP will upload all parameter settings from the drive to the Keypad.

LOAD FROM OP will download all parameter settings from the Keypad to the drive.



# How to Save, Restore and Copy your Settings

## Saving Your Application

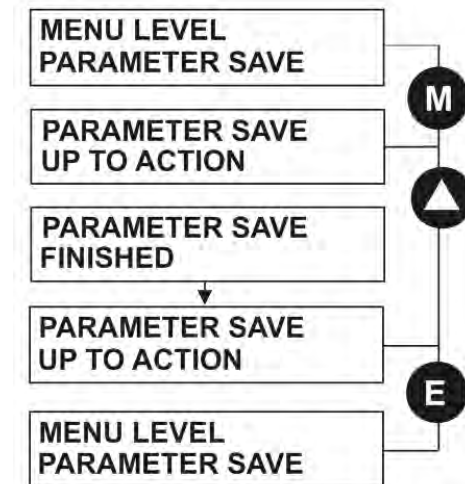


### **Operating Mode (CONFIGURE ENABLE = DISABLED)**

In Operating mode you can change parameter values. The Drive can be running or stopped. Note that some parameters can only be changed when the Drive is stopped. It is not possible to modify the internal links when the Drive is in Operating mode.

### **Configuration Mode (CONFIGURE ENABLE = ENABLED)**

In the configuration mode you can modify connections between the function blocks in the drive. You can also change parameter values, as above. The Drive cannot run in this mode. Output values are not updated.



The PARAMETER SAVE menu, available in both the full and reduced view levels, is used to save any changes you make to the MMI settings.

Pressing the ♦ (UP) key, as instructed, saves all parameter values (with one exception, see the note below) in non-volatile memory, i.e. values are stored during power-down.

**NOTE** The local setpoint parameter value is not saved on power-down.



## 6-24 The Keypad

### **Restoring Saved Settings**

If you are unsure about any changes you have made and you have not yet performed a PARAMETER SAVE, simply switch the Drive off, and power-up again. The “last saved” parameter settings will be restored.

### **Copying an Application**

Copying an application requires a host computer connection to the Drive’s System Port (P3). Information can then be downloaded to the computer (and uploaded to the Drive).

Refer to Appendix A: “Serial Communications” for further information.

# Chapter 7 Trips and Fault Finding

The drive may trip in order to protect itself. To restart the drive, you will need to clear the trip(s). This chapter provides a list of trips, as displayed by the keypad

## Trips and Fault Finding

- Trips

What Happens when a Trip Occurs

## Fault Finding

Initial Troubleshooting Procedure

Calibration Checks

Alarm Messages

Hexadecimal Representation of Trips

Power Board LED Trip Information (Frame 4, 5, 6 & 7)

- Using the Keypad to Manage Trips
- Hardware Troubleshooting

Control Power Missing

Field Fail Procedure

Contactors Failed Procedure

SCR Troubleshooting

Motor Checks

- Common Performance Problems
- Test Points



# Trips and Fault Finding

---

## Trips

### What Happens when a Trip Occurs

When a trip occurs, the Drive's power stage is immediately disabled causing the motor and load to coast to a stop. The trip is latched until action is taken to reset it. This ensures that trips due to transient conditions are captured and the Drive is disabled, even when the original cause of the trip is no longer present.

### Drive Indications

If a trip condition is detected the unit displays and performs the following actions.

1. The HEALTH LED goes out indicating a Trip condition has occurred. (Investigate, find and remove the cause of the trip).
2. Terminal B6 (Healthy) goes low (0V).

### Keypad Indications

If a trip condition is detected the MMI displays and performs the following actions.

1. The HEALTH LED goes out indicating a Trip condition has occurred. The MMI displays the activated alarm. (Investigate, find and remove the cause of the trip.)
2. The alarm message(s) can be acknowledged by pressing the **E** key, however, the unit will not restart at this point.
3. If using Serial Comms, xxx PARM >0000.

### Resetting a Trip Condition

All trips must be reset before the Drive can be re-enabled. A trip can only be reset once the trip condition is no longer active, i.e. a trip due to a heatsink over-temperature will not reset until the temperature is below the trip level.

**NOTE** More than one trip can be active at any time. For example, it is possible for both the HEATSINK TRIP and the OVERVOLTS (VA) trips to be active. Alternatively it is possible for the Drive to trip due to a FIELD OVER I error and then for the HEATSINK TRIP trip to become active after the Drive has stopped (this may occur due to the thermal time constant of the heatsink).

You can reset the trip(s) in one of two ways:

1. Power-up, or remove and re-apply the auxiliary power supply.
2. Stop and start the drive, i.e. remove and re-apply the Start/Run signal (terminal C3 or C4, or the STOP and RUN keys on the MMI).

Success is indicated by the HEALTH LED (on the unit or MMI) illuminating. The MMI will return to its original display.

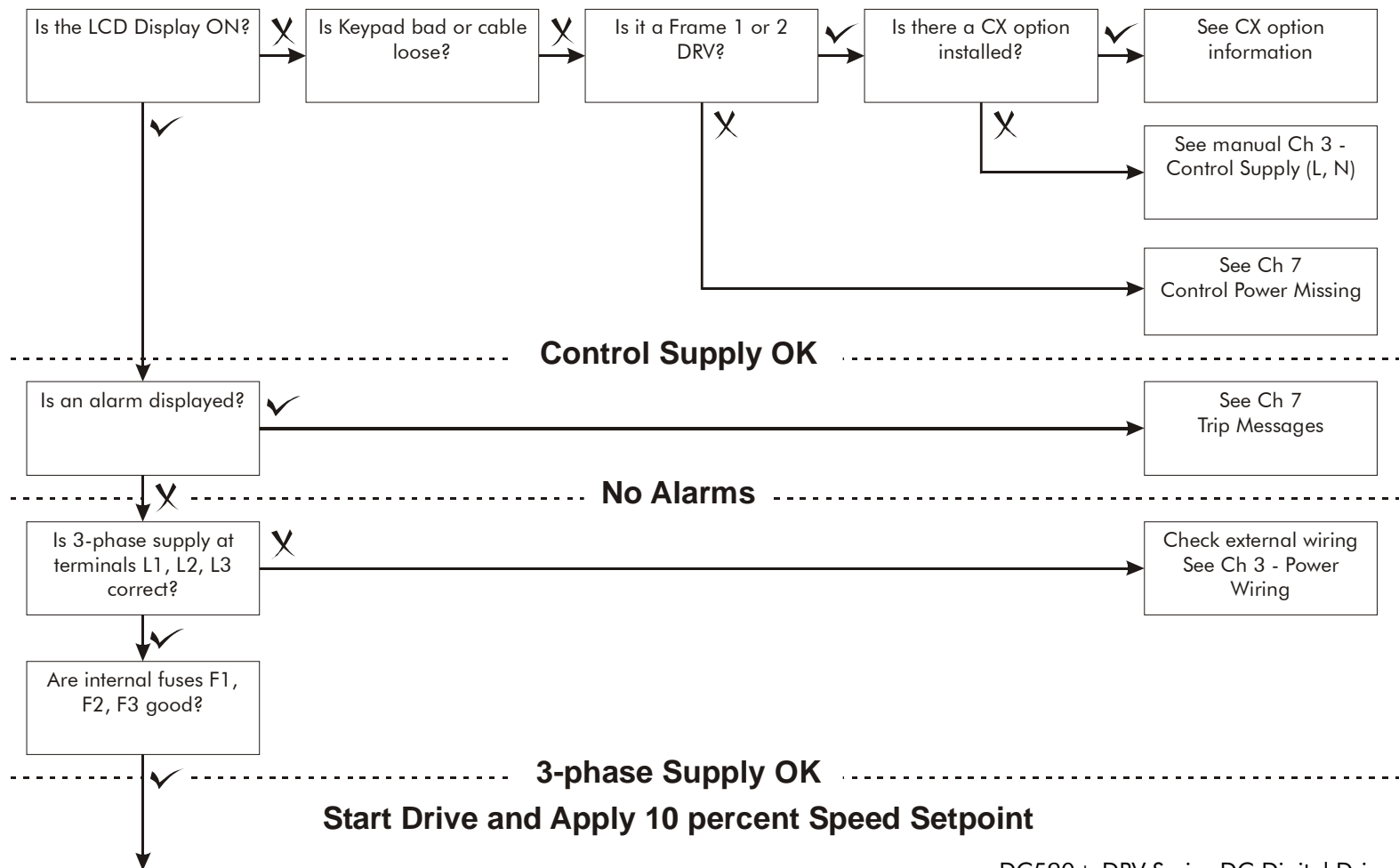
# Fault Finding

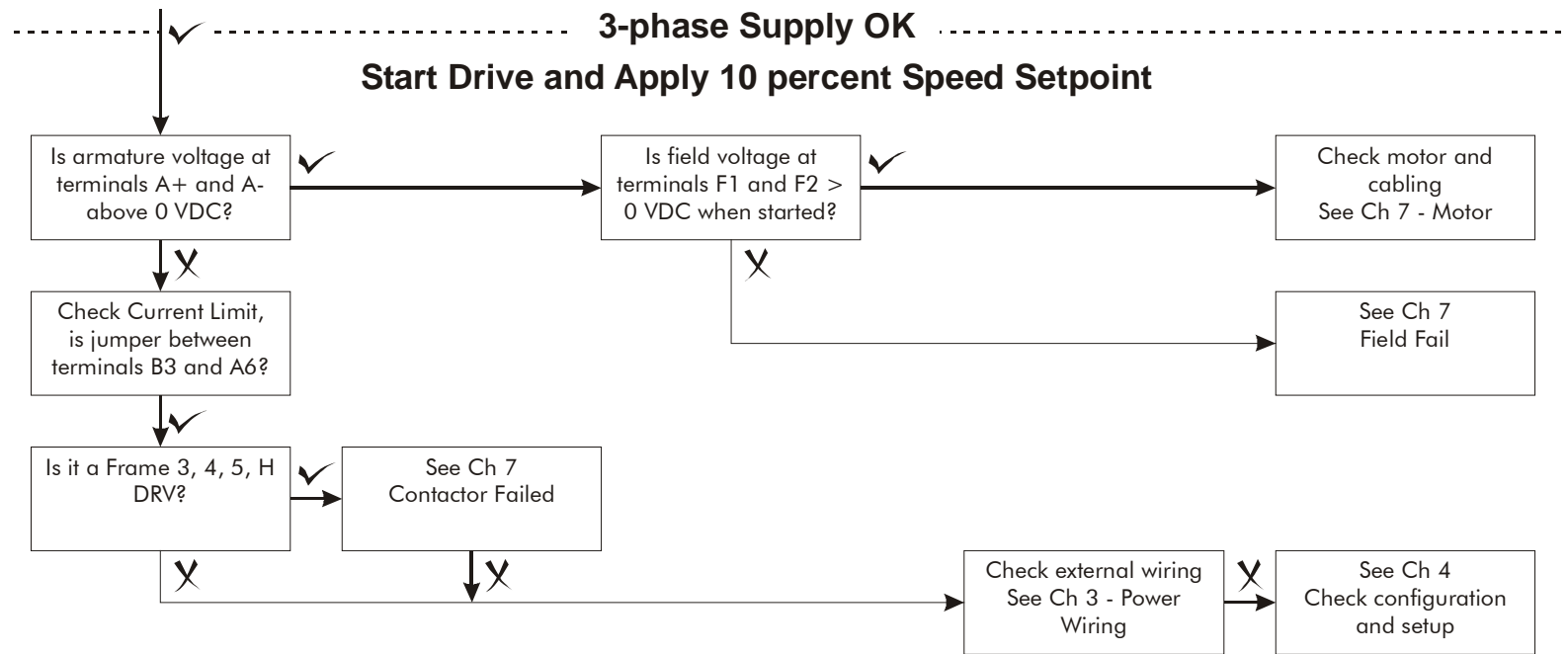
The most valuable tools for finding and resolving faults are the keypad LEDs and display. You can also monitor alarms and troubleshoot faults remotely through a computer interface if a communications Techbox is installed in the drive.

## Initial Troubleshooting Procedure

Most drive problems are encountered during commissioning or soon after start-up. Problems frequently result from incorrect installation or errors in configuring the drive. If you encounter a problem upon initial start-up of the DRV, see the flowchart below and review the installation procedures in Chapter 3 and the start-up and adjustment procedures in Chapter 4.

If you have reviewed these procedures and all seems to be in order, refer to Hardware Troubleshooting in this chapter.





**Figure 7-1 Initial Troubleshooting Procedures**

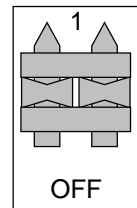
## Calibration Checks

The drive leaves the factory with the following calibration switches correctly set. Inappropriate settings will prevent the drive from operating correctly. For your reference, the correct settings are given below.

**IMPORTANT** *If you change the settings for any of these switches you MUST re-calibrate the Control Board. Refer to Chapter 4: "Calibration and Startup" - Calibrating the Control Board.*

### Control Board Calibration

The control board calibration scaling switch of previous DC590+ products (shown opposite) has been replaced by a software-controlled scaling function. There are no user settings required.



### Power Board Current Calibration Switches (Frame 2)

**NO POWER IS CONNECTED AT THIS STAGE**

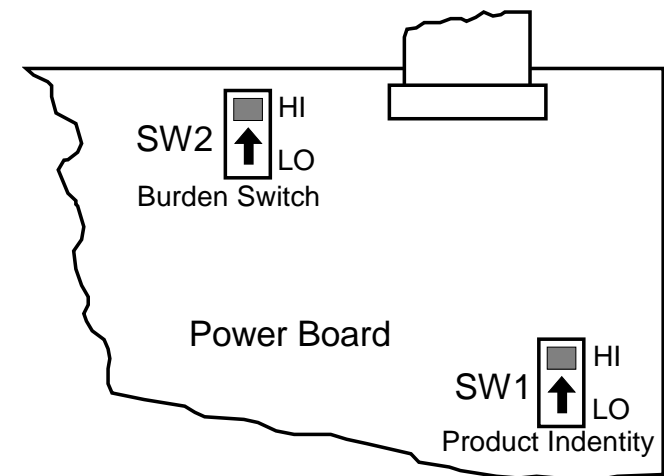
View the switches with the drive door open:

#### **SW1 - Product Identity Switch**

This switch is always set to HI.

#### **SW2 - Burden Switch**

This switch is always set to HI.



## Adaptor Board Current Calibration Switch (Frame 3)

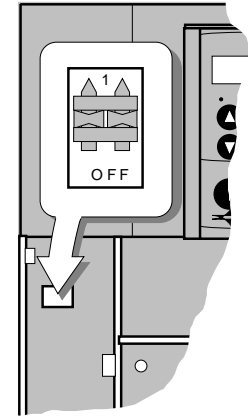
**NO POWER IS CONNECTED AT THIS STAGE**

View the switch with the terminal cover removed:

### *IA CAL - Armature Current Calibration Switch*

This switch should be set to "1" (ON) for armature current scaling greater than 128A.  
Set to OFF for other values.

**NOTE** This switch must only be operated with the drive powered-down.



## Power Board Current Calibration Switches (Frames 4 & 5)

**NO POWER IS CONNECTED AT THIS STAGE**

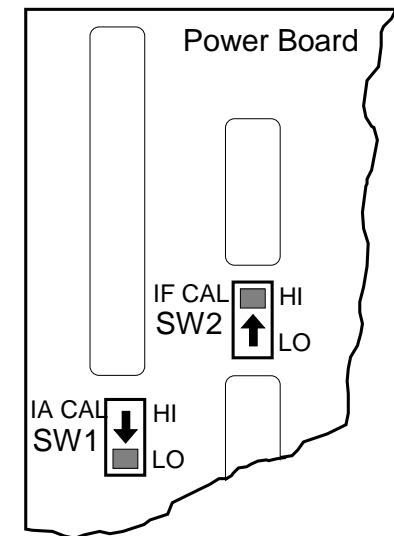
View the switches with the drive door open:

### *IA CAL – Armature Current Calibration Switch (SW1)*

This switch is always set to LO on Frame 4 & 5 drives of 500A or less, and HI for drives greater than 500A.

### *IF CAL – Field Current Calibration Switch (SW2)*

This switch is always set to HI for Frame 4 & 5 drives. The maximum field current calibration is 30A.

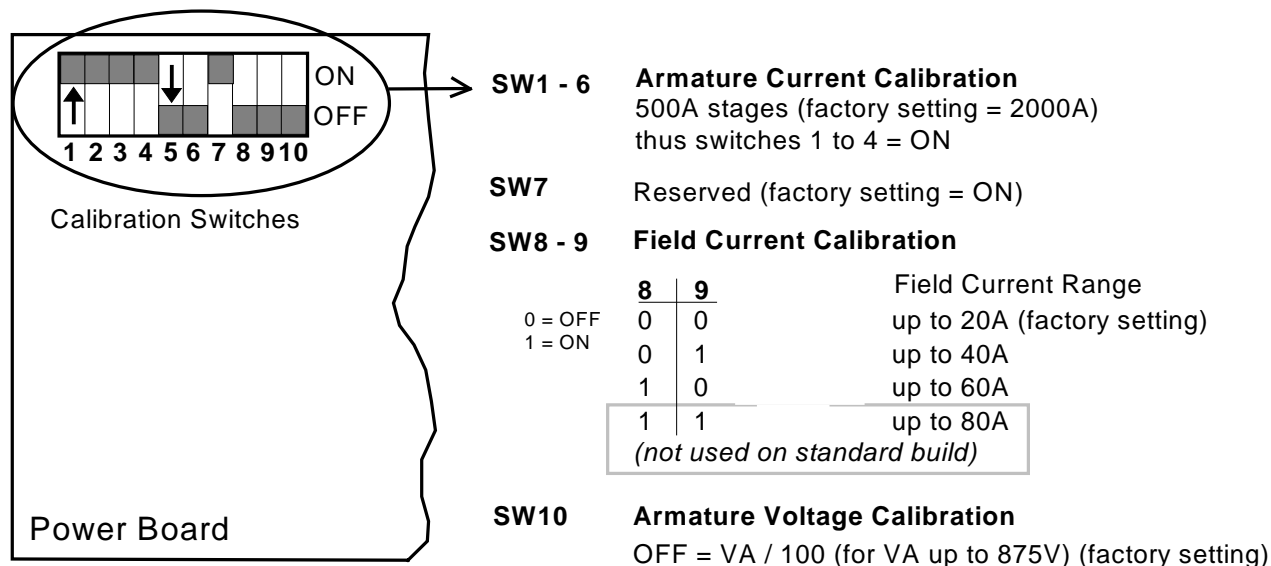




## Power Board Current Calibration Switches (Frames 6 & H)

**NO POWER IS CONNECTED AT THIS STAGE**

To access the power board remove the terminal cover, unscrew the two fixings on the right hand side of the control door. Open the door to reveal the power board.



**Figure 7-1 Calibration Switches**

### ***IA CAL - Armature Current***

Calibration switches 1 to 4 are always set to “ON”, and 5 to 6 are always set to “OFF”.

### ***Armature Voltage***

Calibration switch SW10 is always set to "OFF".

### ***IF CAL - Field Current***

For field currents greater than 20A, set the Field Current calibration switches 8 and 9 to give the required Field Current range. The drive’s Product Code includes the value for Field Current. If you change the Field Current from the 20A factory setting to another value, you must now select the correct Product Code rating:

**AUXILIARY POWER ONLY IS CONNECTED AT THIS STAGE**

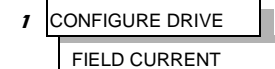
Apply auxiliary power. Note the current Product Code which is displayed on the MMI's Welcome screen at the top of the menu, e.g. DC 4Q 1700A **20** D (**20** = 20A Field Current range)

*Set the following parameters, but first select CONFIGURE ENABLE to be ENABLED.*

Now, for instance, to set the Field Current range for 40A, you must select the appropriate Product Code for a Field Current range of 40A, e.g. DC 4Q 1700A **40** D

To do this, refer to Chapter 6: "The Keypad" – Changing the Stack Size (3-button reset).

Note the nominal field current from the motor rating plate and set this value in the FIELD CURRENT parameter.

**MMI Menu Map**

*Now select CONFIGURE ENABLE to be DISABLED and perform a PARAMETER SAVE.*

*You MUST re-calibrate the Control Board.*

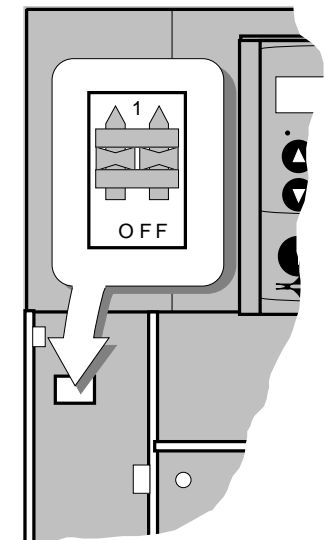
*Refer to Chapter 4: "Calibration and Start up" - Calibrating the Control Board.*

**Adaptor Board Current Calibration Switch (Frames 6 & H)****NO POWER IS CONNECTED AT THIS STAGE**

View the switch with the terminal cover removed:

**IA CAL - Armature Current Calibration Switch**

This switch is always set to "1" (ON).



## Alarm Messages

The drive continuously monitors alarms whilst running. These alarms are gated together to provide an overall "drive healthy" logic variable. This variable corresponds to the ALARM STATUS software block output HEALTHY (tag number 122). By default the HEALTHY logic parameter is tagged to terminal B6 (DIGOUT 2).

When a trip occurs an alarm message is displayed on the MMI, and information about the trip is stored in the ALARM STATUS menu.

The alarm message and the LAST ALARM parameter are displayed in the selected language when viewed on the MMI.

The HEALTH STORE, HEALTH WORD and ALARM HISTORY parameters display information as hexadecimal values, or the sum of the hexadecimal values when more than one alarm is active. Thus the unique value can represent one or more alarms.

**NOTE** Hexadecimal refers to the common practice of counting to the base of 16 in computing rather than the base of 10. The sixteen 'numbers' used being 0 to 9, A to F. Thus an 8 bit byte is represented by two characters in the range 00 to FF, while a 16 bit word is represented by four characters in the range 0000 to FFFF.

### LAST ALARM

(Tag 528). This display shows the last alarm message to have been displayed. To reset the parameter simply press the ↓ (DOWN) key to clear the alarm. Alternatively, you can switch the auxiliary supply off and on, causing NO ACTIVE ALARMS to be displayed.

**NOTE** The LAST ALARM value is presented in hexadecimal format when viewed in DSELite or when used in the Block Diagram.

### HEALTH WORD

(Tag 115). This parameter is used to continuously monitor the status of the Drive. As alarms are added or removed, the display will immediately update to show the hexadecimal sum of these alarms.

The value reverts to 0x0000 when the Start (C3) input is raised (+24V), and when no trip condition is present.

### HEALTH STORE

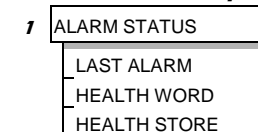
(Tag 116). This displays the hexadecimal value of the first (or only) alarm to occur causing the trip condition.

The display reverts to 0x0000 when the Start (C3) input is raised (+24V).

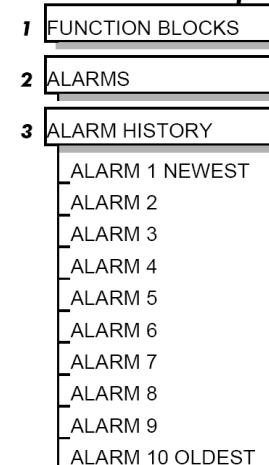
### ALARM HISTORY

The most recent 10 alarm events are stored in the ALARM HISTORY function block, with the oldest in parameter ALARM 10 (OLDEST), and most recent in ALARM 1 (NEWEST). As with the HEALTH STORE and HEALTH WORD parameters, the alarm history is stored as four character hexadecimal numbers.

#### MMI Menu Map



#### MMI Menu Map



## Hexadecimal Representation of Trips

The LAST ALARM, HEALTH WORD, HEALTH STORE and ALARM HISTORY parameters use a four digit hexadecimal number to identify individual trips. Each trip has a unique corresponding number as shown below.

LAST ALARM, HEALTH WORD and HEALTH STORE				
Trip		Trip Code		
		First Digit	Digit	Last Digit
	NO ACTIVE ALARMS			
0	OVERSPEED			1
1	MISSING PULSE			2
2	FIELD OVER I			4
3	HEATSINK TRIP			8
4	THERMISTOR		1	
5	OVER VOLTS (VA)		2	
6	SPD FEEDBACK		4	
7	ENCODER FAILED		8	
8	FIELD FAILED	1		
9	3 PHASE FAILED	2		
10	PHASE LOCK	4		
11	5703 RCV ERROR	8		
12	STALL TRIP	1		
13	OVER I TRIP	2		
14	OTHER •	4		
15	ACCTS FAILED	8		

• For the LAST ALARM parameter, replace OTHER with trip codes opposite.

Trip Codes : LAST ALARM only			
14	AUTOTUNE ERROR	F 0 0 1	
14	AUTOTUNE ABORTED	F 0 0 2	
14	SEQ PRE READY	F 0 0 3	
14	CONTACTOR DELAY	F 0 0 4	
14	EXTERNAL TRIP	F 0 0 5	
14	REMOTE TRIP	F 0 0 6	
14	ENABLE LOW	F 0 0 7	
14	SEQUENCING	F 0 0 9	
14	COMMS TIMEOUT	F 0 1 0	
14	CONFIG ENABLED	F 2 0 0	
14	CALIBRATION TRIP	F 3 0 0	
14	NO OP-STATION	F 4 0 0	
14	AUX SUPPLY	F F 0 3	

## 7-10 Trips and Fault Finding

When more than one trip is to be represented at the same time then the trip codes are simply added together to form the value displayed. Within each digit, values between 10 and 15 are displayed as letters A to F

For example, if the HEALTH WORD parameter is **01A8** then this represents a “1” in digit 3, an “8” and a “2” in digit 2, (8+2 = 10, displayed as A) and an 8 in digit 1. This in turn represents the active trips FIELD FAILED, ENCODER FAILED, OVER VOLTS (VA) and HEATSINK TRIP (an unlikely situation).

Decimal number	Display
10	A
11	B
12	C
13	D
14	E
15	F

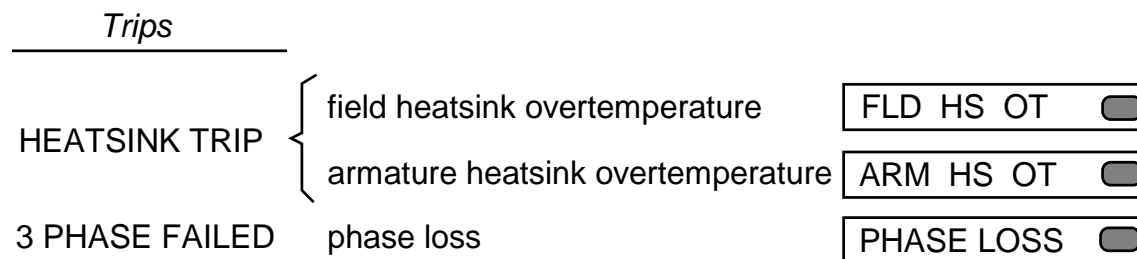
### Power Board LED Trip Information (Frame 4, 5, 6 & 7)

The HEATSINK TRIP, 3 PHASE FAILED and ACCTS FAILED trips are associated with the following LED indications:

#### Frame 4

Check the LEDs on the power board for more HEATSINK TRIP information.

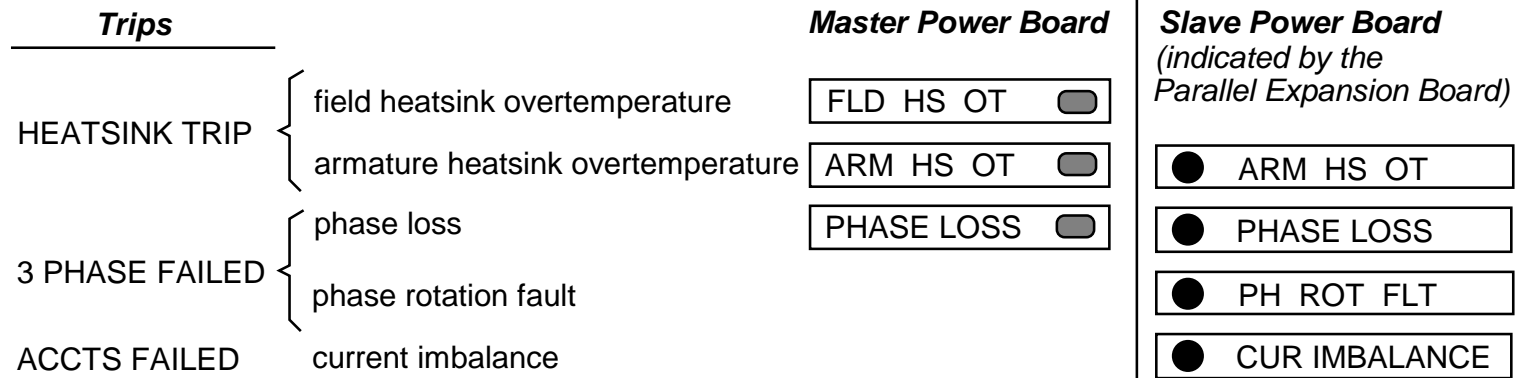
The LEDs light to indicate a problem.



**Frame 5**

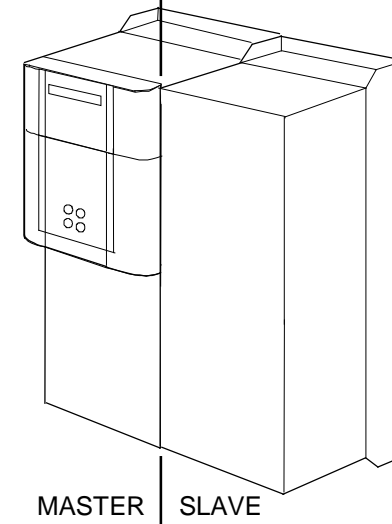
The master power board (on the left hand side of the unit) is fitted with a Parallel Expansion Board. This board has four additional LEDs providing information about the slave power board (on the right hand side of the unit), and about the general status of the unit.

The LEDs light to indicate a problem.



It is essential that the phase sequence applied to the two stacks are identical otherwise the converter will trip on 3 PHASE FAILED.

If there is a current imbalance between the stacks which exceeds 10% the converter will trip on ACCTS FAILED.



## 7-12 Trips and Fault Finding

### Frame 6

Eight diagnostic LEDs indicate further trip information, and general status of the unit. The LEDs go out to indicate a problem (note that LED1 may also flash as the SMPS attempts to power-up repeatedly, indicating a fault).

Trips		Power Board	
	switched mode power supply on	SMPS OK	● LED1
ACCTS FAILED	trigger board connection status	TRIGGER BOARD PRESENT	● LED9
	ac current transformer connection status	ACCTS PRESENT	● LED10
3 PHASE FAILED	thyristor fuses status	THYRISTOR FUSES	● LED11
HEATSINK TRIP	field heatsink temperature normal	FIELD THERMOSTAT	● LED12
	L1 Phase Assembly heatsink temperature normal	L1 STACK THERMOSTAT	● LED13
	L2 Phase Assembly heatsink temperature normal	L2 STACK THERMOSTAT	● LED14
	L3 Phase Assembly heatsink temperature normal	L3 STACK THERMOSTAT	● LED15
	Fans stalled	L* FAN	● Fan LEDS

\* In the event of a trip due to a stalled fan, an unlit fan LED will indicate the failed fan. With the drive stopped, operate the fan fail override switch and restart the drive. Diagnose the failed fan from the fan LEDs status.

**Frame 7**

The power board has six LEDs indicating further trip information, and general status of the unit.

The LEDs go out to indicate a problem (note that LED1 may also flash as the SMPS attempts to power-up repeatedly, indicating a fault).

<u><b>Trips</b></u>		<b>Power Board</b>	
	switched mode power supply on	SMPS OK	<input type="checkbox"/> LED1
ACCTS FAILED	{ trigger board connection status	TRIGGER BOARD PRESENT	<input type="checkbox"/> LED4
	{ ac current transformer connection status	ACCTS PRESENT	<input type="checkbox"/> LED3
3 PHASE FAILED	thyristor fuses status	THYRISTOR FUSES	<input type="checkbox"/> LED6
HEATSINK TRIP	{ field heatsink temperature normal	FIELD HEATSINK	<input type="checkbox"/> LED2
	{ armature heatsink temperature normal	STACK THERMOSTATS	<input type="checkbox"/> LED5



## Using the Keypad to Manage Trips

### Trip Messages

Most of the alarms have a delay timer so that the Drive only trips if the condition persists for the whole of the delay period.

If the Drive trips, then the display immediately shows a message indicating the reason for the trip. The possible trip messages are given in the table below.

Trip Message and Meaning	Possible Reason for Trip	Corrective Action
<b>OVERSPEED</b> Motor overspeed - the speed feedback signal has exceeded 125% of rated speed. Alarm time delay: 50ms	Improperly set maximum speed parameters	Use hand tachometer to ensure proper speed and adjust the speed calibration parameter
	Wrong type of feedback selected in SPEED FBK SELECT parameter in MMI	Change parameter to match feedback type
	Calibration set incorrectly on Analog Tachometer Calibration Option Board	Verify calibration setting
	Improper calibration of drive speed feedback, encoder ppr selection for example	Recalibrate the speed feedback
	Improper tuning of speed loop parameters - drive overshooting or unstable	Retune drive speed loop
	Coupling between motor and feedback device slipping	Stop drive and isolate power - check tightness of coupling
	Feedback device noisy or defective	Replace tachometer generator
	Bottom two LEDs on the 5701 Microtach receiver board are out	Weak feedback signal intensity; check connections, fiber optic wire integrity, and transmission distances
	Field weakening parameters incorrectly set	Reconfigure the field weakening parameters as described in Chapter 4.
	Drive operating as current regulator	Check external speed loop adjustments
<b>MISSING PULSE</b> A missing pulse from the 6-pulse armature current waveform. Trips when the motor loading exceeds 1.5 times the DISCONTINUOUS parameter value.	Drive not Autotuned (unstable current loop)	Perform the AUTOTUNE procedure
	SCR gate connection loose	Check SCR gate connections from the trigger board to the SCR gate leads
	SCR defective	Check SCRs with an ohmmeter. See SCR Troubleshooting, page 7-27

Trip Message and Meaning	Possible Reason for Trip	Corrective Action
Alarm time delay : 60 seconds <b>Note that the MISSING PULSE trip is not intended or able to protect the drive if a thyristor fails to function during regenerative operation. This can result in damage to the drive.</b> We recommend fusing the armature circuit if regenerative operation is intended. The MISSING PULSE trip is intended to detect firing circuit problems during motoring operation of the drive. <b>NOTE</b> Ripple from the speed loop from either the setpoint or feedback can cause unstable current	SCR firing pcb defective	Replace the pcb
	Motor has opened or shorted coil	Check the motor with an ohmmeter and megger for insulation and continuity
	Coupling between motor and feedback device slipping	Stop drive and isolate power - check coupling tightness
	Feedback device noisy or defective	Replace tachometer generator if noise is present while observing feedback with an oscilloscope
	Bottom two LEDs on the 5701 Microtach receiver board are out	Weak feedback signal intensity; check connections, fiber optic wire integrity, and transmission distances
	Speed loop gain too high	Retune drive speed loop
<b>FIELD OVER I</b>	Regulator failure	Contact Product Support
The motor field current has exceeded 120% of the calibrated value Alarm time delay : 10 seconds	Badly tuned control loop (alarm only operates with field current control mode selected)	Retune control loop
<b>HEATSINK TRIP</b>	The ambient air temperature is too high	Check cooling, ambient air temperature must not exceed 40°C (104°F) for full rating
The drive heatsink temperature is too high Alarm time delay : 0.5 seconds	Poor ventilation or spacing between drives	Improve ventilation, if necessary reposition drives ensuring correct spacing
	Fan failure	Check fuse on power board, wrong rotation (models above 70A bridge rating)
<b>NOTE</b> The stack must be allowed to cool in order to re-start the drive.	Blocked ventilation slots	Clear ventilation slots
	Clogged air filters	Clean or replace air filters
	Excessive armature current	Check nominal armature current on motor nameplate against the current calibration for the drive
<b>THERMISTOR</b>	Motor thermal protection device not wired to drive or thermistor/thermostat open circuited	Check TH1 to TH2 connections to drive - connect TH1 to TH2 if motor not fitted with a thermal protection device (thermistor/thermostat)
The motor temperature is too high Motor thermistor/thermostat input open or high impedance Alarm time delay : 5 seconds	Blower motor rotating in wrong direction (force ventilated motors)	Check direction of fan agrees with arrow on motor blower motor assembly or motor manual
	Blower filter clogged	Clean or replace filter

## 7-16 Trips and Fault Finding

Trip Message and Meaning	Possible Reason for Trip	Corrective Action
<b>NOTE</b> The motor must be allowed to cool in order to re-start the drive.	Blower motor starter tripped	Blower Motor Protector Option (if fitted) : remove the fault and press the Start button on the Option to reset
	Motor operating at low speed/high current	TEFC motors do not generate sufficient flow of air to provide sustained full load at low speed. Check gearing and/or reduce mechanical load. Use a higher power motor or provide additional cooling method independent of motor RPM
	Drive miscalibrated	Check motor armature and current calibration matches motor nameplate information
	Field miswired	Check motor field wiring matches motor wiring diagram for field supply
<b>OVER VOLTS (VA)</b> Motor armature voltage has exceeded 120% of rated volts Alarm time delay : 1 second	Drive miscalibrated for motor armature voltage	Check armature voltage calibration matches motor nameplate information
	Drive miscalibrated for field voltage ratio (voltage model) or field current (current or field weakening model)	Check field calibration of drive. Check field current not exceeding motor nameplate data
	Armature open circuit	Check armature wiring. Check armature fuse F7 (regenerative units only)
	Motor maximum speed set incorrectly causing armature voltage to exceed nameplate rating	Change maximum speed parameter to match the nameplate rating
	Field weakening parameters set incorrectly if using an extended speed range motor	Change field weakening parameters for use with an extended speed range motor - refer to Chapter 4.

Trip Message and Meaning	Possible Reason for Trip	Corrective Action
<p><b>SPEED FEEDBACK</b>            The difference between speed feedback and armature voltage feedback is greater than the SPDFBK ALM LEVEL parameter value            If FLD WEAK ENABLE parameter is enabled, speed feedback is less than 10% when in the field weakening region            Alarm time delay : 0.125 seconds</p>	Analog tachometer feedback polarity incorrect (terminals G3 and G4)	Reverse tachometer leads, or swap encoder connections
	Armature volts miscalibrated	Check armature voltage calibration setting, Chapter 4.
	Tachometer generator miscalibrated	Check Analog Tachometer Calibration Option Board setting are for the proper feedback voltage at motor top speed
	Armature voltage sensing leads miswired or damaged	Check wiring of armature voltage sensing wires AS+, AS- from DC contactor to power supply board
	Coupling between motor and feedback device slipping	Stop drive and isolate power - check tightness of coupling
	Feedback device noisy or defective	Replace tachometer generator if noise is present while observing feedback with an oscilloscope
	Bottom two LEDs on the 5701 Microtach receiver board are out	Weak feedback signal intensity; check connections, fiber optic wire integrity, and transmission distances
	Motor has opened or shorted coils	Check the motor for insulation continuity
	Analog tachometer feedback wires or shield loose or shorted to ground	Reconnect the wiring
<p><b>ENCODER FAILED</b>            No speed feedback signal</p>	Optional Encoder board is not fitted	The SPEED FBK SELECT parameter is set to ENCODER but board not fitted
	Wire-ended encoder wires loose	Check cable and connections
	Microtach encoder wires loose or damaged	Check fibre optic cable for damage, bend radius, operating length - refer to Microtach handbook.

## 7-18 Trips and Fault Finding

Trip Message and Meaning	Possible Reason for Trip	Corrective Action
<b>FIELD FAIL</b> Field current is less than 6% of rated current when in Current Control mode Field current is less than 50mA when in Voltage Control mode (with default current burden of 15K) Alarm time delay : 1 second Refer to Field Fail Procedure, page 7-25	Open circuit motor field	Check connection and measure field resistance
	Faulty operation of field controller	Where an ac supply feeds the onboard field regulator, check connections FL1 & FL2 for line-to-line voltage (rather than line-to-neutral) - L1 into FL1, L2 into FL2. The 3-phase supply must be present for mains synchronisation purposes
	No field supply required	For loads where no field supply is required, e.g. a permanent magnet motor, set the FIELD ENABLE parameter to disable to suspend this alarm.
<b>3-PHASE FAILED</b> 3-phase supply failure	Mains voltage incorrect	Check the mains voltage of the drive (refer to Product Code). This alarm may not operate properly if the voltage is incorrect, i.e. wrong unit or drive
	Supply voltage low or missing	Check auxiliary/control or main supply power
	Blown fuse	Check external branch circuit protection. Check auxiliary/control fuse F1 Check that armature current calibration does not exceed drive rating
	Loose wiring. AC contactor not engaging	Check all power wiring for tightness
	Defective power supply pcb	Replace power supply pcb
<b>PHASE LOCK</b> Drive SCR firing phase lock loop unable to lock to supply waveform	One or more phase of supply low, too high or missing	Check all three phases of the supply, other equipment on the same supply may be unbalancing the phases. Check fuses F1, F2, F3, FS4, FS5 and FS6
	Supply waveform badly distorted	Install line chokes and/or isolation transformers if not present with drive
	Power supply pcb or control door defective	Replace the power supply board
	Supply frequency outside 46-65Hz range	Change supply for one within the 45 to 65Hz range

Trip Message and Meaning	Possible Reason for Trip	Corrective Action
<b>5703 RCV ERROR</b> Invalid data received via P3 port from another drive/external 5703 unit when configures as a slave device (Alarm only operates when MODE parameter is set to 5703 SLAVE)	Cable from drive/5703 unit not plugged into drive P3 port	Check connection from drive/5703 unit to drive P3 port on control door
	5703 unit not receiving communications from master device	Check output connections and operation of master 5703 unit
	Drive incorrectly configured	Check configuration
	5703 peer-to-peer communications module failure	Replace 5703
<b>STALL TRIP</b> With motor stationary (AT ZERO SPEED parameter shows TRUE), current has exceeded the STALL THRESHOLD parameter value for longer than the STALL TRIP DELAY parameter value (Alarm only operates when the STALL TRIP parameter is enabled).	Stall timer set too short for load acceleration	Increase stall trip delay and/or install trip threshold if STALL TRIP is being used
	Field current below motor nameplate rating (if the drive is in field current control mode)	Confirm motor field current with DC clamp on meter or current meter. Check drive field calibration
	Field connection miswired	Check motor field wiring is in accordance to motor prints
	Motor unable to deliver sufficient torque	Check motor not undersized for load requirements
	Mechanical binding of the motor	Check for mechanical problems which may cause motor to stall
	Field voltage is not set correctly (if the drive is in field voltage control mode)	Adjust the FLD.VOLTS RATIO parameter in the Calibration section, Chapter 4.
<b>OVER I TRIP</b> Armature overcurrent trip. Armature current has exceeded 280% of calibration value <b>NOTE 300% loading not exceeding 15ms or 325% not exceeding 6.6ms is acceptable)</b>	Drive not Autotuned (unstable current loop)	The drive AUTOTUNE procedure <b>MUST</b> be followed for the motor the drive is to control. Repeat the AUTOTUNE procedure
	Drive incorrectly calibrated	Check the calibration settings
	Manual tuning of the drive leaves current loop unstable (THIS IS NOT RECOMMENDED!)	Current loop response may be manually adjusted only <b>AFTER</b> AUTOTUNING is complete. Check current loop response.
	Coupling between motor and feedback device slipping	Stop drive and isolate. Check coupling tightness
	Motor armature faulty	Check motor resistance to ground. Check for armature shorts
	Loss of main supply during regeneration	Check main supply branch circuit protection and SCR fuses (if existing)
	Control Door or Power Supply PCB faulty	Replace defective board

## 7-20 Trips and Fault Finding

Trip Message and Meaning	Possible Reason for Trip	Corrective Action
<b>ACCTS FAILED</b> <b>The trip prevents the contactor closing and the current loop activating without armature current feedback - important in the case of external stack drives where the thyristor stack is remote from the control board.</b>	AC current transformer plug connection to drive power board missing	Check armature current transformer plug for correct installation.
	Frame 5 only:	Load imbalance between the two parallel power stacks
<b>AUTOTUNE ERROR</b> Motor rotation detected during Autotune process (speed feedback has exceeded 20% of rated speed), or field current detected during Autotune (field current feedback has exceeded 6% of rated field current) (Alarm only operates during the Autotune sequence)	Residual motor flux when field supply is disconnected	Series fields are not recommended for regenerative drives and the series field winding should normally be left open circuit. If a series field is required, either lock the motor shaft or temporarily disconnect the series field and repeat the AUTOTUNE procedure
	Permanent magnet motor	Lock motor armature and repeat Autotuning procedure
	Separately supplied field	Disable external field supply and repeat Autotuning procedure
<b>AUTOTUNE ABORT</b> The Autotune sequence has been aborted. Coast Stop, Program Stop, Enable or Start/Run commands removed before AUTOTUNE procedure completed	Wrong AUTOTUNE sequence followed	Repeat AUTOTUNE procedure
	AUTOTUNE incomplete. (After 2 minutes the drive will time-out if still in AUTOTUNE mode)	Repeat AUTOTUNE procedure. If problem persists, contact Parker SSD Drives customer service
<b>SEQ PRE READY</b>	Coding not present.	Replace power board or chassis.
<b>CONTACTOR DELAY</b>	The internal auxiliary 3-phase contactor failed to close.	Check the position of the Calibration Scaling Switch - refer to Calibration Checks, page 7-4
<b>EXTERNAL TRIP</b> Customer alarm! Trip operates if input open or high impedance Alarm time delay : 15 seconds	Device not wired to drive or device open circuited	Check C1 to C2 connections to drive - connect C1 to C2 if customer device not fitted.
<b>REMOTE TRIP</b>	Drive not set for remote operation	Check setting of AUX I/O::REM. SEQUENCE parameter Also see AUX I/O::REM. SEQ. ENABLE parameter (Remote Trip flag set to zero.)
<b>ENABLE LOW</b>	Local Mode run with Enable input low	
<b>SEQUENCING</b>	Internal sequencing error	Contact Parker SSD Drives

Trip Message and Meaning	Possible Reason for Trip	Corrective Action
<b>COMMS TIMEOUT</b>	Remote comms timeout	See COMMS TIMEOUT parameter in the SEQUENCING function block
<b>CONFIG ENABLED</b> Configuration procedure incomplete. CONFIGURE ENABLE left in enabled state	The drive was requested to start whilst in Configuration mode.	Do not attempt to start the drive in Configuration mode
	Encoder or Microtach feedback option card incorrectly fitted to control door	Check board fully inserted in control door
	Fiber optic cable too long or cable distorted (bend radius too small for example) resulting in too weak a signal at Microtach receiver (under drive)	Reduce the tightness of the bend. The fibre optic wire should not be bent tighter than a 2" (5cm) radius
	Fiber optic cable too short resulting in too strong a signal at Microtach receiver (over drive)	Back the fibre optic cable out of the receive slightly and retighten
<b>CALIBRATION FAIL</b> Calibration fault	Signal calibration fault	If powering the unit off and on does not remove the problem, a hardware failure is suspected. Refer to Parker SSD Drives.
<b>NO OP STATION</b>	Keypad has been disconnected from drive whilst drive is running in local control.	Do not remove under these conditions
<b>AUX SUPPLY</b>	Auxilliary supply fault	Check auxilliary supply and/or mains input
<b>COMMS FAULT CODE</b>	Keypad faulty Connector faulty	Replace Keypad Replace Keypad connector
0xF100 ERROR CAM FULL INIT 0xFF02 UNIMPLEMENTED OPCODE 0xFF03 ERROR NMI 0xFF04 ERROR TRAP 0xFF05 ERROR PCB VERSION 0xFF06 ERROR PRODUCT CODE 0xFF07 ERROR HSO FULL	Critical error	These are internal software errors. If these should occur please contact PARKER SSD Drives Technical Support.

**Table 7-2 Trip Messages**



### Self Test Alarms

Self Test Alarm and Meaning	Possible Reason for Alarm
(EEPROM) CHECKSUM FAIL Parameters not saved, or are corrupted.	(The alarm appears at power-up or at the end of "Upload" UDP Transfer) Corrupted UDP file loaded - press the <b>E</b> key and perform a PARAMETER SAVE. The Drive will be returned to its factory default values.
LANGUAGE CHECKSUM FAIL Incorrect language selected, or corrupted	(The alarm appears at power-up or at the end of "Upload" UDP Transfer) Corrupted UDP file loaded - press the <b>E</b> key and reload the correct language or de-select the second language.

### Setting Trip Conditions

The following parameters in the CALIBRATION and ALARMS menus are used to set trip conditions:

CALIBRATION :: OVER SPEED LEVEL  
 ALARMS :: SPDFBK ALM LEVEL  
 ALARMS :: STALL THRESHOLD  
 ALARMS :: STALL TRIP DELAY  
 ALARMS :: REMOTE TRIP DELAY

### Viewing Trip Conditions

The following parameters in the ALARMS menu can be viewed to investigate trip conditions:

LAST ALARM  
 HEALTH WORD  
 HEALTH STORE  
 THERMISTOR STATE  
 SPEED FBK STATE  
 STALL TRIP  
 REMOTE TRIP

There are ten parameters in the ALARMS HISTORY function block that store the most recent alarm events.

## Inhibiting Alarms

The following alarms can be inhibited in the ALARMS menu.

- SPEED FBK ALARM
- ENCODER ALARM
- FIELD FAIL
- 5703 RCV ERROR
- STALL TRIP
- TRIP RESET
- REM TRIP INHIBIT

The block diagram can be wired to reset a trip condition by using the TRIP RESET parameter in the ALARMS function block. A FALSE to TRUE transition of this parameter will cause the trip to reset.

**NOTE** The STALL TRIP parameter in the DIAGNOSTICS menu is set regardless of the state of STALL TRIP inhibit. The flag is set after the stall time-out expires. The relevant bit (bit 12) in the HEALTH WORD and HEALTH STORE parameters is only set when STALL TRIP is enabled.

## Hardware Troubleshooting

This section contains troubleshooting information and flowcharts for identifying and correcting hardware problems.

**NOTE** Repair of DC590+ DRV is limited to basic part replacement only. Troubleshooting and electronic component at the board level is NOT recommended. Only the control and power boards, the control fuse F1 and SCR packs are replaceable. Refer to Chapter 8 “Routine Maintenance and Repair” for instructions.

---

### Caution

Completely isolate power before making any wiring changes, replacing fuses, or making any link/jumper changes.

---

## Control Power Missing

The DC590+ DRV, frames 3, 4, 5 and 7, derives its power from an internal power supply circuit requiring a 110VAC supply with a frequency range of 40 to 70Hz. This power is normally supplied off one phase of the main drive supply through a DRV mounted control transformer. The supply to the control transformer is limited to 230/460VAC.

The flowchart below shows the troubleshooting procedure for correcting a missing or low control power supply. The control power is missing when the drive's LCD display and its LEDs are all out.

## 7-24 Trips and Fault Finding

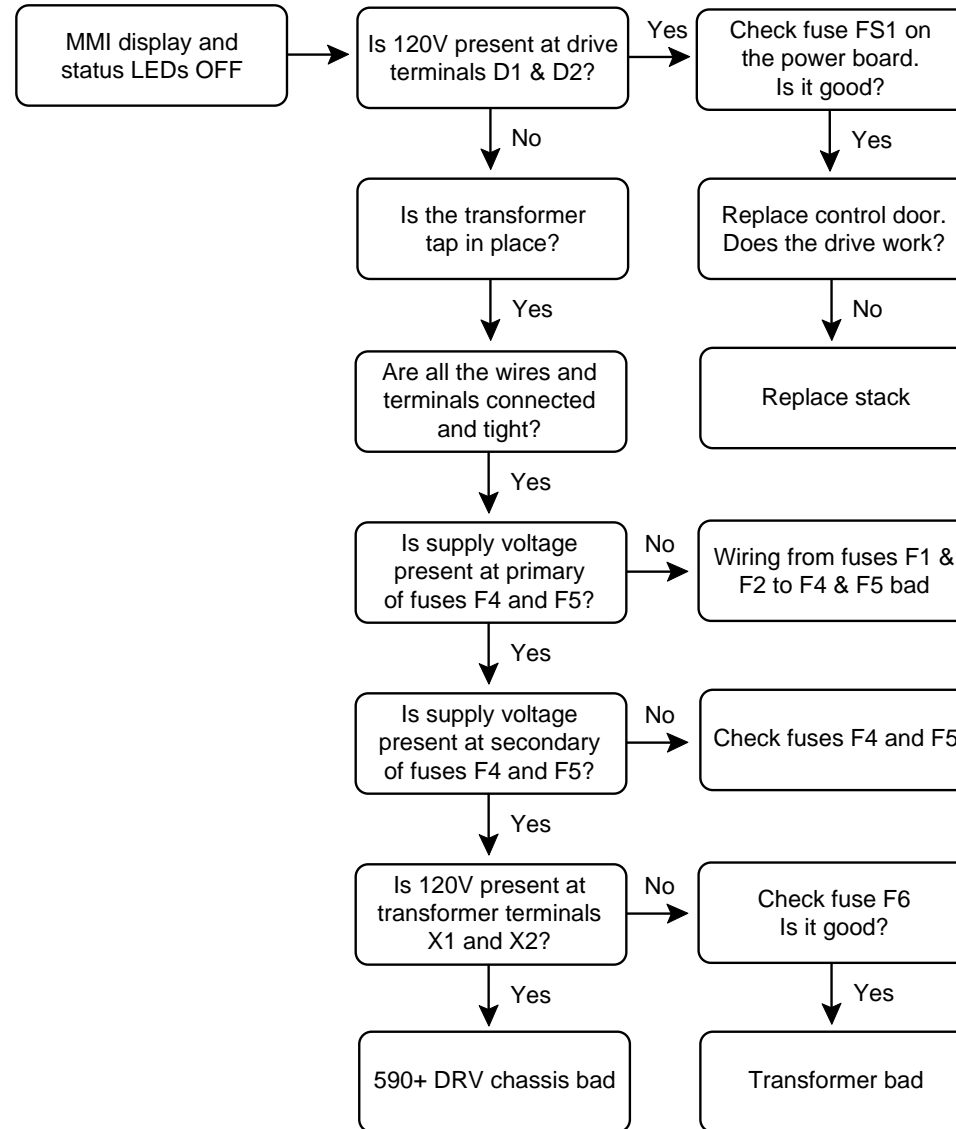


Figure 7-2 Control Power Troubleshooting Flowchart (Frames 3, 4, 5 & 7)

# Field Fail Procedure

If the motor field supply fails while the drive is running a motor, the drive should trip on either an OVERSPEED alarm or a FIELD FAILED alarm.

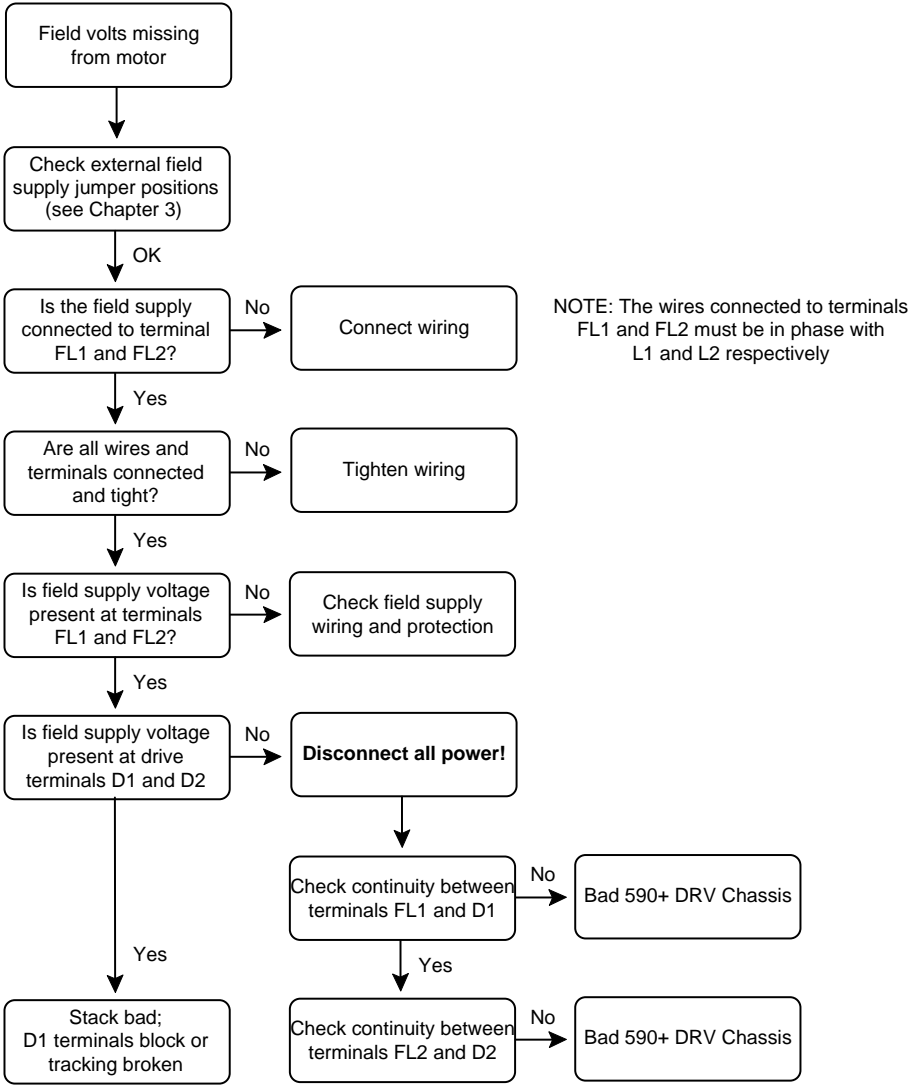


Figure 7-3 Field Power Troubleshooting Flowchart

## Contactor Failed Procedure

This flowchart is used for troubleshooting problems associated with the main contactor, AM, including wiring. Refer to the schematic/wiring diagrams in Chapter 3 when troubleshooting.

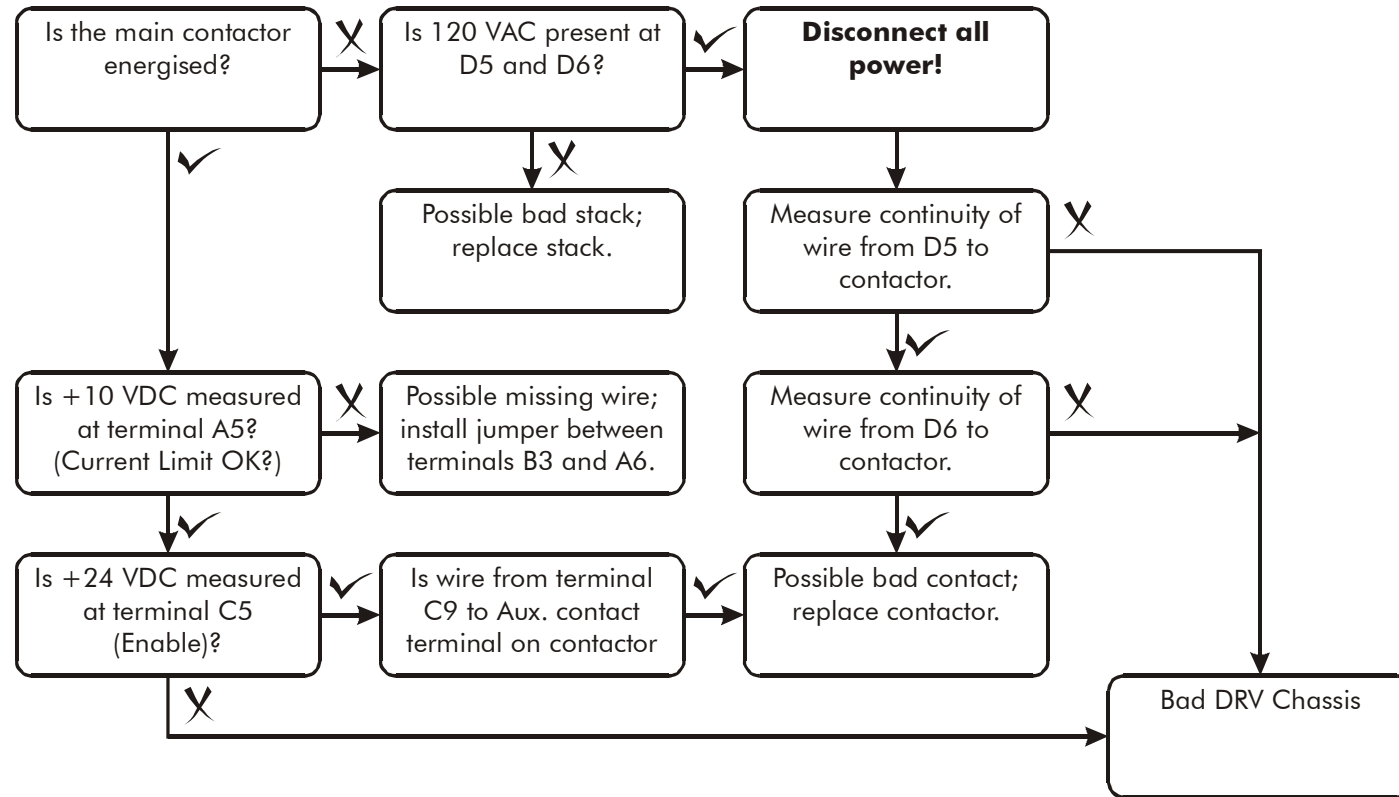


Figure 7-4 Troubleshooting Flowchart for Faulty DC Contactor

# SCR Troubleshooting

Non-regenerative drives contain three SCR packs, A, B and C. Each SCR pack contains two thyristors. Three additional SCR packs (D, E and F) mount above SCR packs A, B and C for regenerative drives. The layout of the SCR packs is shown in Figure 6-5 as they appear on the drive heatsink, from left to right.

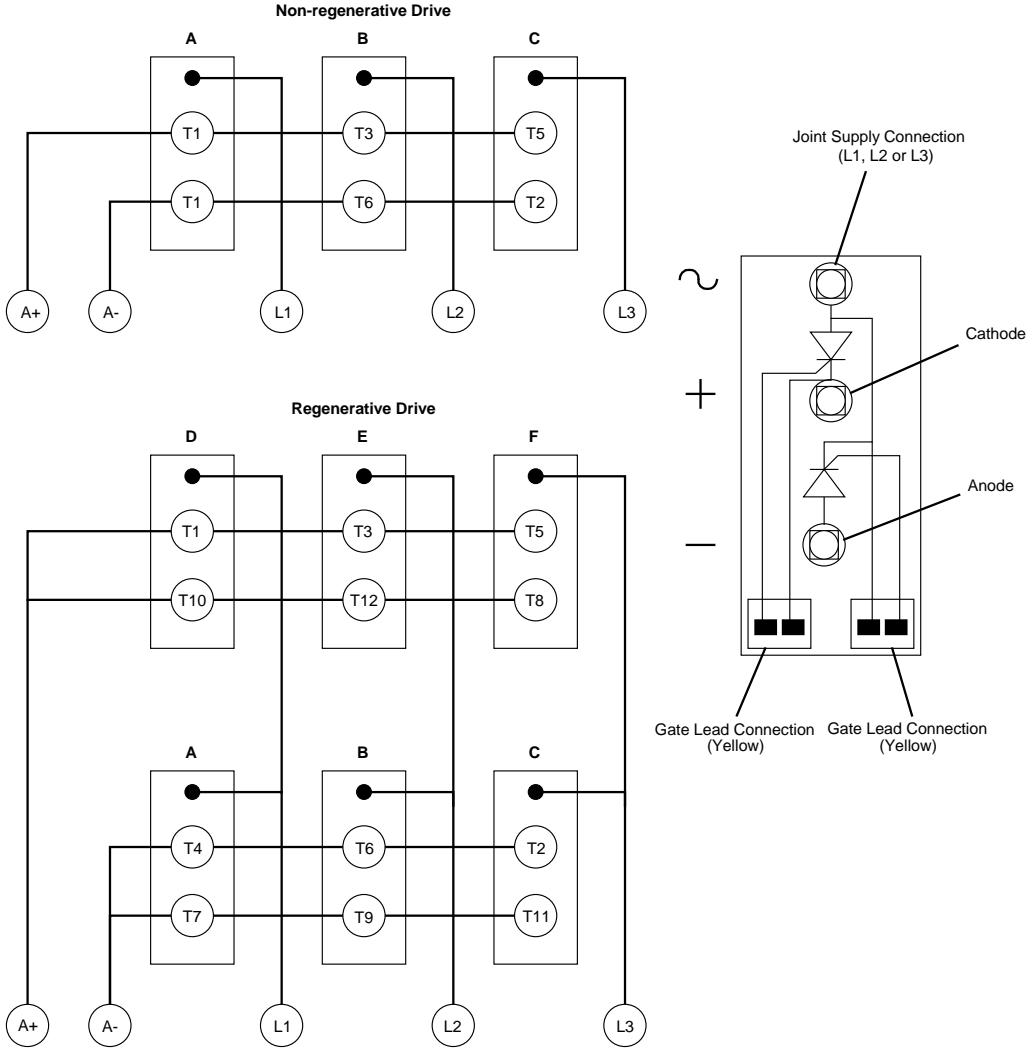


Figure 6-5 SCR Layout

## 7-28 Trips and Fault Finding

Use the tables below to determine which SCR pack is bad. The tables show the SCR being tested and the SCR pack that contains it. Measure the resistance between each armature and supply terminal. A good SCR will measure greater than  $1M\Omega$  when read from the armature to the supply terminal. Reverse the leads and repeat these measurements between the supply and armature terminals. Bad (shorted) SCRs should measure 0 to  $1k\Omega$ .

**Remove the power supply board and measure the resistance between the gate and the cathode.** It should measure between 18 and  $40\Omega$  if good. A schematic of the SCR pack is shown above. The outer most terminals connected to yellow leads at the bottom of each SCR pack are the thyristor gate terminations.

Non-regenerative Drives			
Terminal	L1	L2	L3
A+	T1 (A)	T3 (B)	T5 (C)
A-	T4 (A)	T6 (B)	T2 (C)

Regenerative Drives			
Terminal	L1	L2	L3
A+	T1/T10 (D)	T3/T12 (E)	T5/T8 (F)
A-	T4/T7 (A)	T6/T9 (B)	T2/T11 (C)

### Motor Checks

Several alarm messages are caused by problems with the motor. Most motor problems relate to insulation breakdown, overtemperature and armature brush and commutation problems. Check the motor armature and field with a megger to ensure that the motor winding insulation has not degraded and shorted one conductor to another or to ground. Continuity checks require an ohmmeter for determining whether motor windings or leads have opened or shorted. Continuity measurements should be least the  $1\Omega$ . Insulation measurements should be greater than  $10M\Omega$ .

***Armature resistance for motors less than 10Hp (7.5kW) can measure up to  $3\Omega$ .***

---

### Caution

Disconnect the motor leads from the drive before using a megger to check for motor ground faults.

---

Also check the motor commutator for flashover. Clean the commutator and motor brushes if worn or dirty. If the motor is fitted with a blower, change or clean the blower filter regularly.

## Common Performance Problems

### Parameter Toggles Between Two Conditions

This problem occurs when two parameters write to a third parameter. The two parameters overwrite each other and fight for control of the problem parameter.

### No Speed Demand

If all the analog signals are connected to the proper terminals and have the correct sign, I DMD. ISOLATE may be set incorrectly. Monitor terminal C8; if it is OFF, at 0VDC, terminal C8 may have been tagged for a non-standard function. Monitor parameter SETUP PARAMETERS::CURRENT LOOP::I DMD. ISOLATE. It should be DISABLED for speed control. If it ENABLED, only a signal at terminal A3, ANIN 2, will create a current demand needed to turn the motor.

### Speed Setpoint has Unwanted Offset

Terminal A8, Total Speed Setpoint, is compiled from SETPOINTS 1 through 4. Monitor each setpoint individually in SETUP PARAMETERS::SPEED LOOP::SETPOINTS. If one is incorrect, i.e. has been left at an undesired value, simply reset it to zero.

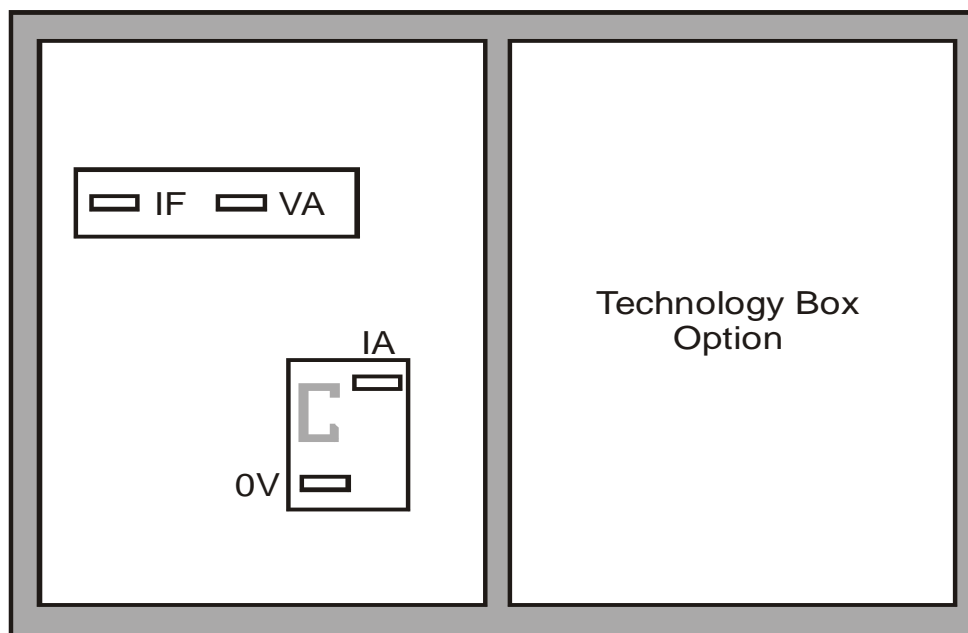
### Signal does not get through Ramp

When parameter RAMP HOLD is ON, the ramp output is held to its last input value. Set RAMP HOLD to OFF to allow the signal change.



## Test Points

The following test points are located on the control board and can be accessed through the Technology Option housing. When used with a meter, they will provide valuable information in the event of a fault. Refer to Parker SSD Drives for further information.



Test Points viewed through the front of the drive.

Test Point	Description
IF	Field current feedback 0.0V = 0% 4.0V = 100% (mean voltage), value of <i>FIELD I FBK</i> diagnostic, Tag No. 300
IA	Armature current feedback $\pm 1.1V \equiv \pm 100\%$ (mean current), value of <i>CURRENT FEEDBACK</i> diagnostic, Tag No. 298
VA	Armature volts feedback +5V $\equiv$ +100%, +2.5V $\equiv$ 0%, 0V $\equiv$ -100% calculated VA (mean voltage), value of <i>TERMINAL VOLTS</i> diagnostic, Tag No. 57
0V	Control board 0V reference

# Chapter 8 **Routine Maintenance and Repair**

This chapter contains preventive maintenance procedures, contact details for repairing the unit, and instructions for replacing fuses and fans.

## Maintenance

Service Procedures

Preventive Maintenance

## Repair

- Saving Your Application Data
- Returning the Unit to Parker SSD Drives
- Disposal
- Technical Support Checks
- Repairs for Frames 4 & 5

Replacing the Fan (Frames 4 & 5)

- Repairs for Frame 6

AC Fuse Replacement (Frame 6 Non-Regen Unit - 2Q)

DC Fuse Replacement (Frame 6 Regen Unit - 4Q)

Replacing a Phase Assembly (Frame 6)

Replacing a Fan (Frame 6)

- Repairs for Frame 7

Fuse Replacement (Frame 7)

- Phase Assembly Replacement (Frame 7)



# Maintenance

Because of its solid state design, the DC590+ DRV Digital drive has few items requiring service or maintenance. Service is typically a matter of replacing fuses, checking electrical contacts, and isolating problems in the overall system application.

---

## Caution

Service procedures must be performed by qualified personnel with an understanding of the dangers inherent in high voltage applications and the precautions necessary when servicing industrial equipment. The customer is responsible for assessing the technical competency of in-house service personnel.

---

## Service Procedures

### Required Tools and Equipment

Tools needed for routine service operations include basic hand tools — screwdrivers, wrenches, etc.

### WARNING

**Only qualified service personnel should attempt to repair or replace parts in the drive.**

**Isolate the entire drive from electrical power before attempting to work on it.**

## Preventive Maintenance

You should perform regular preventive maintenance every six months to ensure long life and continued usefulness of the 590. Keep the drive and its components clean, check auxiliary fans if fitted, and make sure connections and mounting bolts have not loosened from vibration.

The control and field wires can be checked by gently attempting pulling the wires out of the terminals. The terminals should hold the wires firmly in place.

All the remaining wires should be checked with a torque wrench. Refer to Appendix E: "Technical Specifications" - Termination Tightening Torque tables.

## Repair

There are no user-serviceable components.

**IMPORTANT** MAKE NO ATTEMPT TO REPAIR THE UNIT - RETURN IT TO PARKER SSD DRIVES.

### Saving Your Application Data

The Drive retains saved settings during power-down. You can download and upload this back into the repaired unit, if necessary. You may, depending upon your knowledge of the fault, attempt the back-up of your application data now, refer to Chapter 6: “The Keypad” - Copying an Application.

If the fault clearly lies within the MMI, then return the unit for repair.

### Returning the Unit to Parker SSD Drives

Before calling Parker SSD Drives Customer Service, make sure you have the following information available:

Information	Source
Model number and serial number	590 Digital drive rating label
Motor horsepower, armature current and voltage, field current and voltage, base and top speed ratings	Motor nameplate
Speed voltage feedback per 1000 RPM (analog device), or counts per revolution(digital device)	Speed feedback device nameplate
Applications information and operating environment	System drawings

Contact your nearest Parker SSD Drives Service Centre to arrange return of the item.

You will be given a *Returned Material Authorisation*. Use this as a reference on all paperwork you return with the faulty item.

Pack and despatch the item in the original packing materials; or at least an anti-static enclosure. Do not allow packaging chips to enter the unit.

### Warranty Information

Refer to Parker Hannifin Manufacturing Limited Terms and Conditions of Sale. These documents are available on request at [www.parker.com](http://www.parker.com).

## Disposal

This product contains materials which are consignable waste under the Special Waste Regulations 1996 which complies with the EC Hazardous Waste Directive - Directive 91/689/EEC.

We recommend you dispose of the appropriate materials in accordance with the valid environmental control laws. The following table shows which materials can be recycled and which have to be disposed of in a special way.

Material	Recycle	Disposal
metal	yes	no
plastics material	yes	no
printed circuit board	no	yes

The printed circuit board should be disposed of in one of two ways:

1. High temperature incineration (minimum temperature 1200°C) by an incinerator authorised under parts A or B of the Environmental Protection Act
2. Disposal in an engineered land fill site that is licensed to take aluminium electrolytic capacitors. Do not dispose of in a land fill site set aside for domestic waste.

## Packaging

During transport our products are protected by suitable packaging. This is entirely environmentally compatible and should be taken for central disposal as secondary raw material.

## Technical Support Checks

The results of the following checks will be very useful to Parker SSD Drives' Technical Support.

### Caution

Please only attempt these checks if you are electrically competent.

Miscellaneous Checks	<input type="checkbox"/> or <input type="checkbox"/>
Check 24V present at Terminals C1 to C9 (C1 is 0V) - dc	
Check ±10V present at Terminals B3 and B4 (B1 is 0V) - dc	
Check auxiliary supply present at Neutral & Line, 110/240V ac	
Check the fans rotate, where applicable	

**WARNING**  
**Now isolate the unit completely from all supplies. It may be necessary to remove an armature and field connection to carry out the following checks.**

<b>Continuity Test on Fuses Using a Meter</b>	✓ or ✗
Check the coding fuses on the power board Check the auxiliary fuses etc. (fan fuse, if applicable)	
<b>Diode Check on Power Terminals Using a Meter</b>	✓ or ✗
A+ to L1, L2, L3 and Earth Terminal = Open Circuit A- to L1, L2, L3 and Earth Terminal = Open Circuit	
<b>Internal Field Check Using a Meter</b>	✓ or ✗
All the coding fuses must be OK before continuing with the following checks since the fuses are in the circuit.	
-ve to L1 & +ve to F+ = Diode Drop (approximately 0.5V) -ve to L2 & +ve to F+ = Diode Drop (approximately 0.5V) -ve to F- & +ve to F+ = Diode Drop (approximately 0.5V) -ve to L1 & +ve to F- = Open Circuit -ve to L2 & +ve to F- = Open Circuit	
<b>External Field Check Using a Meter</b>	✓ or ✗
-ve to FL1 & +ve to F+ = Diode Drop (approximately 0.5V) -ve to FL2 & +ve to F+ = Diode Drop (approximately 0.5V) -ve to F- & +ve to F+ = Diode Drop (approximately 0.5V) -ve to FL1 & +ve to F- = Open Circuit -ve to FL2 & +ve to F- = Open Circuit	

Make a note of the Serial Number and Model Number.

<b>Serial Number</b>		<b>Model Number</b>	
----------------------	--	---------------------	--

**Re-establish all connections. All terminals should be secure and not over-torqued.**

## Repairs for Frames 4 & 5

### Replacing the Fan (Frames 4 & 5)

#### WARNING!

Ensure that all wiring is electrically isolated and cannot be made “live” unintentionally by other personnel.

Remove the terminal cover. Unscrew the three screws securing the baffle and remove. Disconnect the fan supply cable. Remove the two M8 earth/ground screws on the back of the drive (Frame 5). Remove the fan cover. Remove the fan assembly and screws as detailed above.

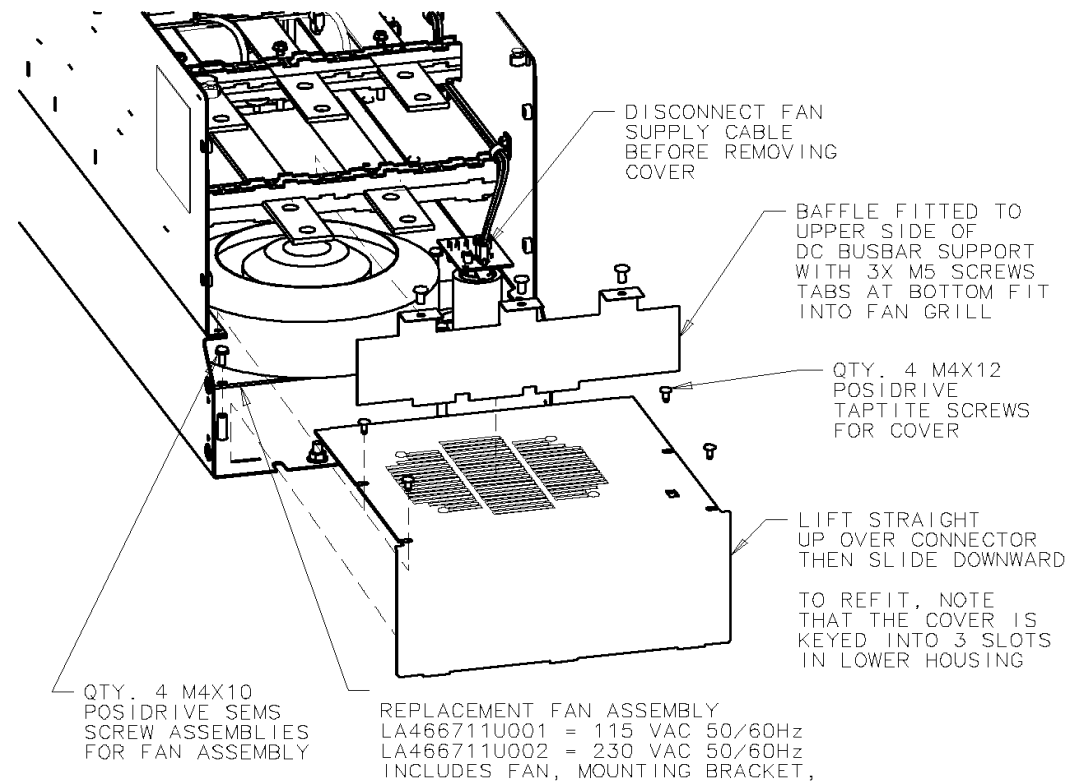
Reverse the procedure for refitting the fan assembly – refer to the refitting note in the diagram above. The replacement fan assembly includes the fan, cover and capacitor, requiring just a simple connection of the supply cable.

### Heatsink Cooling Fan Connections

These fans are connected on the power board to the cooling fan supplies, CONN 2 or 3 as described below:

- 380, 500, 725, 830A models have a single fan matched to the auxiliary supply and connected to CONN 2.

1580A models have two fans matched to the auxiliary supply connected to CONN 2 & 3.





## Repairs for Frame 6

### WARNING!

The phase assembly metalwork (L1, L2 & L3) is LIVE when the unit is switched on. Isolate the entire DC590+ DRV drive from electrical power before attempting to work on it.

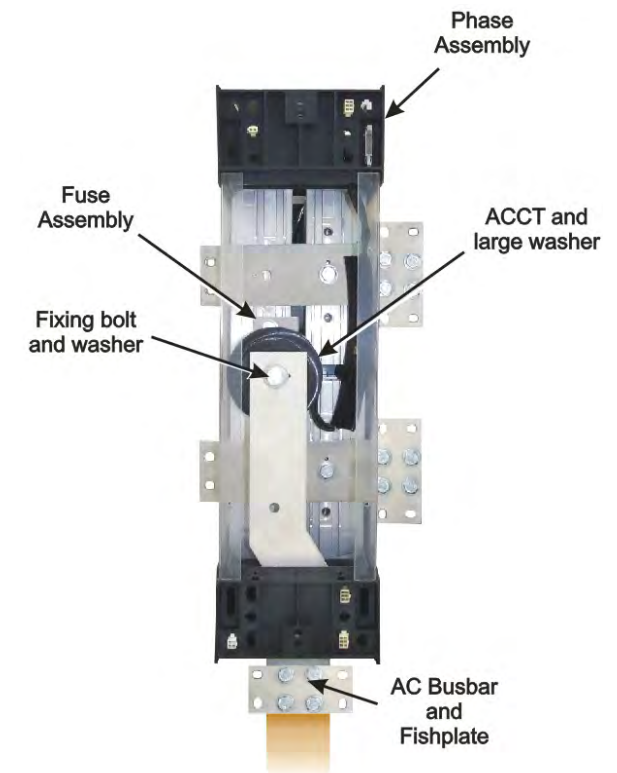
Only qualified service personnel should attempt to repair or replace parts in the 590+.

## AC Fuse Replacement (Frame 6 Non-Regen Unit - 2Q)

The AC fuse can be replaced *in-situ*. With the front of the drive removed (the Control Panel Assembly), the replacement should take about 20 minutes. Removing the Control Panel Assembly from the cubicle completely will make access easier, but requires the removal of all connections made to it. It may be possible to support the Control Panel Assembly (11.25kg/25 lbs) and sling it away from the Phase Assemblies far enough to gain access.

### Removal

1. Loosen the retaining screws in the Field Controller plug. Unplug all connections to the Door Assembly (control connections) and the Field Controller (Auxiliary Plug and Field Plug).
2. Undo the fixings to remove the front cover from the Control Panel Assembly.
3. Disconnect the flying leads of the Control Panel Assembly from the three Phase Assemblies. Remove the external earth connection(s) made to the Front Cover.
4. Remove the 12mm x M6 fixings in the four corners that secure the Control Panel Assembly. Loosen the top and bottom central support screws (but do not remove) and lift the Control Panel Assembly away from the three Phase Assemblies.
5. Remove the fixings that secure the failed Phase Assembly front cover.
6. Disconnect the fishplate connected to the AC Busbar.
7. Slowly remove the ACCT's fixing bolt and washer from the AC Busbar, supporting the ACCT and large (rubber) washer as you do so. Lower the ACCT to one side and remove the rubber washer.
8. The fuse is mounted on a plate. Remove this Fuse Assembly from the Phase Assembly.
9. On the bench, undo the central bolt from the Fuse Assembly taking note of the placement of washers and other parts.



## Refitting

1. Refit the Fuse to the mounting plate. Torque to 45Nm (33 ft.lbf). Fix the mounting plate to the Phase Assembly, securing it with the two bolts and washers. Torque to 32Nm (23.6 ft.lbf).
2. Slide the AC Busbar into position in the Phase Assembly and secure the ACCT and large rubber washer with the central bolt and washer. Torque to 45Nm (33 ft.lbf).
3. Reconnect the AC Busbar's fishplate carrying the mains connection (L1, L2 or L3). Torque to 55Nm (40.6 ft.lbf).
4. Refit the Phase Assembly front panel and secure with four screws and washers.
5. Offer up the Control Panel Assembly to the three Phase Assemblies and hang on the central support screws. Secure with 12mm x M6 screws and washers.
6. Reconnect the flying leads of the Control Panel Assembly to the three Phase Assembly units. Tighten the retaining screws in the Field Controller plug. Refer to Chapter 3: "Installing the Drive" - Frame 6: Assembly and Installation - Terminals.
7. Refit the front cover to the Control Panel Assembly, securing with the screws and washers. Connect the external earth to the Front Panel.

## DC Fuse Replacement (Frame 6 Regen Unit - 4Q)

The DC fuse(s) can be replaced *in-situ*. With the front of the drive removed (the Control Panel Assembly), the replacement should take about 20 minutes. Removing the Control Panel Assembly from the cubicle completely will make access easier, but requires the removal of all connections made to it. It may be possible to support the Control Panel Assembly (11.25kg/25 lbs) and sling it away from the Phase Assemblies far enough to gain access.

## Removal

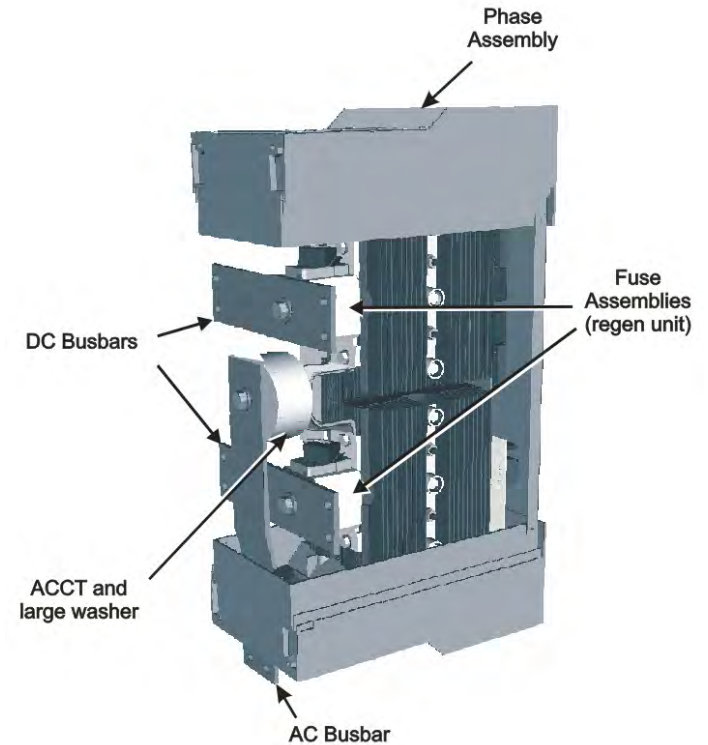
1. Loosen the retaining screws in the Field Controller plug. Unplug all connections to the Door Assembly (control connections) and the Field Controller (Auxiliary Plug and Field Plug).
2. Undo the fixings to remove the front cover from the Control Panel Assembly.
3. Disconnect the flying leads of the Control Panel Assembly from the three Phase Assemblies. Remove the external earth connection(s) made to the Front Cover.
4. Remove the 12mm x M6 fixings in the four corners that secure the Control Panel Assembly. Loosen the top and bottom central support screws (but do not remove) and lift the Control Panel Assembly away from the three Phase Assemblies.
5. Remove the four screws that secure the failed Phase assembly front panel. Remove the front panel.

## 8-8 Routine Maintenance and Repair

6. Remove the bolts securing the fishplates to the DC Busbar nearest the failed fuse.
7. If the failed fuse is located underneath the AC busbar: slowly remove the ACCT's fixing bolt and washer from the AC Busbar, supporting the ACCT and large (rubber) washer as you do so. Remove the rubber washer and lower the ACCT to one side.
8. Unplug the lead connected to the microswitch that is fitted to the side of the Fuse Assembly.
9. The fuse is mounted on a plate. Remove the two bolts and washers that secure this plate to the Phase Assembly and lift away the Fuse Assembly and DC Busbar.
10. On the bench, undo the central bolt from the Fuse Assembly taking note of the placement of washers and other parts. Re-build the assembly with the new fuse. Tighten the DC Busbar bolt to 45Nm (33 ft.lbf).

### Refitting

1. Refit the Fuse to the Mounting Plate. Torque to 45Nm (33 ft.lbf). Fix the mounting plate to the Phase Assembly, securing it with the two bolts and washers. Torque to 32Nm (23.6 ft.lbf).
2. Plug the lead back onto the microswitch (removed earlier).
3. Slide the AC busbar into in the Phase Assembly and secure with the bolt and washer. Torque to 45Nm (33 ft.lbf).
4. Refit the fishplates that connect to the DC Busbars. Torque to 55Nm (40.6 ft.lbf).
5. Offer up the Control Panel Assembly to the three Phase Assemblies and hang on the central support screws. Secure with 12mm x M6 screws and washers.
6. Reconnect the flying leads of the Control Panel Assembly to the three Phase Assembly units. Tighten the retaining screws in the Field Controller plug. Refer to Chapter 3: "Installing the Drive" - Frame 6: Assembly and Installation - Terminals.
7. Refit the front cover to the Control Panel Assembly, securing with the screws and washers. Connect the external earth to the Front Panel.



## Replacing a Phase Assembly (Frame 6)

### NOTE

The Non-Regen Phase Assembly (2Q) weighs 28kg (62 lbs)

The Regen Phase Assembly (4Q) weighs 33kg (73 lbs)

With the front of the drive removed (the Control Panel Assembly), the replacement should take about 20 minutes. Removing the Control Panel Assembly from the cubicle completely will make access easier, but requires the removal of all connections made to it. It may be possible to support the Control Panel Assembly (11.25kg/25 lbs) and sling it away from the Phase Units far enough to gain access.

### Removal

1. Remove the plugs for the control wiring, auxiliary supply and field connections (loosen the screws to remove the field plug). Remove the Protective Earth connections (PE).
2. Undo the fixings to remove the front cover from the Control Panel Assembly.
3. Disconnect the flying leads of the Control Panel Assembly from the three Phase Assemblies.
4. Remove the 12mm x M6 fixings in the four corners that secure the Control Panel Assembly. Loosen the top and bottom central support screws (but do not remove) and lift the Control Panel Assembly away from the three Phase Assemblies.
5. Remove the bolts securing the fishplates to the DC Busbars.
6. Fit an M10 x 20mm long "temporary hanging" bolt to the "temporary hanging" mounting hole (top-centre) of the phase assembly to be removed. Screw it in loosely, leaving a few millimetres of thread still showing.
7. Remove the fixing bolts that hold the failed Phase Assembly onto the back panel. Lift it off the "temporary hanging" bolt. Refer to the note about weights at the top of the page.

### Refitting

1. Hang the new Phase assembly onto the "temporary hanging" bolt. The fans should be at the bottom of the unit. Fit the 4 off M10 bolts and torque to 32Nm (23.6 ft.lbf).
2. Remove the "temporary hanging" bolt.
3. Refit the fishplates to the DC Busbars. Torque to 55Nm (40.6 ft.lbf).
4. Refit the front panel and secure with four screws and washers.
5. Offer up the Control Panel Assembly to the three Phase Assemblies and hang on the central support screws. Secure with M6 x12mm long screws and washers.
6. Reconnect the flying leads of the Control Panel Assembly to the three Phase Assembly units. Refer to Chapter 3: "Installing the Drive" - Frame 6: Assembly and Installation - Terminals.
7. Refit the front cover to the Control Panel Assembly, securing with the screws and washers.
8. Connect the plugs for the control wiring, auxiliary supply and field connections (tighten the screws to secure the field plug). Remake the Protective Earth connections (PE).

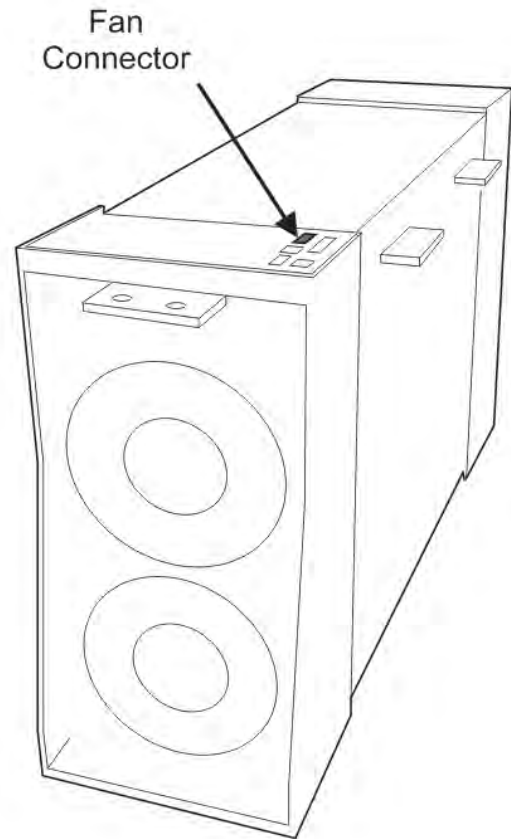


## Replacing a Fan (Frame 6)

There are two fans mounted inside the base of each Phase Assembly. These are hard-wired together and are supplied as an assembly. Replacement of both fans is easy and should take about 15 minutes.

### Removal

1. Remove the four screws that hold the bottom fan grille in place.
2. Remove the two screws from each fan.
3. Trace the route of the fan cable back to the front of the phase assembly and remove the fan connector from the phase assembly.
4. Remove the fans and cable assembly from phase assembly.
5. Fit the two fans to the phase assembly and secure with the screws. Hand-tighten.
6. Fit the new fan connector to the front of the phase assembly.



## Repairs for Frame 7

### Fuse Replacement (Frame 7)

1. Remove the front cover.
2. Unplug the ribbon cables to the trigger boards.
3. Open the swing-frame using the two quick-release fixings at the right hand end.

### 590+ 4Q Product (Regenerative)

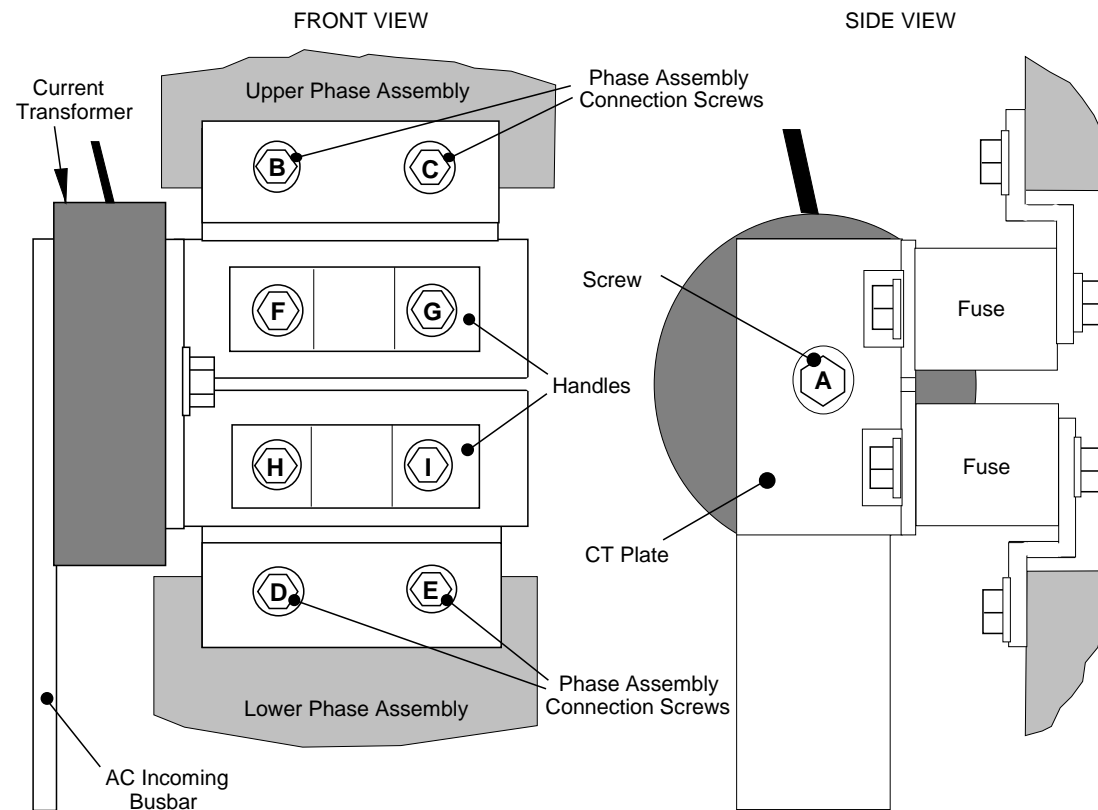


Figure 8-1 590+ (Frame 7) Fuse Replacement Diagram

**IMPORTANT** *When re-assembling the unit, apply a 'zinc-loaded' jointing compound between the fuses and busbars, and between the busbars and phase assemblies (BICC BX1 - Parker SSD Part No. EA466241)*

Observe all tightening torque levels, refer to Appendix E: "Technical Specifications" - Termination Tightening Torque (Frame 7).

### ***Bench-Top Replacement Procedure***

1. Disconnect the relevant fuse microswitch assembly by unplugging the lead assembly from the rear trunking.
2. Remove the M12 (A).
3. Loosen (but do not remove) the four M10 screws (B, C, D, E).
4. Hold the fuse assembly handle in one hand and remove the two screws (D, E) from the lower phase assembly.

**CAUTION: The fuse assembly weighs 9kg maximum.**

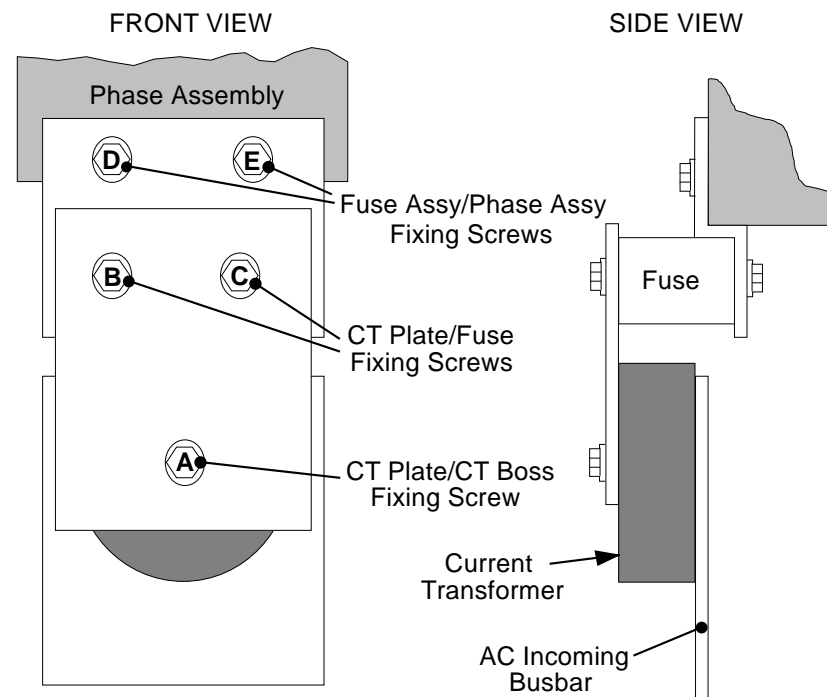
5. Hold the fuse assembly handles and remove the two screws (B, C) from the upper phase assembly.
6. With the fuse assembly on the bench, remove the M12 screws (F, G, H, I) holding the fuses to the busbars. **Take a note of the fuse microswitch position on the fuse assembly**, do not forget, as the lead assembly will not fit if mounted in the wrong position.

Reverse the above procedure for replacement. Remember to re-connect the fuse microswitches.

### ***In-Situ Replacement Procedure***

1. Disconnect the relevant fuse microswitch assembly by unplugging the lead assembly from the rear trunking.
2. Remove the M12 screw (A), and the 4 screws (F, G, H, I). Remove the CT plate and handles.
3. Remove the relevant screws (B, C or D, E) and lift the fuse busbar assembly from the phase assembly.
4. Replace the fuse on the busbar and re-connect the microswitch. Fully tighten the fuse to the busbar.
5. Fit the fuse busbar assembly on to the phase assembly. Don't fully tighten the screws yet.
6. Position the CT plate on top of the fuses. The slack in the fuse busbar assembly will allow the fixing holes to be aligned. Insert the screws.
7. Fully tighten all screws (including those in 5 above).
8. Re-connect the fuse microswitches.

## 591 + 2Q Product (Non-Regenerative)



**Figure 8-2 591+ Fuse Replacement Diagram**

**IMPORTANT** *When re-assembling the unit, apply a 'zinc-loaded' jointing compound between the fuses and busbars, and between the busbars and phase assemblies (BICC BX1 - Parker SSD Part No. EA466241)*

Observe all tightening torque levels, refer to Appendix E: "Technical Specifications" - Termination Tightening Torque (Frame 7).

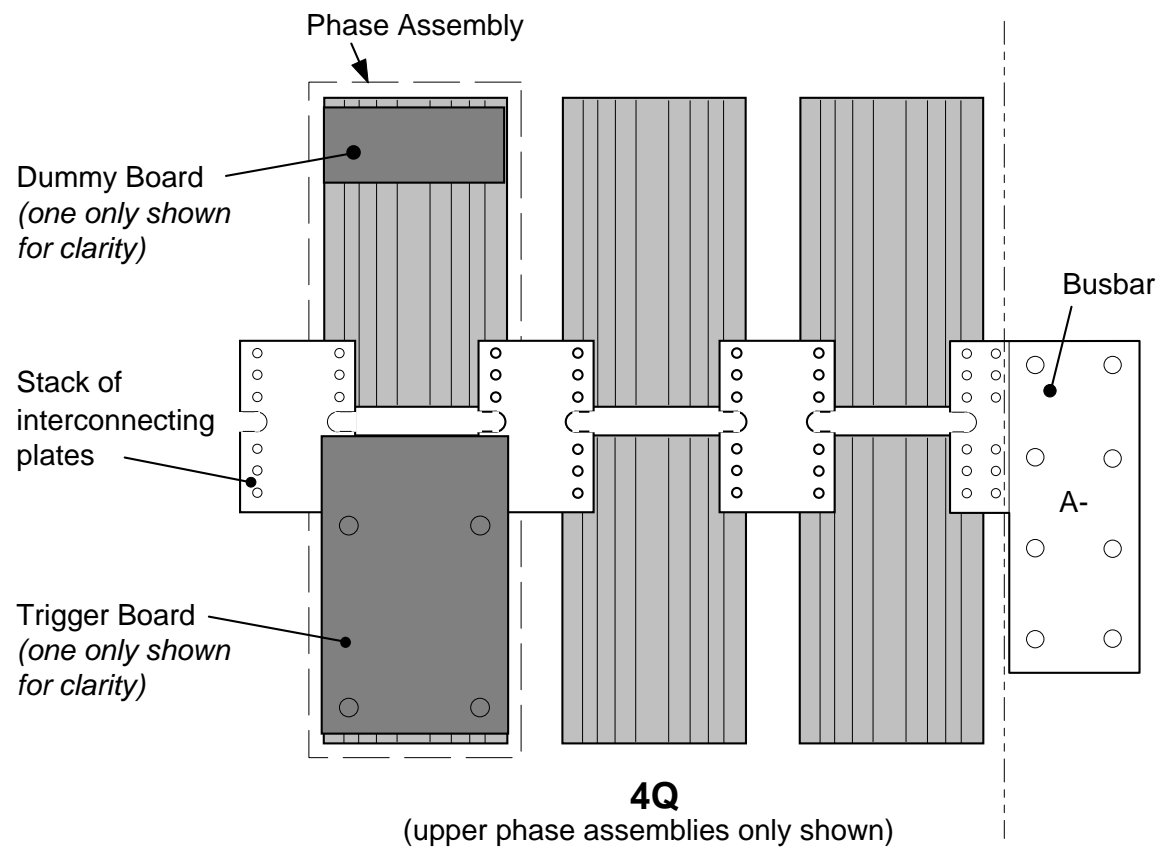
### ***Bench-Top Replacement Procedure***

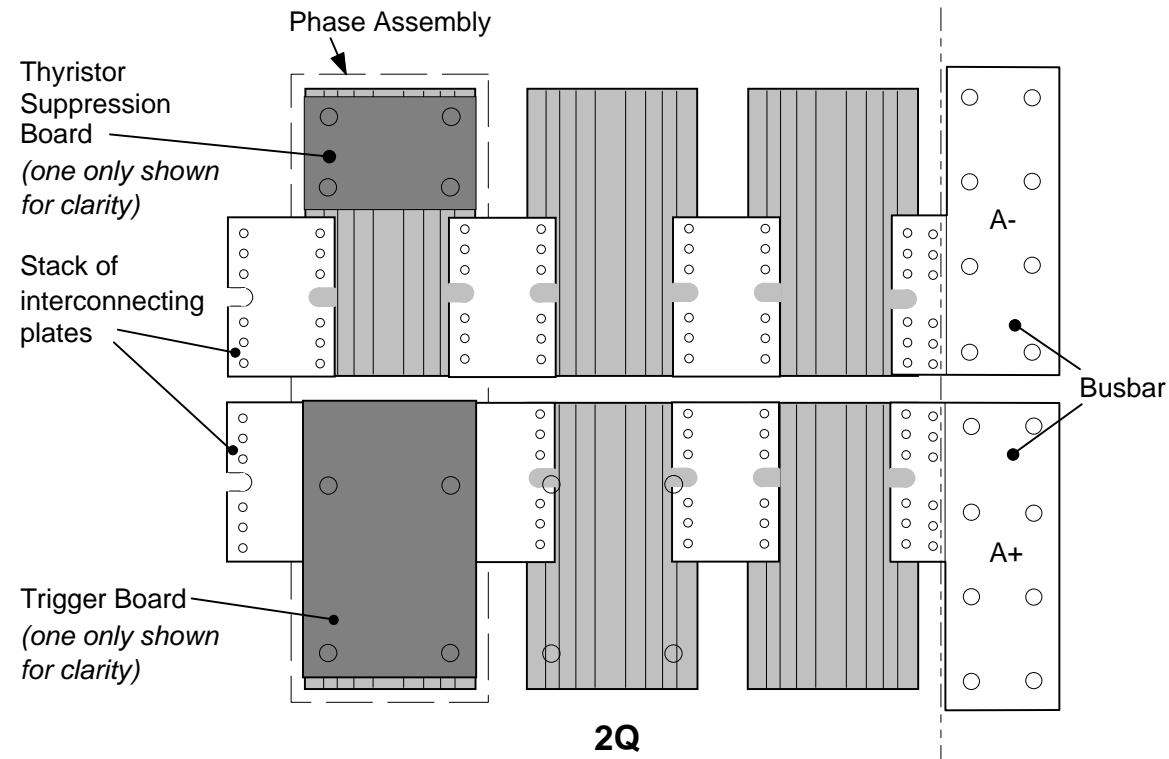
Working on the relevant fuse assemblies:

1. Remove the M12 screw (A).
2. Release the two M12 screws (B, C) and remove the CT plate.
3. Remove the two M10 screws (D, E) fixing the fuse assembly to the phase assembly.
4. On the bench, replace the relevant fuse on the fuse assembly.
5. Reverse the procedure for re-fitting.



## Phase Assembly Replacement (Frame 7)





**Figure 8-3 Front View of Phase Assemblies**

**IMPORTANT** When re-assembling the unit, apply a 'zinc-loaded' jointing compound between the fuses and busbars, between the busbars and phase assemblies and between the interconnection plates and the heatsink (BICC BX1 - Parker SSD Part No. EA466241)

Observe all tightening torque levels, refer to Appendix E: "Technical Specifications" - Termination Tightening Torque (Frame 7).

### ***Phase Assembly Removal Procedure***

1. Referring to Figure 8-1 (590+) or Figure 8-2 (591+), remove the M12 screw (A). Undo the four screws (B, C, D, E) which allows the CT plate and fuse assembly to be removed.
2. Unplug the thyristor gate leads and the heatsink overtemperature leads from the relevant phase assembly trigger board. Remove the same leads from the adjacent phase assembly or assemblies (this is necessary to gain complete access to the interconnecting plates.) If you are removing the phase assembly from a 591+ (2Q) product, also disconnect the thyristor suppression lead from the trigger boards.

## 8-16 Routine Maintenance and Repair

3. Remove the trigger board by releasing the four M6 Sems nuts fixing the PCB to the assembly. If you are working on a 590+ (4Q), remove the dummy trigger board, or if working on a 591+ (2Q) remove the thyristor suppression board. Remove the air duct from the top of the phase assembly to gain access to the DC interconnection plates.  
Do not remove the trigger board support spacers.
4. Remove the DC interconnection plates between the phase assembly and its adjacent assemblies, either output terminals or phase assemblies.
5. If changing an upper phase assembly on a 590+ or 591+ remove the top baffle. This is achieved by pushing out the two end flaps of the plenum chamber and unclipping the top baffle from the top cover baffle stops and the top of the phase assemblies. Remove the vertical baffles between phase assemblies.
6. If changing a lower phase assembly on a 590+, remove the lower air duct.
7. Remove the complete phase assembly by removing the four M6 Sems nuts at the top and bottom of the phase assembly.

**NOTE** On the 591+ 2Q, the left hand screw retains the phase coding connection which should be pushed to one side before lifting the phase assembly.

### *Phase Assembly Fitting Procedure*

1. Position the repaired or spare phase assembly on to the back panel spacer. (Remember to re-connect the coding lead to the bottom of the phase assembly when working on a 591+ 2Q).

Check for correct orientation of the assembly. Fix in position with 4 x M6 Sems nuts and tighten to the correct torque level.

Refit the interconnecting plate stacks between the phase assemblies. A stack of three plates are used on a 1200 Amp unit, four on a 1700 Amp unit, five on a 2200 Amp unit and six on a 2700 Amp unit. On a 4Q unit the plates interconnect both the upper and lower thyristors and adjacent phase assemblies. On the 2Q unit the plates interconnect adjacent phase assemblies. Tighten to the correct torque level.

**NOTE** a) **When fitting a spare phase assembly there may be some misalignment to the new phase where the interconnection plates do not fit easily. In this case, loosen the trigger support spacers which will allow adjustment of the support bars. Fit the interconnecting plates and re-tighten all units, including spacers.**

*b) When re-assembling the interconnection plates it is important that a good electrical contact is made between the plates and the aluminium heatsink. Apply a layer of 'zinc-loaded' jointing compound between the interconnection plates and the heatsink.*

2. Refit the air duct on the phase assembly ensuring that the duct fits inside the side ducting of the phase assembly.
3. Refit the trigger board (thyristor suppression board or dummy board as appropriate) and secure with the M6 Sems nuts.
4. Reconnect the gate leads, thermostat and suppression lead as necessary. The gate leads cannot be fitted incorrectly as they are polarised by the plugs.
5. Re-fit the top baffle (either plenum cover or lower 4Q air duct) and vertical baffles.
6. Replace the fuse.
7. Re-close the swing-frame.

Replace the trigger board connectors.

# Appendix A **Serial Communications**

## System Port (P3)

- UDP Support
- System Port (P3) Set-up

UDP Transfer Procedure

MMI Dump Procedure

- DSELite Support

System Port (P3) Set-up

- 5703 Support

System Port (P3) Set-up

- EI Bisynch ASCII Support

System Port (P3) Set-up

- EI Binary Support

System Port (P3) Set-up

EI Bisynch Binary Message Protocol

EI Bisynch Binary Parameter Specification Tables

- Error Codes

ERROR REPORT (EE)



# System Port (P3)

This port has several uses:

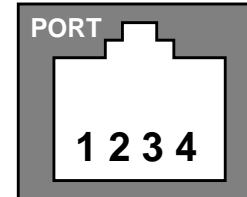
<b>UDP Support</b>	Upload information from a PC	Refer to page A-2
<b>DSELite</b>	Parameters can be monitored and updated by DSELite (or other suitable PC programming tool)	Refer to page A-5
<b>5703 Support</b>	Connection for a Parker SSD Dries' 5703 Setpoint Repeater Unit	Refer to page A-6
<b>EI ASCII</b>	Communications with other control/supervisory equipment	Refer to page A-9
<b>EI BINARY</b>	Communications with other control/supervisory equipment	Refer to page A-14

## Drive Connections

The port is an un-isolated RS232, 9600 Baud (default), supporting the standard EI BISYNCH ASCII communications protocol. Contact Parker SSD Drives for further information.

Use a standard P3 lead to connect to the Drive.

P3 Port Pin	Lead	Signal
1	Black	0V
2	Red	24V
3	Green	TX
4	Yellow	RX



### 6-Way Lead to DB9/DB25 Connector

**IMPORTANT** There is 24V present on pin 2 of the P3 port. This may damage your PC or the Drive.

P3 Port Pin	Lead	Female DB9 Pin	Female DB25 Pin
1	Black	5	7
2	Red	not connected	not connected
3	Green	2	3
4	Yellow	3	2

## UDP Support

The Upload Download Protocol (UDP) can be used to transfer text files between the drive and a host computer using the P3 port. Files that can be transferred using UDP are configuration files, language files and text “dumps” of all the parameters shown on the MMI.

Configuration files and language files are formatted as Intel Hex files. The files contain a copy of the drive’s configuration and may be transferred either from the drive to the host computer, or from the host computer to the drive. **Transferring a configuration file to the drive will over-write all the drive’s settings.**

Language files contain information required to display parameters on the Display/Keypad in a language other than English. These may only be transferred from the host computer to the drive. Contact Parker for further information.

MMI dumps are human readable text files showing all the parameters in the drive in the order they are shown on the MMI. The files can only be transferred from a drive to the host computer.

## System Port (P3) Set-up

When transferring data using UDP the communications settings used are:

Baud rate selected via the P3 BAUD RATE parameter, (Tag No 198).

1 Stop bit, (fixed)

No Parity, (fixed)

8 data bits, (fixed)

No flow control, (fixed)

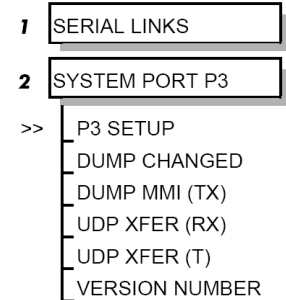
## UDP Transfer Procedure

### UDP XFER (RX)

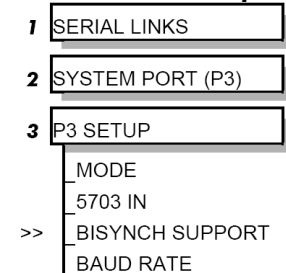
This is the transfer of either a language or a configuration file from the host computer to the Drive. The drive automatically detects whether the file is a language file or a configuration file. **Transferring a configuration file to the drive will over-write all the drive’s settings.**

1. Connect the Drive to the host using the appropriate lead.
2. Using a standard communications package prepare the host to transfer an ASCII file. Remember to set-up the host's serial port first.
3. Start the transfer on the Drive by selecting UDP XFER (RX) on the MMI and pressing the UP (↑) key, as instructed.
4. When the Drive says RECEIVING, begin the file transmission.
5. The Drive automatically terminates the UDP transfer when it detects the end of the Intel Hex end-of-file record.

### MMI Menu Map



### MMI Menu Map



**NOTE** When transferring a UDP configuration file from version of the 590 or 590P earlier than 8.1 then the following parameters are ignored:

Tag	Block	Parameter
18	AUTOTUNE	AUTOTUNE
120	MENUS	ENTER PASSWORD
138	MAIN PORT (P1)	GROUP ID (GID)
139	MAIN PORT (P1)	UNIT ID (UID)
140	AUX PORT (P2)	GROUP ID (GID)
141	AUX PORT (P2)	UNIT ID (UID)
142	MAIN PORT (P1)	PNO.7
143	AUX PORT (P2)	PNO.7
144	MAIN PORT (P1)	CHANGEBAND (BIN)
145	AUX PORT (P2)	CHANGEBAND (BIN)
146	MAIN PORT (P1)	ENABLED
147	AUX PORT (P2)	ENABLE
148	MAIN PORT (P1)	MODE
149	AUX PORT (P2)	MODE
150	MAIN PORT (P1)	BAUD RATE
151	AUX PORT (P2)	BAUD RATE
152	MAIN PORT (P1)	ESP SUP.(ASCII)
153	AUX PORT (P2)	ESP SUP.(ASCII)
158	MAIN PORT (P1)	ERROR REPORT
159	AUX PORT (P2)	ERROR REPORT
303	MAIN PORT (P1)	OPTION VERSION
328	SYSTEM PORT (P3)	ESP SUP.(ASCII)
331	SYSTEM PORT (P3)	CHANGEBAND (BIN)
332	SYSTEM PORT (P3)	ERROR REPORT
333	SYSTEM PORT (P3)	PNO.7
334	MAIN PORT (P1)	PARITY
499	MAIN PORT (P1)	OPTION ADDRESS
536	SEQUENCING	REM.SEQUENCE
543	CALIBRATION	ZERO CAL INPUTS
555	CALIBRATION	SCALE CAL INPUTS
609	AUTOTUNE	METHOD

## UDP XFER (TX)

This is the transfer of the drive's settings as an Intel Hex file.

1. Connect the Drive to the host using the appropriate lead.
2. Using a standard communications package prepare the host to receive an ASCII file. Remember to set up the host's serial port first.
3. On the host computer, direct data received on the serial comms port to a file.
4. Start the transfer on the Drive by selecting UDP XFER (TX) on the MMI and pressing the UP (↑) key, as instructed. The drive says SENDING.
5. When the transfer is finished, terminate the capture of serial data on the host computer.



### **MMI Dump Procedure**

The MMI dump can be used to transfer all of the drive's parameters or just those that have been changed from the default values. The format of the data is human readable and may be used as documentation of the drive's configuration.

#### **DUMP CHANGED**

This parameter is used in conjunction with DUMP MMI (TX). When TRUE, only those parameters that have been modified from their default value are included in the dump.

#### **DUMP MMI (TX)**

This is the transfer of all parameters.

1. Connect the Drive to the host using the appropriate lead.
2. Using a standard communications package prepare the host to receive an ASCII file. Remember to set up the host's serial port first.
3. On the host computer, direct data received on the serial comms port to a file.
4. Start the transfer on the Drive by selecting DUMP MMI (TX) on the MMI and pressing the UP (↑) key, as instructed. The drive says REQUESTED..
5. When the transfer is finished, terminate the capture of serial data on the host computer.

---

## DSELite Support

This is Parker's Windows-based block programming software. It has a graphical user interface and drawing tools to allow you to create block programming diagrams quickly and easily. Go go [www.parker.com/ssd](http://www.parker.com/ssd) for updates.

### System Port (P3) Set-up

Set MODE parameter (Tag No. 130) to EIASCII using the MMI

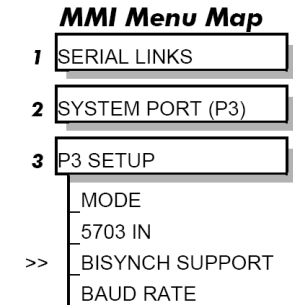
Set the BAUD RATE parameter to match the baud rate selected on the host computer.

1 Stop bit (fixed)

Even Parity (fixed)

7 bits (fixed)

No flow control, (fixed)



## 5703 Support

The 5703 Setpoint Repeater Unit provides the facility to run a line of drives in speed-lock without the use of a 5720 Quadraloc controller; for accurate speed-holding, encoder feedback is required. Ratioed speed-locking is supported, although the unit is not intended to replace the Quadraloc in applications requiring high accuracy.

A 16-bit speed signal is passed between drives via the P3 port on each Drive (a port otherwise used only off-line for the upload and download of EEPROM data). The port operates RS232 compatible signal levels. The 5703/1 converts these signal levels to fibre optic signals for transmission, and from fibre optics to RS232 for reception. Alternatively an external converter may be used to provide galvanic isolation and to convert the signals to RS485 for transmission over longer distances than is recommended for RS232.

### Hardware Description

The 5703 is housed in a DIN rail mounted box and is provided with a cable to connect into the P3 port. The cable is 400mm long to limit transmission errors, the primary unit-to-unit interconnection is intended to be achieved by a fibre optic cable.

The 5703 unit itself is simply an electric signal-to-light converter and does not alter the signal in any way, this is achieved within the software data of the Drive.

It is fitted with one fibre optic receiver and two fibre optic transmitters, the fibre optic receiver has a fixed function to receive data from the preceding unit while the transmitter sends data to the following unit. The additional transmitter can be used either to re-transmit the incoming signal or provide a second transmission of the output signal, this gives the unit wide functionality. When the link is in the normal right hand position, assuming the board is mounted with the fibre optics downward, the second transmitter repeats the output signal. In the left hand position it repeats the input signal.

The 5703/1 can be configured to point to any relevant parameter in the block diagram, the default connections are such that the scaled input is connected to the "additional speed demand" and the output to the "speed demand".

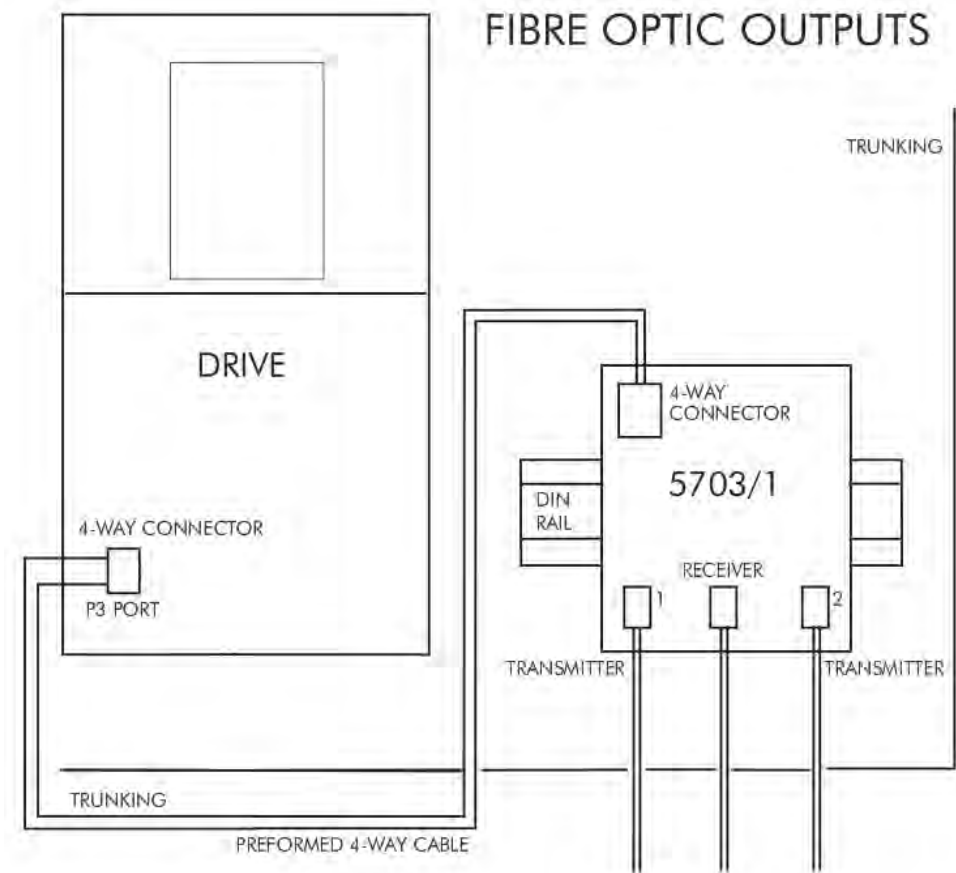


Figure A- 1 5703/1 Product Outline Drawing

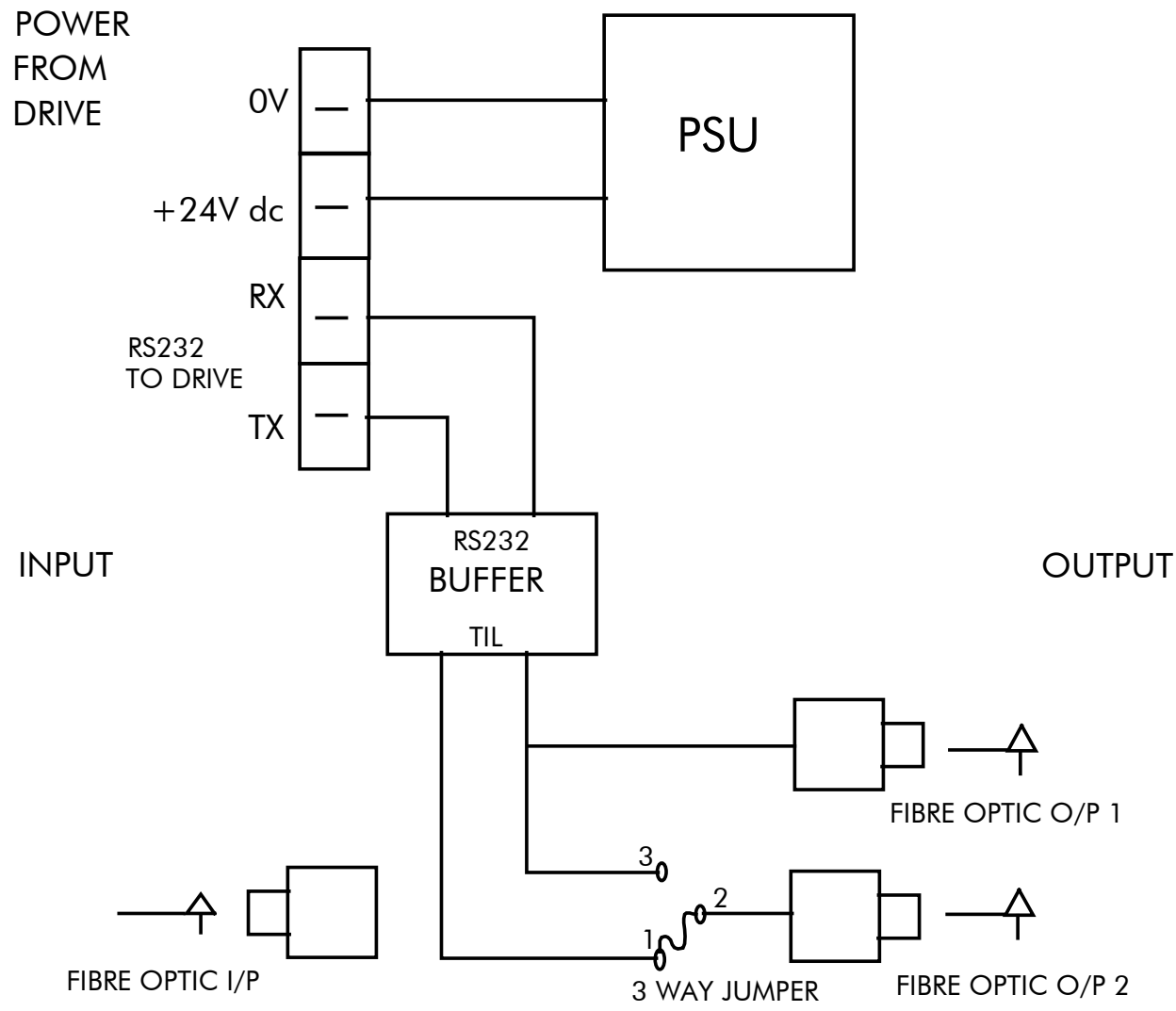


Figure A- 2 Wiring Diagram for 5703/1 Speed Repeater

## System Port (P3) Set-up

Set MODE parameter (Tag No. 130) to 5703 SLAVE or 5703 MASTER using the MMI

Set BAUD RATE parameter (Tag No. 198) to the required baud rate using the MMI. The baud rate must be the same on both the transmitting and the receiving drives.

1 Stop bit (fixed)

NO Parity (fixed)

8 bits (fixed)

No flow control, (fixed)

## Commissioning the 5703/1

### Input to the Drive

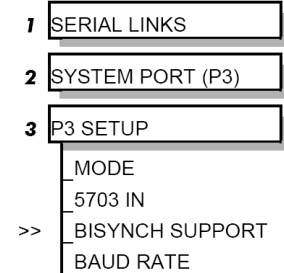
The speed setpoint from the 5703/1 enters the drive via the P3 port and, after scaling, is presented to the application as the parameter 5703 IN::SCALED INPUT. In the default application, this is added to analogue inputs 1, 2 and 3, (ramped), to form the setpoint. IN BASIC TACHO-FOLLOWER MODE, ALL THE ANALOG INPUTS MUST BE DISABLED TO PREVENT LOSS OF ACCURACY, yet it may be necessary in some applications to provide analog inputs for trim signals or inch setpoints:

1. The ramp input may be disabled by taking terminal C7 (Ramp Hold) permanently high; the ramp is automatically cleared when the drive is quenched, and its output will never move from (exactly) zero. The ramp input may often be of use in line master drives; but the ramp should be disabled in slave drives. Note that the P3 setpoint may be passed through the ramp function; in such a case, the analog input to the ramp (terminal A4) is automatically disconnected.
2. Analog input 1 (terminal A2) is used for inch setpoints. During normal running, the terminal is shorted to 0V and the deadband function is used so that no signal at all passes to the summing junction. The analog inch setpoints are set a little above the threshold of the deadband so as to give the required inching speeds, forward or backward. Selection between analog inching and absolutely zero analog input is thus accomplished automatically.
3. Analog input 2 (terminal A3) may be disabled by writing zero to its scaling block; this will normally be done through the MMI at commissioning, but may be overridden by the serial link. Alternatively, this input may be used for a local analog trim.

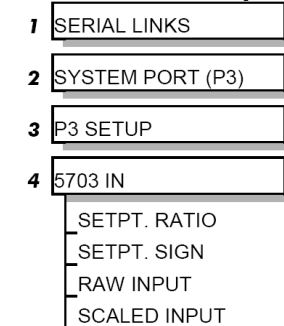
### Output from the Drive

By default, the value transmitted from the drive is the SPEED DEMAND parameter.

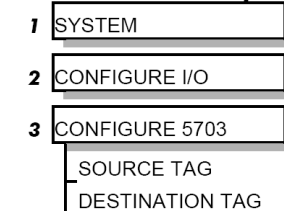
#### MMI Menu Map



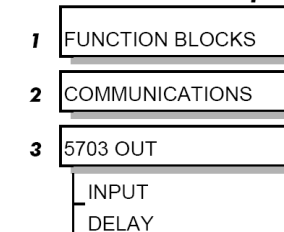
#### MMI Menu Map



#### MMI Menu Map



#### MMI Menu Map



## EI Bisynch ASCII Support

The drive can communicate using the EI Bisynch ASCII protocol without the need for a Technology Option board to be fitted.

**NOTE** The P3 port is not physically compatible with a multi-point network.

This communications protocol comes under the heading of Binary Synchronous Communications Data Link Control (BSCDLC). This is all part of an internationally recognised ANSI standard protocol called BISYNCH (Binary Synchronous) and is known by the abbreviation x3.28. It is widely used by manufacturers of computers, computer peripherals, and communications equipment.

EI BISYNCH, the specific form of communication used, corresponds with the following full American National Standard definition:

- ANSI Standard: x3.28, Revision: 1976
- Establishment and Termination Control Procedures Sub-category 2.5:  
*Two-way Alternate, Non-switched Multi-point with Centralised Operation & Fast Select*
- Message Transfer Control Procedure Sub-category B1:  
*Message Associated Blocking with Longitudinal Checking & Single Acknowledgement*

This is known by the abbreviation ANSI - x3.28 - 2.5 - B1.

### Features

- Configured using Function Block inputs
- Diagnostics using Function Block outputs
- Software-selectable Baud Rate
- Software-selectable Slave Address
- Direct tag access for all parameters

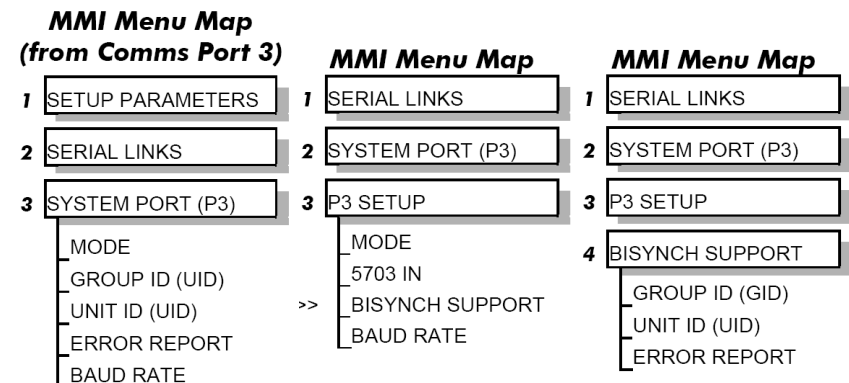
### System Port (P3) Set-up

Set MODE parameter (Tag No. 130) to **EIACSII** using the MMI

Set BAUD RATE parameter (Tag No. 198)

Set the GROUP ID parameter (the Parker SSD Drives protocol group identity address) to match the drive being communicated with.

Set the UNIT ID parameter (the Parker SSD Drives protocol unit identity address) to match the drive being communicated with.



## A-10 Serial Communications

For details of the EI Bisynch Protocol refer to the RS485 Communications Interface Technical Manual, HA463560U002. This is available for download on the Parker SSD Drives website, [www.parker.com/ssd](http://www.parker.com/ssd)

### EI Bisynch ASCII Parameter Mapping

#### 1. EI Bisynch ASCII Prime Set

The following prime set parameters are supported:

Mnemonic	Description	Range (HEX encoding)	Access
!I	Instrument Identity	>0690, >0605 or >5900	Read Only
V0	Main Software Version	>0000 to >FFFF	Read Only
V1	Keypad Software Version	>0000 to >FFFF (>0000 if not fitted)	Read Only
V2	Technology Box Software Version	>0000 to >FFFF	Read Only
EE	Last Error Code	>0000 to >FFFF (Writing any value resets this to >00C0)	Read/Write

#### 2. Command/Status

The following Command/Status parameters are supported:

Mnemonic	Description	Range (Hex encoding)	Access
!1	Command	see below	Write Only
!2	State	see below	Read Only
!3	Save Command	see below	Write Only
!4	Save State	see below	Read Only

<b><i>!1 : Command</i></b>	
Write-only: used to modify the state of the Inverter and to load configuration data from non-volatile memory.	
HEX Value	Description
>7777	Reset Command. Acknowledges failed restore. Loads and saves (590 does not save) default Product Code and default Configuration (Macro 1).
>0101	Restores Saved Configuration from drive's non-volatile memory.
>0111	Restores Default Configuration
>4444	Exit Configuration Mode
>5555	Enter Configuration Mode
<b><i>!2 : State</i></b>	
Read-only: used to determine the major state of the Inverter.	
HEX Value	Description
>0000	Initialising. (Powering up )
>0001	Corrupted Product Code and Configuration
>0002	Corrupted Configuration
>0003	Restoring Configuration
>0004	Re-Configuring Mode
>0005	Normal Operation Mode
<b><i>!3 : Save Command</i></b>	
Write-only: used to save the configuration and product code in non-volatile memory.	
HEX Value	Description
>0000	Reset Command. Acknowledges (clears) any previous save error.
>0001	Saves Configuration to drive's non-volatile memory.
<b><i>!4 : Save State</i></b>	
Read only: used to determine the progress of a non-volatile saving operation.	
HEX Value	Description
>0000	Idle
>0001	Saving
>0002	Failed



### 3. Tag Access

Each parameter in the Inverter's menu system is identified by a unique Tag Number. Information is exchanged across the system by use of a two character Mnemonic that is derived from the Tag Number.

**NOTE** Refer to the Parameter Specification Table in Appendix D for a full list of tag mnemonics - see the MN column. Refer to the Notes column which gives access information about each parameter.

#### *Parameter Mapping*

The algorithm to convert between tag number and 2 character mnemonics is:

```
if (TagNo < 936) then
  m = INT ((TagNo + 360)/36) (INT: the integer part)
  n = (TagNo + 360) MOD 36 (MOD: the remainder)
  if m > 9 then
    char_1 = 'a' + (m - 10)
  else
    char_1 = '0' + m
  end_if
  if n > 9 then
    char_2 = 'a' + (n - 10)
  else
    char_2 = '0' + n
  end_if
else
  m = INT ((TagNo - 936)/26) (INT: the integer part)
  n = (TagNo - 936) MOD 26 (MOD: the remainder)
  char_1 = 'a' + m
  char_2 = 'A' + n
end_if
```

The algorithm generates mnemonics containing only the characters '0' to '9', 'A' to 'Z' and 'a' to 'z'.

### 4. PNO Access

For compatibility with the earlier 590 product, parameters may also be accessed using the ASCII PNO listed in the "EI Bisynch Binary Parameter Specification Tables", page A-20. For example, PNO 39 can be accessed with the mnemonic "27".

## 5. Encoding

Type	Description	Encoding	Comments
BOOL	Boolean	FALSE >00 TRUE >01	Will accept >0 and >1
WORD	16-bit Bitstring	>0000 to >FFFF	Will accept leading zero suppression, except >0
INT	32-bit Signed Integer	-XXXX. to XXXX. -XXXX.X to XXXX.X -XXXX.XX to XXXX.XX -XXXX.XXX to XXXX.XXX -XXXX.XXXX to XXXX.XXXX	Leading zeroes suppressed up to digit before decimal point.  Trailing zeroes suppressed after decimal point.
ENUM	Enumerated Value ( 0 to 99)	>00 to >FF	Leading zeroes suppressed, except >0.
TAG	Tag No.	-XXXX. to XXXX. or 0. to XXXX.	As INT above. Source tag numbers may be set negative to indicate a feedback link, used to break a loop of function blocks.

*Note: The “.” in the above formats is not optional. It **must** be sent to conform to the EI-BISYNCH standard.*

## EI Binary Support

This mode has many similarities with the ASCII mode, and so what follows is a summary of the differences to the ASCII mode.

### Character Format

Each byte is transmitted as 11 bits rather than adapting the 10-bit format used by the ASCII mode. The format is represented by the following:-

1	Start bit (low)	
7	Data bits (LSB first)	
1	Control bit *	
1	Even parity bit	
1	Stop bit (high)	* 0 = Control character, 1 = Data character

### How is the Information Transferred?

During serial communications, Drive acts as a slave and responds to messages sent from the Supervisor. Messages received from the Supervisor are categorised into Main Messages and Continuation Messages.

The Binary mode introduces several different Control and Data Characters. Refer to “[EI Bisynch ASCII Support.](#)”

### Response to a ‘Selection’ Message

The response is very similar to the ASCII mode but differs in that the ASCII (GID)/(UID) address is replaced by the Binary (INO), Instrument Number. Also, the ASCII parameter mnemonic (C1)(C2) is replaced by the Binary (PNO) character.

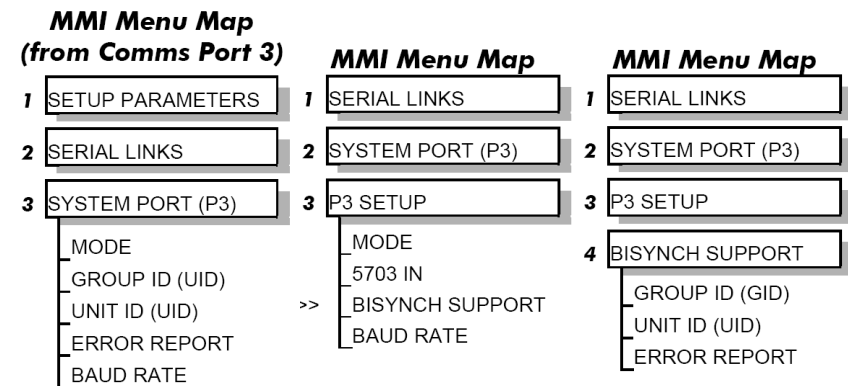
### System Port (P3) Set-up

Set MODE parameter (Tag No. 130) to **EIBINARY** using the MMI

Set BAUD RATE parameter (Tag No. 198)

Set the GROUP ID parameter (the Parker SSD Drives protocol group identity address) to match the drive being communicated with.

Set the UNIT ID parameter (the Parker SSD Drives protocol unit identity address) to match the drive being communicated with.



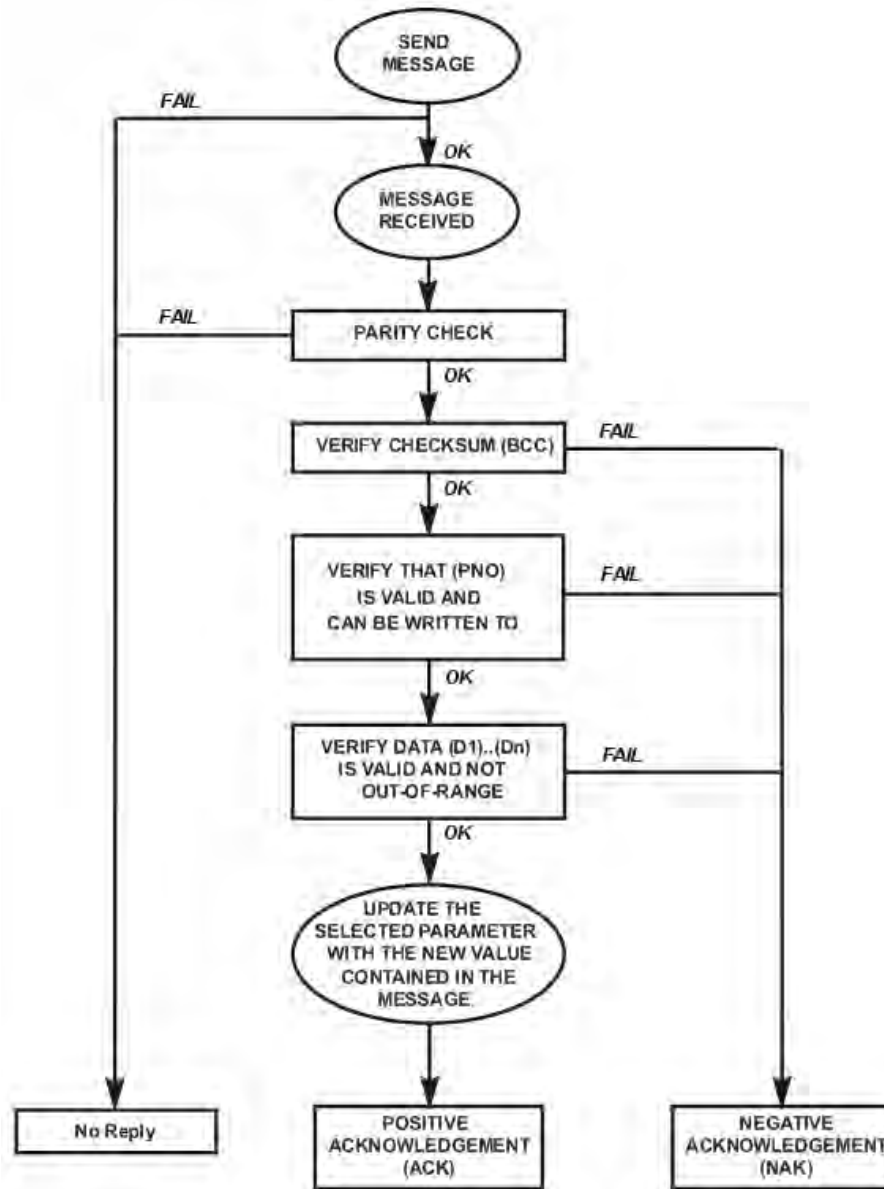


Figure A-3 Converter Response Sequence to a Binary Selection Message

## EI Bisynch Binary Message Protocol

<b>Transmission Standard</b>	:	RS485 (RS422 bi-directional)
<b>Protocol</b>	:	ANSI-X3.28-2.5-B1
<b>Data Rates</b>	:	300, 600, 1200, 2400, 4800, 9600, 19200, 38400, 57600 or 115200 Baud
<b>Character Format</b>	:	1 start + 8 bit ASCII data + 1 parity + 1 stop bit (11 bits)
<b>Parity</b>	:	Even

### Transferring Data - Binary Example Messages

There are two message types:

1. Main Messages
2. Continuation Messages

#### Main Messages

The main messages are in four types:

#### SELECTION

The Supervisor writes to one parameter. The (BCC) character contains the checksum of all characters following the (STX).

(EOT)	(INO)	(CCC)	(STX)	(PNO)	(D1)	(D2)	(D3)	(ETX)	(BCC)
-------	-------	-------	-------	-------	------	------	------	-------	-------

#### POLLING

The Supervisor requests to read the value of one parameter.

(EOT)	(INO)	(PNO)	(CCC)	(ENQ)
-------	-------	-------	-------	-------

#### ENQUIRY POLLING

The Supervisor requests to read all parameters in block 1.

(EOT)	(INO)	(CCC)	(ENQ)
-------	-------	-------	-------

#### MULTI-PARAMETER POLLING

The Supervisor requests to read a given number of parameters. That number is referred to as the count number (CNO), it is included in the request message and the reply will be sent by the drive, in blocks of up to 8 parameters.

(EOT)	(INO)	(PNO)	(CNO)	(CCC)	(ENQ)
-------	-------	-------	-------	-------	-------

**NOTE**

The (CCC) is the checksum of the characters following an (EOT) and is therefore equal to (INO) in Selection and Enquiry Polling messages.

## Continuation Messages

There are two types of continuation messages sent by the Supervisor:

### **NEXT (send next item from a list)**

Only valid if sent following a multi-parameter poll.

(ACK)

### **REPEAT (repeat last response)**

Only valid if sent following any type of poll. It requests a repetition of the previous response.

(NAK)

## Serial Transmission Responses

### **SELECTION MESSAGE RESPONSE (one character)**

Sent after the correct reception of a Selection message.

(ACK)

### **FAULT DETECTION RESPONSE (one character)**

Sent in the case of detecting a fault.

(NAK) or (EOT)

### **POLLING MESSAGE RESPONSE (more than one character)**

(STX) (PNO) (D1) (D2) (D3) (ETX) (BCC)

### **MULTI-POLLING MESSAGE RESPONSE (more than one character)**

The response can consist of a group of messages (blocks). The (ETX) character is only sent at the end of the last block (as for Polling Message Response above).

For other blocks, the (ETX) is replaced by an (ETB) to indicate an end of a block rather than the end of the response.

## Control Character Definitions

Standard Control Character Definitions	
(EOT)	End of Transmission (commands the slave to stop transmitting and wait to be addressed)
(STX)	Start of Text.
(ENQ)	Enquiry (sent by the master as the last character of any type of polling message)
(ETX)	End of Text (is followed by the checksum)
(ETB)	End of Block (sent instead of (ETX) when replying to a multi parameter enquiry). It indicates the end of a block, but not the end of a message.
(ACK)	Positive Acknowledgement
(NAK)	Negative Acknowledgement

## Data Character Definitions

Standard Data Character Definitions	
(INO)	Instrument Number (contains the address of the slave drive and is equivalent to the combination of the GID, UID characters of the ASCII mode)
(PNO)	Parameter Number (equivalent to the combination of the (C1) and (C2) characters of the ASCII mode and is sent as a hexadecimal number rather than two ASCII characters)
(D1), (D2) and (D3)	<p>These characters include the mode name and value read from, or to be written to, one of the parameters. A data character is represented by setting its MSB (bit 7). The contents of these characters are as follows:</p> <p style="margin-left: 40px;">D1 :            bits 2 [→]            6            mode number</p> <p style="margin-left: 80px;"><i>Number format is:</i></p> <p style="margin-left: 100px;">0 = XXXX</p> <p style="margin-left: 100px;">1 = XXX.X</p> <p style="margin-left: 100px;">2 = XX.XX</p> <p style="margin-left: 100px;">3 = X.XXX</p> <p style="margin-left: 100px;">4 = .XXXX</p> <p style="margin-left: 80px;">bits 0 and 1            bits 14 and 15 of the value.</p> <p style="margin-left: 40px;">D2 :            bits 0 [→] 6            bits 7 to 13 of the value.</p> <p style="margin-left: 40px;">D3 :            bits 0 [→] 6            bits 0 to 6 of the value.</p>
(CCC)	Connection Check Control (contains the checksum of all the characters following the (EOT) character in the message)
(BCC)	Block Check Character (checksum value generated by taking the exclusive OR (XOR) of the ASCII values of all characters transmitted after and excluding (STX) up to and including (ETX).

## List of PNO Assignments

The serial link parameter numbers (PNO) include dedicated parameters, and also 16 configurable parameters. These vary with each Drive type.

### *590+ and 590+DRV*

The 16 configurable parameters have PNO's 112 to 127. These can be made to point to any TAG number, either via the MMI (PNO CONFIG), or via the serial link.

PNO's 96 to 111 are pointers associated with PNO's 112 to 127.

For example:

**If** PNO 96 = 123, then PNO 112 will access TAG number 123.

**If** PNO 100 = 234, then PNO 116 will access TAG number 234

### *Enquiry Polling*

In Enquiry Polling mode, block 1 is polled.

### **MMI Menu Map**

1 SERIAL LINKS

2 PNO CONFIG

PNO 112  
PNO 113  
PNO 114  
PNO 115  
PNO 116  
PNO 117  
PNO 118  
PNO 119  
PNO 120  
PNO 121  
PNO 122  
PNO 123  
PNO 124  
PNO 125  
PNO 126  
PNO 127



## EI Bisynch Binary Parameter Specification Tables

Block 0		
PNO	ACCESS	DESCRIPTION
0	R/O	Instrument Identifier. Same as ASCII mnemonic II.
1	R/W	Error report. Same as ASCII mnemonic EE
2	R/O	Drive Software Version Number.

Block 1								
PNO (ID) BINARY	(MN) ASCII	TAG	DATA FORMAT			LIMITS MIN TO MAX	ACCESS	DESCRIPTION
			BIT	ASCII	BINARY			
8	08	063	-	21	xxx.xx		R/O	Speed Setpoint
9	09	089	-	21	xxx.xx		R/O	Speed Demand
10	0A	062	-	21	xxx.xx		R/O	Speed Feedback
11	0B	066	-	21	xxx.xx		R/O	Current Demand
12	0C	065	-	21	xxx.xx		R/O	Current Feedback
13	0D	183	-	21	xxx.xx		R/O	Field Demand
14	0E	181	-	21	xxx.xx		R/O	Field Feedback
15	0F	115	-	23	xxxxx		R/O	Health Word
			0			0/1		OVERSPEED
			1			0/1		MISSING PULSE
			2			0/1		FIELD OVER I
			3			0/1		Heatsink Over Temperature
			4			0/1		Motor Over Temperature
			5			0/1		OVER VOLTS (VA)
			6			0/1		Speed Feedback
			7			0/1		Encoder Failed
			8			0/1		Field Failed
			9			0/1		Three Phase Failed
			10			0/1		Phase Lock Loop
			11			0/1		5703 Receive Error
			12			0/1		Stall Trip
			13			0/1		Over Current Trip
			14			0/1		Cal. Card
			15			0/1		ACCTS Failed

<b>Block 2</b>								
PNO (ID) BINARY	(MN) ASCII	TAG	DATA FORMAT			LIMITS MIN TO MAX	ACCESS	DESCRIPTION
			BIT	ASCII	BINARY			
16	10	050	-	21	xxx.xx		R/O	Anin 1 (A2)
17	11	051	-	21	xxx.xx		R/O	Anin 2 (A3)
18	12	052	-	21	xxx.xx		R/O	Anin 3 (A4)
19	13	053	-	21	xxx.xx		R/O	Anin 4 (A5)
20	14	054	-	21	xxx.xx		R/O	Anin 5 (A6)
21	15	067	-	21	xxx.xx		R/O	Actual Pos I Lim
22	16	061	-	21	xxx.xx		R/O	Actual Neg I Lim
23	17	040	-	23	xxxxx		R/O	
-		068	0			0/1		Start Input
-		069	1			0/1		Jog Input
-		070	2			0/1		Enable Input
-		071	3			0/1		Digital Input 1
-		072	4			0/1		Digital Input 2
-		073	5			0/1		Digital Input 3
-		-	6			0/1		Program Stop Input
-		-	7			0/1		Coast Stop Input
-		074	8			0/1		Digital Output 1
-		075	9			0/1		Digital Output 2
-		076	10			0/1		Digital Output 3
-		-	11-15			0/1		Reserved

## A-22 Serial Communications

Block 3								
PNO (ID) BINARY	(MN) ASCII	TAG	DATA FORMAT			LIMITS MIN TO MAX	ACCESS	DESCRIPTION
			BIT	ASCII	BINARY			
24	18	030		21	xxx.xx	-200.00/200.00	R/W	Additional Current Demand
25	19	015		21	xxx.xx	0/200.00	R/W	Main Current Limit
26	1A	087		21	xxx.xx	0/200.00	R/O	+ve Current Clamp
27	1B	088		21	xxx.xx	0/200.00	R/O	-ve Current Clamp
28	1C	016		21	xxx.xx	0/200.00	R/W	Current Loop P Gain
29	1D	017		21	xxx.xx	0/200.00	R/W	Current Loop I Gain
30	1E	171		21	xxx.xx	0/100.00	R/W	Field Current Setpoint
31	1F	116		23	xxxxx		R/O	Health Store
				0		0/1		Over Speed
				1		0/1		Missing Pulse
				2		0/1		Field Over Current
				3		0/1		Fin Over Temperature
				4		0/1		Motor Over Temperature
				5		0/1		Field Over Volts
				6		0/1		Speed Feedback
				7		0/1		Encoder Fail
				8		0/1		Field Fail
				9		0/1		Three Phase
				10		0/1		Phase Lock Loop
				11		0/1		5703 Receive Error
				12		0/1		Stall Trip
				13		0/1		Over Current Trip
				14		0/1		Cal. Card
				15		0/1		ACCTS Failed.

Block 4								
PNO (ID) BINARY	(MN) ASCII	TAG	DATA FORMAT			LIMITS MIN TO MAX	ACCESS	DESCRIPTION
			BIT	ASCII	BINARY			
32	20	060	21		xxx.xx		R/O	Back EMF
33	21	058	21		xxx.xx		R/O	Analogue Tach
34	22	059	21		xxxxx		R/O	Encoder
35	23	064	21		xxx.xx		R/O	Speed Error
36	24	132	21		x.xxxx	-3.0000/3.0000	R/W	P3 Setpoint Ratio
37	25	014	21		xxx.xx	0/200.00	R/W	Speed Loop P Gain
38	26	013	21		xx.xxx	0.001/ 30.000	R/W	Speed Loop Time Constant (SEC)
39 *	27		23		xxxxx			
		161	0			0/1	R/W	Aux. Start
		168	1			0/1	R/W	Aux. Enable
			2.7				-	Reserved
		288	8			0/1	R/W	External Ramp Reset
		287	9			0/1	R/W	Auto Reset
		113	10				R/O	Ramping
		303	11			0/1	R/W	Reset Ramp to Speed Feedback

# A-24 Serial Communications

Block 5								
PNO (ID) BINARY	(MN) ASCII	TAG	DATA FORMAT			LIMITS MIN TO MAX	ACCESS	DESCRIPTION
			BIT	ASCII	BINARY			
40	28	006	21		x.xxxx	-3.0000/3.0000	R/W	Ratio 1
41	29	007	21		x.xxxx	-3.0000/3.0000	R/W	Ratio 2
42	2A	086	21		xxx.xx		R/O	Set Point Sum Output
43	2B	002	21		xxx.x	0.1/600.0	R/W	Ramp Accel. Time
44	2C	003	21		xxx.x	0.1/600.0	R/W	Ramp Decel. Time
45	2D	085	21		xxx.xx	-	R/O	Ramp Output
46	2E	041	21		xxx.xx	-100.00/100.00	R/W	Speed Setpoint 4
47	2F		23		xxxxx			
		082	0				R/O	Drive Start
		084	1				R/O	Drive Enable
		122	2				R/O	Health Flag
		125	3				R/O	Ready
			4 - 7					Reserved
		079	8				R/O	At Standstill
		112	9				R/O	Stall Trip Warning
			10 - 15					Reserved

Block 6								
PNO (ID) BINARY	(MN) ASCII	TAG	DATA FORMAT			LIMITS MIN TO MAX	ACCESS	DESCRIPTION
			BIT	ASCII	BINARY			
48	30	027	21		xxx.x	0.1/600.0	R/W	Stop time
49	31	026	21		xxx.x	0.1/600.0	R/W	P-Stop time
50	32	091	21		xxx.xx	0/200.00	R/W	P-Stop Current Limit
51	33	029	21		xxx.xx	0/100.00	R/W	Stop Zero Speed Threshold
52	34	005	21		xxx.xx	-100.00/100.00	R/W	Ramp Input
53	35	100	21		xxx.xx	-200.00/200.00	R/O	Setpoint Sum Input 1
54	36	309	21		xxx.xx	-200.00/200.00	R/W	Setpoint Sum Input 0
55	37		23		xxxxx			
		94	0			0/1	R/W	Aux. Digital Output 1
		95	1			0/1	R/W	Aux. Digital Output 2
		96	2			0/1	R/W	Aux. Digital Output 3
		-	3 - 7					Reserved
		292	8			0/1	R/W	Sign 0
		8	9			0/1	R/W	Sign 1
		9	10			0/1	R/W	Sign 2
			11 - 15					Reserved

Block 7								
PNO (ID) BINARY	(MN) ASCII	TAG	DATA FORMAT			LIMITS MIN TO MAX	ACCESS	DESCRIPTION
			BIT	ASCII	BINARY			
56	38	055	21		xxx.xx		R/O	Analogue Output 1
57	39	056	21		xxx.xx		R/O	Analogue Output 2
58	3A	128	21		xxx.xx	-100.00/100.00	R/W	Aux. Analogue Output 1
59	3B	129	21		xxx.xx	-100.00/100.00	R/W	Aux. Analogue Output 2
60	3C	266	21		xxx.xx	0/100.00	R/W	% S-Ramp
61	3D	264	21		xxx.xx		R/O	Raise / Lower Output
62	3E	255	21		xxx.xx	-300.00/300.00	R/W	Raise / Lower Reset Value
63	3F	-	23		xxxxx			
-		261	0			0 1	R/W	Raise / Lower Raise Input
-		262	1			0 1	R/W	Raise/Lower Lower Input
-		307	2			0 1	R/W	Raise / Lower Reset

## A-26 Serial Communications

Block 8								
PNO (ID) BINARY	(MN) ASCII	TAG	DATA FORMAT			LIMITS MIN TO MAX	ACCESS	DESCRIPTION
			BIT	ASCII	BINARY			
64	40	218		21	xxx.xx	-100.00/100.00	R/W	Jog Speed 1
65	41	219		21	xxx.xx	-100.00/100.00	R/W	Jog Speed 2
66	42	253		21	xxx.xx	-100.00/100.00	R/W	Take Up 1
67	43	254		21	xxx.xx	-100.00/100.00	R/W	Take Up 2
68	44	225		21	xxx.xx	-100.00/100.00	R/W	Crawl Speed
71	47	-		23	xxxxx			
-		228	0			0 1	R/W	Jog Mode
-		227	1			0 1	R/W	Auxiliary Jog

Block 9								
PNO (ID) BINARY	(MN) ASCII	TAG	DATA FORMAT			LIMITS MIN TO MAX	ACCESS	DESCRIPTION
			BIT	ASCII	BINARY			
72	48	208		21	x.xxxx	-3.0000/+3.0000 0	R/W	Ratio 0
73	49	309		21	xxx.xx	-100.00/+100.0 0	R/W	Input 0
74	4A	48		21	xxx.xx	-100.00/+100.0 0	R/W	Pre-set -ve Current Limit
75	4B	301		21	xxx.xx	-100.00/+100.0 0	R/W	Pre-set +ve Current Limit

Block 10								
PNO (ID) BINARY	(MN) ASCII	TAG	DATA FORMAT			LIMITS MIN TO MAX	ACCESS	DESCRIPTION
			BIT	ASCII	BINARY			
80	50	103		21	xxx.xx	-300.00 /+300.00	R/W	Value for TRUE Digital Input 1
81	51	104		21	xxx.xx	-300.00 /+300.00	R/W	Value for FALSE Digital Input 1
82	52	106		21	xxx.xx	-300.00 /+300.00	R/W	Value for TRUE Digital Input 2
83	53	107		21	xxx.xx	-300.00 /+300.00	R/W	Value for FALSE Digital Input 2
84	54	109		21	xxx.xx	-300.00 /+300.00	R/W	Value for TRUE Digital Input 3
85	55	110		21	xxx.xx	-300.00/+300.00	R/W	Value for FALSE Digital Input 3

Block 11								
PNO (ID) BINARY	(MN) ASCII	TAG	DATA FORMAT			LIMITS MIN TO MAX	ACCESS	DESCRIPTION
			BIT	ASCII	BINARY			
88	58	339	21		xxx.xx	-300.00/+300.00	R/W	Value 1
89	59	340	21		xxx.xx	-300.00/+300.00	R/W	Value 2
90	5A	341	21		xxx.xx	-300.00/+300.00	R/W	Value 3
91	5B	342	21		xxx.xx	-300.00/+300.00	R/W	Value 4
92	5C	343	21		xxx.xx	-300.00/+300.00	R/W	Value 5
93	5D	344	21		xxx.xx	-300.00/+300.00	R/W	Value 6
94	5E	345	21		xxx.xx	-300.00/+300.00	R/W	Value 7
95	5F	-	23		xxxxx			
-		346	0			0 1	R/W	Logic 1
-		347	1			0 1	R/W	Logic 2
-		348	2			0 1	R/W	Logic 3
-		349	3			0 1	R/W	Logic 4
-		350	4			0 1	R/W	Logic 5
-		351	5			0 1	R/W	Logic 6
-		352	6			0 1	R/W	Logic 7
-		353	7			0 1	R/W	Logic 8

Block 12								
PNO (ID) BINARY	(MN) ASCII	TAG	DATA FORMAT			LIMITS MIN TO MAX	ACCESS	DESCRIPTION
			BIT	ASCII	BINARY			
96	60	312	21		xxxxx		R/W	Pointer for PNO 112
97	61	313	21		xxxxx		R/W	Pointer for PNO 113
98	62	314	21		xxxxx		R/W	Pointer for PNO 114
99	63	315	21		xxxxx		R/W	Pointer for PNO 115
100	64	316	21		xxxxx		R/W	Pointer for PNO 116
101	65	317	21		xxxxx		R/W	Pointer for PNO 117
102	66	318	21		xxxxx		R/W	Pointer for PNO 118
103	67	319	21		xxxxx		R/W	Pointer for PNO 119



## A-28 Serial Communications

Block 13								
PNO (ID) BINARY	(MN) ASCII	TAG	DATA FORMAT			LIMITS MIN TO MAX	ACCESS	DESCRIPTION
			BIT	ASCII	BINARY			
104	68	320	21	xxxxx		R/W	Pointer for PNO 120	
105	69	321	21	xxxxx		R/W	Pointer for PNO 121	
106	6A	322	21	xxxxx		R/W	Pointer for PNO 122	
107	6B	323	21	xxxxx		R/W	Pointer for PNO 123	
108	6C	324	21	xxxxx		R/W	Pointer for PNO 124	
109	6D	325	21	xxxxx		R/W	Pointer for PNO 125	
110	6E	326	21	xxxxx		R/W	Pointer for PNO 126	
111	6F	327	21	xxxxx		R/W	Pointer for PNO 127	

Block 14								
PNO (ID) BINARY	(MN) ASCII	TAG	DATA FORMAT			LIMITS MIN TO MAX	ACCESS	DESCRIPTION
			BIT	ASCII	BINARY			
112	70	PNO 96	*	*	*	*	Configurable PNO 0	
113	71	PNO 97	*	*	*	*	Configurable PNO 1	
114	72	PNO 98	*	*	*	*	Configurable PNO 2	
115	73	PNO 99	*	*	*	*	Configurable PNO 3	
116	74	PNO 100	*	*	*	*	Configurable PNO 4	
117	75	PNO 101	*	*	*	*	Configurable PNO 5	
118	76	PNO 102	*	*	*	*	Configurable PNO 6	
119	77	PNO 103	*	*	*	*	Configurable PNO 7	

Block 15								
PNO (ID) BINARY	(MN) ASCII	TAG	DATA FORMAT			LIMITS MIN TO MAX	ACCESS	DESCRIPTION
			BIT	ASCII	BINARY			
120	78	PNO 104	*	*	*	*	Configurable PNO 8	
121	79	PNO 105	*	*	*	*	Configurable PNO 9	
122	7A	PNO 106	*	*	*	*	Configurable PNO 10	
123	7B	PNO 107	*	*	*	*	Configurable PNO 11	
124	7C	PNO 108	*	*	*	*	Configurable PNO 12	
125	7D	PNO 109	*	*	*	*	Configurable PNO 13	
126	7E	PNO 110	*	*	*	*	Configurable PNO 14	
127	7F	PNO 111	*	*	*	*	Configurable PNO 15	

\* = These fields depend upon the destination TAG number

## Error Codes

### ERROR REPORT (EE)

The EI-BISYNCH Prime Set contains the EE mnemonic. This is also an output parameter in the MAIN PORT (P1), AUX PORT (P2) and SYSTEM PORT (P3) function blocks, where the parameter value can be read and reset. Refer to the COMMS Option Technical Manual for further details.

The parameter displays the last error as a hexadecimal code. The following values are returned if an enquiry (reading information from the Drive) is performed on this Read/Write parameter.

Value	Description
>00C0	No error
>01C7	Invalid mnemonic
>02C2	Checksum (BCC) error
>03C2	Framing or overrun error
>04C8	Attempt to read from a write-only parameter
>05C8	Attempt to write to a read-only parameter
>07C7	Invalid message format
>07C8	Invalid data (encoding error)
>08C8	Data out of range

Writing any value to this parameter will set the value to >00C0 (No Error). Clearing the last error value may be useful in seeing a repetitive error re-occurring.

#### MMI Menu Map (from Comms Port 3)

1	SETUP PARAMETERS
2	SERIAL LINKS
3	SYSTEM PORT (P3)
	MODE
	GROUP ID (UID)
	UNIT ID (UID)
	ERROR REPORT
	BAUD RATE



# Appendix B Certification

## Introduction

### Europe

- What are the European Directives?
- CE Marking for the Low Voltage Directive (LVD) 2006/95/EC
- CE Marking for the EMC Directive 2004/108/EC

### United States of America & Canada

- Compliance
- Conditions for Compliance with UL508c

Solid-State Motor Overload Protection

Branch Circuit/Short Circuit Protection Requirements

Short Circuit Rating

Field Wiring Temperature Rating

Operating Ambient Temperature

Field Wiring Terminal Markings

Power and Control Field Wiring Terminals

Field Grounding Terminals

Field Terminal Kits

Recommended Wire Sizes

Field Grounding Terminals

Operating Ambient Temperature

External Power Semiconductor Protection Fuses

### Australia & New Zealand

- EMC Standards

### EMC

- Emissions Limits
- EMC General Installation Considerations

Earthing Requirements

- Increasing Motor Cable Length

### Certificates



# Introduction

Our Drives are certified as being compliant with the regulated market requirements in:

## *Europe*

Drives are CE certified as being compliant with

- The Low Voltage Directive 2006/95/EC
- The EMC Directive 2004/108/EC

## *USA*

- Underwriters Laboratory Standard UL508c for Power Conversion Equipment

## *Canada*

- Canadian Standards Association C22.2 No.14 for Industrial Control Equipment

## *Australia & New Zealand*

- CTick mark indicating EMC compliance is validated by compliance with the European Harmonised Standards for EMC

## *Rest of the world*

- Compliance may be certified for any countries where certification is based on CISPR (IEC) standards

## Europe

---

### What are the European Directives?

The Directives are created to allow manufacturers to trade freely within the EEC territory through technical harmonisation of entire product sectors, and by guaranteeing a high level of protection of public interest objectives. This is done by creating a CE marking **CE**, a "trade symbol" showing that the technical requirements and those for safety and health are met.

Business and industry are given a wide choice of how to meet their obligations. The European standards bodies have the task of drawing up technical specifications. Compliance with harmonised standards, of which the reference numbers have been published in the Official Journal and which have been transposed into national standards, provides presumption of conformity to the corresponding essential requirements of the EC directives.

Manufacturers are free to choose any other technical solution that provides compliance with the essential requirements. Compliance with harmonised standards remains voluntary and offers one route to complying with these essential requirements.

## B-2 Certification

The Declaration of Conformity signed by the companies nominated Compliance Officer is certification that the apparatus to which it refers meets the requirements of **all** the relevant European directives.

Compliance with harmonised standards provides a "presumption of conformity" and is the route which has been adopted by Parker SSD Drives.

---

### **CE Marking for the Low Voltage Directive (LVD) 2006/95/EC**

The Low Voltage Directive (LVD) 2006/95/EC<sup>1</sup> seeks to ensure that electrical equipment within certain voltage limits provides both a high level of protection for European citizens and enjoys a Single Market in the European Union. The Directive covers electrical equipment designed for use with a voltage rating of between 50 and 1000V for alternating current and between 75 and 1500V for direct current. For most electrical equipment, the health aspects of emissions of Electromagnetic Fields are also under the domain of the Low Voltage Directive.

The LVD is one of the oldest Single Market Directives which, in broad terms, provides both a conformity assessment procedure to be applied to equipment before being placed on the Market, and Essential Health Safety Requirements (EHSRs) which such equipment must meet either directly or by means of compliance with harmonized standards.

For electrical equipment within its scope, the Directive provides 'The Requirements' with respect to health and safety covering all risks, thus ensuring that electrical equipment is safe in its intended use.

In respect of conformity assessment, there is no third party intervention, as the manufacturer undertakes the conformity assessment. However, there are so-called "Notified Bodies" under the Directive, which may be used to provide reports in response to a challenge by a national authority as to the conformity of the equipment.

When installed in accordance with this manual, the product is CE marked by Parker SSD Drives in accordance with the Low Voltage Directive

Parker SSD Drives' certification (DoC) is supported by tests undertaken in accordance with harmonised standard BS EN61800-5-1

---

### **CE Marking for the EMC Directive 2004/108/EC**

The aim of the EMC Directive 2004/108/EC<sup>2</sup> is to ensure that any electric or electronic device will create no more than a limited amount of RF interference such that other apparatus are not prevented from functioning correctly, also to ensure that an electric or electronic device will withstand a certain amount of Electro Magnetic interference from within its working environment.

---

<sup>1</sup> *Directive 73/23/EEC has recently been the subject of a codification, requiring a new number 2006/95/EC. Readers should note that the text itself is identical.*

<sup>2</sup> *Directive 89/336/EEC has been superseded by Directive 2004/108/EC which came into effect on 15th December 2004.*

Provisions have been put in place so that:

- Equipment (apparatus <sup>3</sup> and fixed installations <sup>4</sup>) needs to comply with the requirements of the EMC Directive when it is placed on the market and/or taken into service.
- The application of good engineering practice is required for fixed installations, with the possibility for the competent authorities of Member States to impose measures if non-compliances are established.

The directive text makes a clear distinction between the requirements and assessment procedures for apparatus and for fixed installations respectively (fixed installations can include networks and large machines).

- Fixed installations, although they must comply with the protection requirements, require neither an EC Declaration of Conformity (DoC) nor CE marking;
- Mobile installations are considered apparatus.

The conformity assessment procedure for apparatus has been simplified to a single procedure. There is no compulsory involvement of a third party, but the manufacturer has the option of presenting his technical documentation to a Notified Body for assessment.

When deviating from the European harmonized standards or not applying them fully, the manufacturer has to perform an EMC assessment and provide detailed documentary evidence that the apparatus complies with the protection requirements of the EMC Directive.

Apparatus intended for a given fixed installation and not otherwise commercially available may be exempt from the requirements and procedures for apparatus (e.g. EC Declaration of Conformity and CE marking), provided that certain documentation requirements are met, including precautions to be taken in order not to compromise the EMC characteristics of the fixed installation.

BS EN 61800-3 defines the emissions and immunity levels for Power drive systems (PDS) and the main component parts of such a system (Basic drive module and Complete drive module).

The standard defines specific categories of PDS:

**PDS of Category C1**

PDS of rated voltage less than 1000V, intended for use in the first environment

**PDS of Category C2**

PDS of rated voltage less than 1000V, which is neither a plug in device nor a movable device and, when used in the first environment, is intended to be installed and commissioned only by a professional.

NOTE a professional is a person or organisation having necessary skills in installing and/or commissioning power drive systems, including their EMC aspects.

---

<sup>3</sup> *‘Apparatus’ means any finished appliance or combination thereof made commercially available as a single functional unit, intended for the end user and liable to generate electromagnetic disturbance, or the performance of which is liable to be affected by such disturbance.*

<sup>4</sup> *‘Fixed installation’ means a particular combination of several types of apparatus and where applicable other devices, which are assembled, installed and intended to be used permanently at a predefined location.*



## B-4 Certification

### **PDS of Category C3**

PDS of rated voltage less than 1000V, intended for use in the second environment and not intended for use in the first environment

### **PDS of Category C4**

PDS of rated voltage equal to or above 1000V, or rated current equal to or above 400A, or intended for use in complex systems in the second environment

The drive is generally a category C3 apparatus. Some of the equipments with higher ratings might be classified in Category C4; but for certification, and as an aid to builders of complex system, the emission limits and immunity levels associated with category C3 have been applied.

Parker SSD Drives' certification (DoC) is supported by tests undertaken in accordance with harmonised standard BS EN61800-3

# United States of America & Canada

---

## Compliance

The US have many municipalities that have laws, codes or regulations which require a product to be tested by a nationally recognized testing laboratory before it can be sold in their area. Parker SSD Drives adopt the nationally recognised Underwriters Laboratories (UL) mark to demonstrate compliance.

Products are also certified for the Canadian market obtained through UL and their memorandum of understanding with the Canadian Standards Agency (CSA).

Parker SSD Drives obtain product certification to UL508C “Power Conversion Equipment” for the US market, and C22.2 No.14 “Industrial Control Equipment” for the Canadian market.

---

## Conditions for Compliance with UL508c

### **Solid-State Motor Overload Protection**

**NOTE** An external motor overload protective device must be provided by the installer.

The maximum internal overload protection level (current limit) is 150% for 30 seconds and 200% for 10 seconds.

Motor overload protection is provided by means of the thermal device in the motor winding. This protection cannot be evaluated by UL, hence it is the responsibility of the installer and/or the local inspector to determine whether the overload protection is in compliance with the National Electrical Code or Local Code requirements.

## Branch Circuit/Short Circuit Protection Requirements

The controller requires branch circuit protection. Branch circuit protection requirements must be in accordance with the latest addition of the National Electrical Code, NEC/NFPA-70.

UL Recognized Component (JFHR2) semiconductor fuses with current ratings and maximum  $I^2t$  ratings as specified below must be used in the controller. Refer to the table below for the recommended fuse manufacturer and part number.

Motor HP @ 500V dc	Controller Rating (A)	Input Line Semiconductor Fuses			
		Ratings			Part No. Gould or equivalent*
		(Vac)	(A)	$I^2t$ (A <sup>2</sup> s)	
7.5	15	500	31.3	750	A60Q35
20	35	500	31.3	750	A60Q35
20	40	500	31.3	750	A60Q35
30	70	500	71.6	1300	A50QS80-4R
40	70	500	71.6	1300	A50QS80-4R
50	110	500	111.8	2860	A50QS125-4R
60	110	500	111.8	2860	A50QS125-4R
75	165	500	156.6	7540	A50QS200-4R
100	165	500	156.5	7540	A50QS200-4R
50 ●	180	500	?	?	
150	270	500	?	?	
					<b>Part No. Bussmann or equivalent*</b>
200	380	660	550	135000	170M6809
300	500	660	700	300000	170M6811
400	725	660	900	670000	170M6813
500	830	660	1000	945000	170M6814
900	1580	660	2 x 1000	945000	170M6814
<p>* Other UL Recognized Component (JFHR2) semiconductor fuses may be used in the controller provided that the voltage, ampere and <math>I^2t</math> ratings shown above are not exceeded.</p> <ul style="list-style-type: none"> <li>● Rated armature voltage: 240V dc</li> </ul> <p><b>NOTE</b> Semiconductor fuses are acceptable as branch circuit short-circuit protection for the solid-state motor controllers only.</p>					

**Table B- 1 Short Circuit Protection Requirements**

## B-6 Certification

### Short Circuit Rating

These products are suitable for use on a circuit capable of delivering not more than (the value shown in Table 12-2) RMS Symmetrical Amperes, 500V maximum.

Output Ratings		Short Circuit Rating RMS Symmetrical Amperes
(A)	(kW ) 500V	
15	7.5	5,000
35	15	5,000
40	15	10,000
70	30	10,000
110	45	10,000
165	75	10,000
380	150	18000
500	225	18000
725	327	30000
830	335	30000
1580	650	85000

**Table B- 2 Short Circuit Ratings**

### Field Wiring Temperature Rating

Use 75°C copper conductors only.

### Operating Ambient Temperature

For the operating ambient temperature range, refer to Appendix E: “Technical Specifications” - Environmental Details.

### Field Wiring Terminal Markings

For the correct field wiring connections that are to be made to each terminal, refer to Chapter 3: “Installing the Drive” - Electrical Installation.

### Power and Control Field Wiring Terminals

For the correct tightening torque value, refer to Appendix E: “Technical Specifications”.

## Field Grounding Terminals

The field grounding terminal(s) is identified with the International Grounding Symbol (IEC) Publication 417, Symbol 5019.

## Field Terminal Kits

UL compliant terminal kits are available for the connection of power wiring for the following Drive ratings. These terminals must be applied with the correct tooling as described in the Installation Instructions provided with each terminal kit.

Kit Part Number	Controller Rating (A)	Number of Lugs	Purpose	Lugs per Terminal	Wire Size per Lug	Cable Rating
LA386000U380	380	3	AC	1	2 x 4/0 AWG	230A
		2	DC	1	2 x 250kcmil	255A
LA386000U500	500	3	AC	1	2 x 300kcmil	285A
		2	DC	1	2 x 350kcmil	310A
LA386000U725	725	3	AC	1	2 x 600kcmil	420A
		4	DC	2	2 x 4/0 AWG	230A
LA386000U830	830	6	AC	2	2 x 250kcmil	255A
		4	DC	2	2 x 300kcmil	285A

**NOTE** 1580A controller requires two LA386000U830 kits.

## B-8 Certification

### Recommended Wire Sizes

North American wire sizes (AWG) are based on NEC/NFPA-70 for ampacities of thermoplastic-insulated (75°C) copper conductors assuming not more than three current-carrying conductors in raceway or cable, based on ambient temperature of 40°C. The wire sizes allow for an ampacity of 125% of the rated input and output amperes for motor branch-circuit conductors as specified in NEC/NFPA-70.


The table below gives the wire sizes for the input (supply) and output (motor) wiring. The table includes the rated input and output amperes for each model at 460V or 575V operation.

<b>Recommended Wire Sizes (Frames 1, 2, 3, 4 &amp; 5)</b>						
Main power wiring. Local wiring regulations always take precedence.						
Drive Size (A)	Input Current (A)	Input			Output	
		Number of Conductors	North American Wire Size	Output Current (A)	Number of Conductors	North American Wire Size
<b>Frame 1</b>						
15	13.5	1	12 AWG	15	1	12 AWG
35	28.35	1	8 AWG	35	1	8 AWG
<b>Frame 2</b>						
40	36	1	8 AWG	40	1	8 AWG
70	63	1	1 AWG	70	1	3 AWG
110	99	1	1 AWG	110	1	1/0 AWG
165	148.5	1	3/0 AWG	165	1	4/0 AWG
<b>Frame 3</b>						
180	162	1	4/0 AWG	180	1	4/0 AWG
270	243	1	350 Kcmil	270	1	500 Kcmil
<b>Frame 4 &amp; 5</b>						
380	342	1	700 Kcmil	380	1	750 Kcmil
500	450	1	1250 Kcmil	500	1	1500 Kcmil
725	653	1	3 inch bus bar	725	1	3 inch bus bar
830	747	1	3 inch bus bar	830	1	4 inch bus bar
1580	1427	2	4 inch bus bar	1580	2	4 inch bus bar

<b>Recommended Wire Sizes (Frame 6)</b>							
Local wiring regulations always take precedence.							
Description	Drive Size (A)	Input			Output		
		Input Current (A)	Number of Conductors	North American Wire Size (Kcmil)	Output Current (A)	Number of Conductors	North American Wire Size (Kcmil)
Main Power	1250	1125	4	500	1250	4	500
	1650	1485	6	400	1650	6	500
	1950	1755	6	500	1950	6	600
Field	60	60	1	AWG 8	60	1	AWG 8

<b>Recommended Wire Sizes (Frame 7)</b>							
Local wiring regulations always take precedence.							
Description	Drive Size (A)	Input			Output		
		Input Current (A)	Number of Conductors	North American Wire Size (Kcmil)	Output Current (A)	Number of Conductors	North American Wire Size (Kcmil)
Main Power	1200	1100	4	500	1200	4	500
	1700	1550	6	400	1700	6	500
	2200	2000	6	600	2200	6	700
	2700	2450	6	900	2700	8	700
Field	60	60	1	AWG 8	60	1	AWG 8

## Field Grounding Terminals

The field grounding terminals are identified with the International Grounding Symbol  (IEC Publication 417, Symbol 5019).

## Operating Ambient Temperature

0°C to 40°C (32°F to 104°F), derate up to a maximum of 50°C. Derate linearly at 1% per degree centigrade for temperature exceeding the maximum rating ambient for the drive.

## External Power Semiconductor Protection Fuses

For details on these input fuses, refer to Appendix E: "Technical Specifications".

## Australia & New Zealand

A Mutual Recognition Agreement in relation to conformity assessment, certificates and markings between Australia and the European Community was signed on June 1, 1998 and entered into force on January 1, 1999. Sectoral Annexes of the MRA cover: medicinal products, medical devices, telecommunications terminal equipment, low voltage equipment (i.e. electrical safety), electromagnetic compatibility (EMC), machinery, pressure equipment and automotive products.

### EMC Standards

Extract from Mandatory Australian Communications Authority standards.

Product	European	International	AS/NZS
Industrial, scientific, and medical (ISM) equipment	EN 55011	CISPR 11	2064 Note 3
Information technology equipment	EN 55022	CISPR 22	3548 Note 2
Generic (residential, commercial, and light industry)	EN 50081.1	IEC 61000-6-3	4251.1
Generic (industrial environments)	EN 50081-2	IEC 61000-6-4	4251.2
Adjustable speed electrical power drive systems	EN 61800-3	IEC 61800-3	0

Parker SSD certification (DoC) is supported by tests undertaken in accordance with harmonised standard BS EN61800-3

# EMC

## Emissions Limits

### Conducted

Frequency (MHz)	DB (µV)		Product Specific EN 61800-3
	Quasi Peak	Average	
where $I \leq 100A$ 0.15 - 0.5 0.5 - 5.0 5.0 - 30.0 <i>decreasing with log of frequency to:</i>	100 86 90 70	90 76 80 60	Category C3 Table 17
where $I \geq 100A$ 0.15 - 0.5 0.5 - 5.0 5.0 - 30.0	130 125 115	120 115 105	

### Harmonics (Low Frequency Emissions)

$I < 75A$       61000-3-12

$I > 75A$       61000-3-4

Harmonic emissions for DC drive installations cannot be predicted here as they are determined by motor parameters that are installation dependent. For help in determining the harmonics contact Parker SSD Drives.

Where these levels are too high and to ensure compatibility with other equipment, EMC filters are available from Parker SSD Drives.

### Radiated

Frequency (MHz)	DB (µV)	Product Specific
	Quasi Peak	EN 61800-3
$30 \leq f < 230$ $230 \leq f < 1000$	50 60	Category C3 (Table 18) Measured at 10m

Where these levels are too high and to ensure compatibility with other equipment, Parker SSD Drives can advise on suitable counter-measures.



## B-12 Certification

### EMC Immunity Levels

Port	Phenomenon	Basic standard for test method	Level	Performance (acceptance criterion)
Enclosure port	ESD	IEC 61000-4-2	4 kV CD or 8 kV AD if CD impossible	B
	Radio-frequency electromagnetic field, amplitude modulated.	IEC 61000-4-3 see also 5.3.4	80 MHz to 1000 Mhz 10 V/m 80% AM (1 kHz)	A
Power ports	Fast transient-burst	IEC 61000-4-4	2 kV/5 kHz <sup>a</sup>	B
	Surge <sup>b</sup> 1,2/50 μs, 8/20 μs	IEC 61000-4-5	1 kV <sup>c</sup> 2 kV <sup>d</sup>	B
	Conducted radio-frequency common mode <sup>e</sup>	IEC 61000-4-6 see also 5.3.4	0,15 MHz to 80 MHz 10 V 80 % AM (1 kHz)	A
Power interfaces	Fast transient-burst <sup>e</sup>	IEC 61000-4-4	2 kV/5 kHz Capacitive clamp	B
Signal interfaces	Fast transient-burst <sup>e</sup>	IEC 61000-4-4	1 kV/5 kHz Capacitive clamp	B
	Conducted radio-frequency common mode <sup>e</sup>	IEC 61000-4-6 see also 5.3.4	0,15 MHz to 80 MHz 10 V 80 % AM (1 kHz)	A
Ports for process measurement control lines	Fast transient-burst <sup>e</sup>	IEC 61000-4-4	2 kV/5 kHz Capacitive clamp	B
	Surge <sup>f</sup> 1,2/50 μs, 8/20 μs	IEC 61000-4-5	1 kV <sup>d,f</sup>	B
	Conducted radio-frequency common mode <sup>e</sup>	IEC 61000-4-6 see also 5.3.4	0,15 MHz to 80 MHz 10 V 80 % AM (1 kHz)	A
CD : contact discharge      AD : air discharge    AM : amplitude modulation				
<sup>a</sup> Power ports with current rating < 100 A: direct coupling using the coupling and decoupling network. Power ports with current rating ≥ 100 A: direct coupling or capacitive clamp without decoupling network. If the capacitive clamp is used, the test level shall be 4 kV/2,5 kHz. <sup>b</sup> Applicable only to power ports with current consumption , 63 A during light load test conditions as specified in 5.1.3. The rated impulse voltage of the basic insulation shall not be exceeded (see IEC 60664-1). <sup>c</sup> Coupling line-to-line. <sup>d</sup> Coupling line-to-earth. <sup>e</sup> Applicable only to ports or interfaces with cables whose total length according to the manufacturer's functional specification may exceed 3 m. <sup>f</sup> Applicable only to ports with cables whose total length according to the manufacturer's functional specification may exceed 30 m. In the case of a shielded cable, a direct coupling to the shield is applied. This immunity requirement does not apply to fieldbus or other signal interfaces where the use of surge protection devices is not practical for technical reasons. The test is not required where normal functioning cannot be achieved because of the impact of the coupling/decoupling network on the equipment under test (EUT).				

**Table B- 3 Minimum immunity requirements for PDSs intended for use in the second environment**

---

# EMC General Installation Considerations

## Earthing Requirements

**IMPORTANT** *Protective earthing always takes precedence over EMC screening.*

### Protective Earth (PE) Connections

**NOTE** In accordance with installations to EN60204, only one protective earth conductor is permitted at each protective earth terminal contacting point.

Local wiring regulations take precedence and may require the protective earth connection of the motor to be connected locally, i.e. not as specified in these instructions. This will not cause shielding problems because of the relatively high RF impedance of the local earth connection.

### EMC Earth Connections

For compliance with EMC requirements, we recommend that the “0V/signal ground” be separately earthed. When a number of units are used in a system, these terminals should be connected together at a single, local earthing point.

Control and signal cables for the encoder, all analogue inputs, and communications require screening with the screen connected only at the VSD (Variable Speed Drive) end. However, if high frequency noise is still a problem, earth the screen at the non-VSD end via a 0.1µF capacitor.

**NOTE** Connect the screen (at the VSD end) to the VSD protective earth point, and not to the control board terminals.

## Cabling Requirements

### *Planning Cable Runs*

- Use the shortest possible motor cable lengths.
- Use a single length of cable to a star junction point to feed multiple motors.
- Keep electrically noisy and sensitive cables apart.
- Keep electrically noisy and sensitive parallel cable runs to a minimum. Separate parallel cable runs by at least 0.25 metres. For runs longer than 10 metres, separation should be increased proportionally. For example if the parallel runs were 50m, then the separation would be  $(50/10) \times 0.25\text{m} = 1.25\text{m}$ .
- Sensitive cables should cross noisy cables at 90°.
- Never run sensitive cables close or parallel to the motor, dc link and braking chopper circuit for any distance.
- Never run supply, dc link or motor cables in the same bundle as the signal/control and feedback cables, even if they are screened.
- Ensure EMC filter input and output cables are separately routed and do not couple across the filter.

## B-14 Certification

### Increasing Motor Cable Length

Because cable capacitance and hence conducted emissions increase with motor cable length, conformance to EMC limits is only guaranteed with the specified ac supply filter option up to a maximum cable length as specified in Appendix E: "Technical Specifications".

This maximum cable length can be improved using the specified external input or output filters.

Screened/armoured cable has significant capacitance between the conductors and screen, which increases linearly with cable length (typically 200pF/m but varies with cable type and current rating).

Long cable lengths may have the following undesirable effects:


- Tripping on 'overcurrent' as the cable capacitance is charged and discharged at the switching frequency.
- Producing increased conducted emissions that degrade the performance of the EMC filter due to saturation.
- Causing RCDs (Residual Current Devices) to trip due to increased high frequency earth current.
- Producing increased heating inside the EMC ac supply filter from the increased conducted emissions.

These effects can be overcome by adding chokes or output filters at the output of the VSD.

# Certificates

Issued for compliance with the EMC Directive when the unit is used as *relevant apparatus*.

This is provided to aid your justification for EMC compliance when the unit is used as a *component*.

<b>DC590+ DRV</b>	
<b>CE</b>	
<b>EC DECLARATIONS OF CONFORMITY</b>	
Date CE marked first applied: 01.04.2001	
<b>EMC Directive</b>	<b>Low Voltage Directive</b>
In accordance with the EEC Directive 2004/108/EC	In accordance with the EEC Directive 2006/95/EC
We Parker SSD Drives, address as below, declare under our sole responsibility that the above Electronic Products when installed and operated with reference to the instructions in the Product Manual (provided with each piece of equipment) is in accordance with the relevant clauses from the following standard:- * BSEN61800-3 (2004)	We Parker SSD Drives, address as below, declare under our sole responsibility that the above Electronic Products when installed and operated with reference to the instructions in the Product Manual (provided with each piece of equipment), is in accordance with the relevant clauses from the following standard :- EN50178 (1993)
<b>MANUFACTURERS DECLARATIONS</b>	
<b>EMC Declaration</b>	<b>Machinery Directive</b>
We Parker SSD Drives, address as below, declare under our sole responsibility that the above Electronic Products when installed and operated with reference to the instructions in the Product Manual (provided with each piece of equipment) is in accordance with the relevant clauses from the following standard:- * BSEN61800-3 (2004)	The above Electronic Products are components to be incorporated into machinery and may not be operated alone. The complete machinery or installation using this equipment may only be put into service when the safety considerations of the Directive 2006/42/EC are fully adhered to. Particular reference should be made to EN60204-1 (Safety of Machinery - Electrical Equipment of Machines). All instructions, warnings and safety information of the Product Manual must be adhered to.
 _____ Dr Martin Payn (Conformance Officer)	
* Compliant with the immunity requirements of the Standard without specified EMC filters.	
<b>PARKER HANNIFIN MANUFACTURING LIMITED, AUTOMATION GROUP, SSD DRIVES EUROPE</b> NEW COURTWICK LANE, LITTLEHAMPTON, WEST SUSSEX BN17 7RZ TELEPHONE: +44(0)1903 737000 FAX: +44(0)1903 737100 Registered Number: 4806503 England. Registered Office: 55 Maylands Avenue, Hemel Hempstead, Herts HP2 4SJ	

The drive is CE marked in accordance with the low voltage directive for electrical equipment and appliances in the voltage range when installed correctly.

Since the potential hazards are mainly electrical rather than mechanical, the drive does not fall under the machinery directive. However, we do supply a manufacturer's declaration for when the drive is used (as a *component*) in machinery.

## B-16 Certification

# Appendix C **Parameter Specification Tables**

Details for all parameters provided on the Keypad.

Parameter Tables  
Specification Table: Tag Number Order

- Parameter Table: MMI Menu Order



# Parameter Tables

The headings for the Tag No. table are described below.

<b>Tag</b>	A numeric identification of the parameter. It is used to identify the source and destinations of internal links.																		
<b>Mn</b>	Serial Communications Mnemonic: Refer to Appendix A: "Serial Communications"																		
<b>MMI Block Name</b>	The menu page under which the parameter is stored on the MMI.																		
<b>MMI Parameter Name</b>	The parameter name as it appears on the MMI.																		
<b>Minimum/Maximum/Default/Units/Range</b>	<p>The Range varies with parameter type:</p> <p>INT    The upper and lower limits of the parameter, indicating the parameter's true, internally-held, number of decimal.</p> <p><b>Note:</b> Decimal Places - some internally held parameters with two decimal places are only displayed with one decimal place. These parameters are indicated in the Parameter Description tables. The Range parameter highlights these with "(h)".</p> <p>BOOL    0 = FALSE, 1 = TRUE</p> <p>WORD    0x0000 to 0xFFFF (hexadecimal)</p>																		
<b>Notes</b>	<p>Output parameters are not saved in non-vol memory unless noted otherwise. Input parameters are saved in non-vol memory unless noted otherwise.</p> <table border="0"> <tr> <td><b>View levels:</b></td> <td><b>Write qualifiers:</b></td> <td></td> </tr> <tr> <td>V0 Normal</td> <td>W0</td> <td>Always</td> </tr> <tr> <td>V1 Advanced</td> <td>W1</td> <td>Only when stopped</td> </tr> <tr> <td></td> <td>W2</td> <td>Only when in configuration mode</td> </tr> <tr> <td></td> <td>W3</td> <td>Only in thee-button reset mode</td> </tr> <tr> <td></td> <td>W4</td> <td>Read only, (output parameters)</td> </tr> </table>	<b>View levels:</b>	<b>Write qualifiers:</b>		V0 Normal	W0	Always	V1 Advanced	W1	Only when stopped		W2	Only when in configuration mode		W3	Only in thee-button reset mode		W4	Read only, (output parameters)
<b>View levels:</b>	<b>Write qualifiers:</b>																		
V0 Normal	W0	Always																	
V1 Advanced	W1	Only when stopped																	
	W2	Only when in configuration mode																	
	W3	Only in thee-button reset mode																	
	W4	Read only, (output parameters)																	

**Parameter Types:**

- Parameters that look like 0x0000 are WORDS
- Parameters that have text are BOOLs if they have a range of 0,1
- Parameters that have text are WORDS if their range is 0 to greater than 1
- All other parameters are INT (integers)

If a parameter can only be written to in Config mode, this implies that the drive is stopped.



## C-2 Parameter Specification Tables

# Specification Table: Tag Number Order

Tag	Mn	MMI Block Name	MMI Parameter Name	Minimum	Maximum	Default	Units	Range	Notes
2	a2	RAMPS	RAMP ACCEL TIME	0.1	600.0	10.0	s		V0 W0
3	a3	RAMPS	RAMP DECEL TIME	0.1	600.0	10.0	s		V0 W0
5	a5	MIN SPEED	RAMP INPUT	-105.00	105.00	0.00	%		V1 W0
6	a6	SETPOINT SUM 1	RATIO 1	-3.0000	3.0000	1.0000			V0 W0
7	a7	SPEED LOOP	RATIO 2 (A3)	-3.0000	3.0000	1.0000			V0 W0
8	a8	SETPOINT SUM 1	SIGN 1	0	1	1		0: NEGATIVE 1: POSITIVE	V1 W0
9	a9	SPEED LOOP	SIGN 2 (A3)	0	1	1		0: NEGATIVE 1: POSITIVE	V0 W0
10	aa	CALIBRATION	ZERO SPD. OFFSET	-5.00	5.00	0.00	%		V0 W0
11	ab	STANDSTILL	STANDSTILL LOGIC	0	1	0		0: DISABLED 1: ENABLED	V0 W0
12	ac	STANDSTILL	ZERO THRESHOLD	0.00	100.00	2.00	%		V0 W0
13	ad	SPEED LOOP	SPD.INT.TIME	0.001	30.000	0.500	s		V0 W0
14	ae	SPEED LOOP	SPD.PROP.GAIN	0.00	200.00	10.00			V0 W0
15	af	CURRENT LOOP	CUR.LIMIT/SCALER	0.00	200.00	100.00	%		V0 W0
16	ag	CURRENT LOOP	PROP. GAIN	0.00	200.00	45.00			V0 W0
17	ah	CURRENT LOOP	INT. GAIN	0.00	200.00	3.50			V0 W0
18	ai	AUTOTUNE	AUTOTUNE	0	2	0		0: OFF 1: ARMATURE 2: FIELD	V0 W0
19	aj	ALARMS	FIELD FAIL	0	1	0		0: ENABLED 1: INHIBITED	V0 W0
20	ak	CALIBRATION	ARMATURE V CAL.	0.9800	1.1000	1.0000			V0 W0
21	al	CALIBRATION	IR COMPENSATION	0.00	100.00	0.00	%		V0 W0
22	am	ENCODER 1	ENCODER RPM	0	6000	1000	RPM		V0 W1
23	an	CALIBRATION	ANALOG TACH CAL	0.9800	1.1000	1.0000			V0 W0
24	ao	ENCODER 1	ENCODER LINES	10	5000	1000			V0 W1
25	ap	CALIBRATION	ARMATURE I (A9)	0	1	1		0: UNIPOLAR 1: BIPOLAR	V0 W0
26	aq	STOP RATES	PROG STOP TIME	0.1	600.0	0.1	s		V0 W0
27	ar	STOP RATES	STOP TIME	0.1	600.0	10.0	s		V0 W0

## Parameter Specification Tables C-3

Tag	Mn	MMI Block Name	MMI Parameter Name	Minimum	Maximum	Default	Units	Range	Notes
28	as	ALARMS	STALL TRIP	0	1	0		0: ENABLED 1: INHIBITED	V1 W0
29	at	STOP RATES	STOP ZERO SPEED	0.00	100.00	2.00	%		V0 W0
30	au	CURRENT LOOP	ADDITIONAL DEM	-200.00	200.00	0.00	%		V1 W0
31	av	CURRENT PROFILE	SPD BRK2 (HIGH)	0.0	100.0	100.0	%		V0 W1
32	aw	CURRENT PROFILE	SPD BRK1 (LOW)	0.0	100.0	100.0	%		V0 W1
33	ax	CURRENT PROFILE	IMAX BRK2(SPD2)	0.0	200.0	200.0	%		V0 W1
37	b1	MENUS	VIEW LEVEL	0	2	1		0: BASIC 1: STANDARD 2: ADVANCED	V0 W0
39	b3	CONFIGURE DRIVE	CONFIGURE ENABLE	0	1	0		0: DISABLED 1: ENABLED	V0 W1
41	b5	SPEED LOOP	SETPOINT 4	-105.00	105.00	0.00	%		V0 W0
42	b6	CURRENT LOOP	AT CURRENT LIMIT	0	1	0			V1 W4
43	b7	DIGITAL OUTPUT 1	MODULUS	0	1	1			V0 W0
44	b8	DIGITAL OUTPUT 2	MODULUS	0	1	1			V0 W0
45	b9	DIGITAL OUTPUT 3	MODULUS	0	1	1			V0 W0
47	bb	SPEED LOOP	SPEED FBK SELECT	0	4	0		0: ARM VOLTS FBK 1: ANALOG TACH 2: ENCODER 3: ENCODER/ANALOG 4: ENCODER 2	V0 W1
48	bc	CURRENT LOOP	NEG. I CLAMP IN	-200.00	200.00	-200.00	%		V1 W0
49	bd	ENCODER 1	ENCODER SIGN	0	1	1		0: NEGATIVE 1: POSITIVE	V0 W1
50	be	ANALOG INPUT 1	ANIN 1 (A2)	0.00	0.00	0.00	V		V1 W4
51	bf	ANALOG INPUT 2	ANIN 2 (A3)	0.00	0.00	0.00	V		V1 W4
52	bg	ANALOG INPUT 3	ANIN 3 (A4)	0.00	0.00	0.00	V		V1 W4
53	bh	ANALOG INPUT 4	ANIN 4 (A5)	0.00	0.00	0.00	V		V1 W4
54	bi	ANALOG INPUT 5	ANIN 5 (A6)	0.00	0.00	0.00	V		V1 W4
55	bj	ANALOG OUTPUT 1	ANOUT 1 (A7)	0.0	0.0	0.0	V		V1 W4
56	bk	ANALOG OUTPUT 2	ANOUT 2 (A8)	0.0	0.0	0.0	V		V1 W4
57	bl	CALIBRATION	TERMINAL VOLTS	0.0	0.0	0.0	%		V1 W4
58	bm	CALIBRATION	UNFIL.TACH INPUT	0.0	0.0	0.0	%		V0 W4
59	bn	ENCODER 1	UNFIL.ENCODER	0	0	0	RPM		V0 W4

## C-4 Parameter Specification Tables

Tag	Mn	MMI Block Name	MMI Parameter Name	Minimum	Maximum	Default	Units	Range	Notes
60	bo	CALIBRATION	BACK EMF	0.0	0.0	0.0	%		V0 W4
61	bp	CURRENT LOOP	ACTUAL NEG I LIM	0.0	0.0	0.0	%		V0 W4
62	bq	SPEED LOOP	UNFIL.SPD.FBK	0.00	0.00	0.00	%		V0 W4
63	br	SPEED LOOP	SPEED SETPOINT	0.00	0.00	0.00	%		V0 W4
64	bs	SPEED LOOP	UNFIL.SPD.ERROR	0.00	0.00	0.00	%		V0 W4
65	bt	CURRENT LOOP	IaFbk UNFILTERED	0.0	0.0	0.0	%		V0 W4
66	bu	CURRENT LOOP	IaDmd UNFILTERED	0.0	0.0	0.0	%		V0 W4
67	bv	CURRENT LOOP	ACTUAL POS I LIM	0.0	0.0	0.0	%		V0 W4
68	bw	SEQUENCING	START (C3)	0	1	0		0: OFF 1: ON	V1 W4
69	bx	DIGITAL INPUT 4	DIGITAL INPUT C4	0	1	0		0: OFF 1: ON	V1 W4
70	by	DIGITAL INPUT 5	DIGITAL INPUT C5	0	1	0		0: OFF 1: ON	V1 W4
71	bz	DIGITAL INPUT 1	DIGIN 1 (C6)	0	1	0		0: OFF 1: ON	V1 W4
72	c0	DIGITAL INPUT 2	DIGIN 2 (C7)	0	1	0		0: OFF 1: ON	V1 W4
73	c1	DIGITAL INPUT 3	DIGIN 3 (C8)	0	1	0		0: OFF 1: ON	V1 W4
74	c2	DIGITAL OUTPUT 1	DIGOUT 1 (B5)	0	1	0		0: OFF 1: ON	V1 W4
75	c3	DIGITAL OUTPUT 2	DIGOUT 2 (B6)	0	1	0		0: OFF 1: ON	V1 W4
76	c4	DIGITAL OUTPUT 3	DIGOUT 3 (B7)	0	1	0		0: OFF 1: ON	V1 W4
77	c5	STANDSTILL	AT ZERO SPEED	0	1	0			V0 W4
78	c6	STANDSTILL	AT ZERO SETPOINT	0	1	0			V1 W4
79	c7	STANDSTILL	AT STANDSTILL	0	1	0			V1 W4
80	c8	SEQUENCING	PROGRAM STOP	0	1	0			V1 W4
81	c9	ALARMS	SPEED FBK ALARM	0	1	0		0: ENABLED 1: INHIBITED	V0 W0
82	ca	SEQUENCING	DRIVE START	0	1	0		0: OFF 1: ON	V0 W4
83	cb	SEQUENCING	CONTACTOR CLOSED	0	1	0			V0 W4

## Parameter Specification Tables C-5

Tag	Mn	MMI Block Name	MMI Parameter Name	Minimum	Maximum	Default	Units	Range	Notes	
84	cc	SEQUENCING	DRIVE ENABLE	0	1	0			V0	W4
85	cd	RAMPS	RAMP OUTPUT	0.00	0.00	0.00	%		V1	W4
86	ce	SETPOINT SUM 1	SPT SUM OUTPUT	0.00	0.00	0.00	%		V1	W4
87	cf	CURRENT LOOP	POS. I CLAMP	0.0	0.0	0.0	%		V1	W4
88	cg	CURRENT LOOP	NEG. I CLAMP	0.0	0.0	0.0	%		V1	W4
89	ch	SPEED LOOP	SPEED DEMAND	0.00	0.00	0.00	%		V0	W4
90	ci	CURRENT LOOP	BIPOLAR CLAMPS	0	1	0		0: DISABLED 1: ENABLED	V1	W0
91	cj	STOP RATES	PROG STOP I LIM	0.00	200.00	100.00	%		V0	W0
92	ck	ALARMS	ENCODER ALARM	0	1	0		0: ENABLED 1: INHIBITED	V0	W0
93	cl	CURRENT PROFILE	IMAX BRK1(SPD1)	0.0	200.0	200.0	%		V0	W1
94	cm	AUX I/O	AUX DIGOUT 1	0	1	0		0: OFF 1: ON	V0	W0
95	cn	AUX I/O	AUX DIGOUT 2	0	1	0		0: OFF 1: ON	V0	W0
96	co	AUX I/O	AUX DIGOUT 3	0	1	0		0: OFF 1: ON	V0	W0
97	cp	LINK 13	SOURCE TAG	-1276	1276	77			V0	W2
98	cq	LINK 14	SOURCE TAG	-1276	1276	122			V0	W2
99	cr	LINK 15	SOURCE TAG	-1276	1276	125			V0	W2
100	cs	DEADBAND	INPUT 1	-200.00	200.00	0.00	%		V1	W0
102	cu	LINK 20	DESTINATION TAG	0	1276	90			V0	W2
103	cv	DIGITAL INPUT 1	VALUE FOR TRUE	-300.00	300.00	0.01	%		V0	W0
104	cw	DIGITAL INPUT 1	VALUE FOR FALSE	-300.00	300.00	0.00	%		V0	W0
105	cx	LINK 21	DESTINATION TAG	0	1276	118			V0	W2
106	cy	DIGITAL INPUT 2	VALUE FOR TRUE	-300.00	300.00	0.01	%		V0	W0
107	cz	DIGITAL INPUT 2	VALUE FOR FALSE	-300.00	300.00	0.00	%		V0	W0
108	d0	LINK 22	DESTINATION TAG	0	1276	119			V0	W2
109	d1	DIGITAL INPUT 3	VALUE FOR TRUE	-300.00	300.00	0.01	%		V0	W0
110	d2	DIGITAL INPUT 3	VALUE FOR FALSE	-300.00	300.00	0.00	%		V0	W0
111	d3	ALARMS	5703 RCV ERROR	0	1	0		0: ENABLED 1: INHIBITED	V0	W0
112	d4	ALARMS	STALL TRIP	0	1	0		0: OK 1: FAILED	V1	W4

## C-6 Parameter Specification Tables

Tag	Mn	MMI Block Name	MMI Parameter Name	Minimum	Maximum	Default	Units	Range	Notes
113	d5	RAMPS	RAMPING	0	1	0			V1 W4
114	d6	SEQUENCING	SEQ STATE	0	15	0		0: SEQ INIT 1: SEQ INIT 2: SEQ HOLD 3: SEQ STANDBY 4: SEQ PRE READY 5: SEQ READY 6: SEQ AUTOTUNING 7: SEQ RUN 8: SEQ AT ZERO SPD. 9: SEQ QUENCH 10: SEQ PROGRAM STOP 11: SEQ STOP 12: SEQ DELAY STOP 13: SEQ COAST STOP 14: SEQ ERROR 15: CURRENT DECAY	V0 W4
115	d7	ALARMS	HEALTH WORD	0x0000	0xFFFF	0x0000			V1 W4
116	d8	ALARMS	HEALTH STORE	0x0000	0xFFFF	0x0000			V1 W4
118	da	RAMPS	RAMP HOLD	0	1	0		0: OFF 1: ON	V1 W0
119	db	CURRENT LOOP	I DMD. ISOLATE	0	1	0		0: DISABLED 1: ENABLED	V1 W0
120	dc	MENUS	ENTER PASSWORD	0x0000	0xFFFF	0x04D2			V0 W0
121	dd	MENUS	CHANGE PASSWORD	0x0000	0xFFFF	0x0000			V1 W0
122	de	ALARMS	HEALTH LED	0	1	0			V0 W4
125	dh	SEQUENCING	READY	0	1	0			V0 W4
126	di	MIN SPEED	MIN SPEED	0.00	100.00	0.00	%		V1 W0
128	dk	AUX I/O	ANOUT 1	-100.00	100.00	0.00	%		V0 W0
129	dl	AUX I/O	ANOUT 2	-100.00	100.00	0.00	%		V0 W0
130	dm	COMMS PORT 3	MODE	0	4	3		0: DISABLED 1: 5703 MASTER 2: 5703 SLAVE 3: EIASCII 4: EIBINARY	V0 W0
131	dn	DEADBAND	DEADBAND WIDTH	0.0	100.0	0.0	%		V0 W0
132	do	5703 IN	SETPT. RATIO	-3.0000	3.0000	0.0000			V0 W0

## Parameter Specification Tables C-7

Tag	Mn	MMI Block Name	MMI Parameter Name	Minimum	Maximum	Default	Units	Range	Notes	
133	dp	5703 IN	SETPT. SIGN	0	1	1		0: NEGATIVE 1: POSITIVE	V0	W0
134	dq	LINK 16	SOURCE TAG	-1276	1276	89			V0	W2
135	dr	LINK 45	DESTINATION TAG	0	1276	41			V0	W2
137	dt	CURRENT LOOP	DISCONTINUOUS	0.00	200.00	12.00	%		V0	W0
155	eb	DRIVE INFO	VERSION NUMBER	0x0000	0xFFFF	0x0000			V0	W4
158	ee	COMMS PORT 2	ERROR REPORT	0x0000	0xFFFF	0x00C0			V0	W0
161	eh	SEQUENCING	AUX START	0	1	1		0: OFF 1: ON	V0	W0
162	ei	CONFIGURE DRIVE	EMULATE 590P	0x0000	0xFFFF	0x0001			V1	W2
168	eo	SEQUENCING	AUX ENABLE	0	1	1		0: OFF 1: ON	V0	W0
169	ep	FIELD CONTROL	FIELD ENABLED	0	1	0		0: DISABLED 1: ENABLED	V0	W4
170	eq	FIELD CONTROL	FIELD ENABLE	0	1	1		0: DISABLED 1: ENABLED	V0	W1
171	er	FIELD CONTROL	SETPOINT	0.00	100.00	100.00	%		V1	W0
172	es	FIELD CONTROL	INT. GAIN	0.00	100.00	1.28			V0	W0
173	et	FIELD CONTROL	PROP. GAIN	0.00	100.00	0.10			V0	W0
174	eu	FIELD CONTROL	FLD. WEAK ENABLE	0	2	0		0: DISABLED 1: STANDARD 2: ADVANCED	V0	W1
175	ev	FIELD CONTROL	EMF LEAD	0.10	50.00	2.00			V0	W0
176	ew	FIELD CONTROL	EMF LAG	0.00	200.00	40.00			V0	W0
177	ex	FIELD CONTROL	EMF GAIN	0.00	100.00	0.30			V0	W0
178	ey	FIELD CONTROL	MAX VOLTS	0.00	100.00	100.00	%		V0	W0
179	ez	FIELD CONTROL	MIN FLD.CURRENT	0.00	100.00	90.00	%		V0	W1
180	f0	ALARMS	SPDFBK ALM LEVEL	0.0	100.0	50.0	%		V1	W0
181	f1	FEEDBACKS	UNFIL.FIELD FBK	0.00	0.00	0.00	%		V0	W4
182	f2	CALIBRATION	FIELD I CAL.	0.9800	1.1000	1.0000			V0	W0
183	f3	FIELD CONTROL	FIELD DEMAND	0.00	0.00	0.00	%		V1	W4
184	f4	FIELD CONTROL	FLD.FIRING ANGLE	0.00	0.00	0.00	DEG		V1	W4
185	f5	FIELD CONTROL	FLD.QUENCH DELAY	0.0	600.0	0.0	s		V1	W0
186	f6	FIELD CONTROL	FLD. QUENCH MODE	0	1	0		0: QUENCH 1: STANDBY	V1	W0

## C-8 Parameter Specification Tables

Tag	Mn	MMI Block Name	MMI Parameter Name	Minimum	Maximum	Default	Units	Range	Notes
187	f7	5703 IN	RAW INPUT	0.00	0.00	0.00	%		V0 W4
189	f9	5703 IN	SCALED INPUT	0.00	0.00	0.00	%		V0 W4
191	fb	FIELD CONTROL	BEMF FBK LEAD	20	5000	100			V0 W0
192	fc	FIELD CONTROL	BEMF FBK LAG	20	5000	100			V0 W0
195	ff	DIGITAL OUTPUT 1	THRESHOLD (>)	-300.00	300.00	0.00	%		V0 W0
196	fg	DIGITAL OUTPUT 2	THRESHOLD (>)	-300.00	300.00	0.00	%		V0 W0
197	fh	DIGITAL OUTPUT 3	THRESHOLD (>)	-300.00	300.00	0.00	%		V0 W0
198	fi	COMMS PORT 3	BAUD RATE	0	9	5		0: 300 1: 600 2: 1200 3: 2400 4: 4800 5: 9600 6: 19200 7: 38400 8: 57600 9: 115200	V0 W0
201	fl	CURRENT LOOP	REGEN ENABLE	0	1	1		0: 2Q (NON-REGEN) 1: 4Q (REGEN)	V0 W1
202	fm	SPEED LOOP	INT. DEFEAT	0	1	0		0: OFF 1: ON	V1 W0
203	fn	INVERSE TIME	INVERSE TIME O/P	0.00	0.00	0.00	%		V1 W4
206	fq	ENCODER 1	ENCODER	0	0	0	RPM		V0 W4
207	fr	FEEDBACKS	SPEED FEEDBACK	0.00	0.00	0.00	%		V0 W4
208	fs	SETPOINT SUM 1	RATIO 0	-3.0000	3.0000	1.0000			V0 W0
209	ft	FIELD CONTROL	FLD.CTRL MODE	0	1	0		0: VOLTAGE CONTROL 1: CURRENT CONTROL	V0 W1
210	fu	FIELD CONTROL	FLD.VOLTS RATIO	0.0	100.0	90.0	%		V0 W0
212	fw	JOG/SLACK	OPERATING MODE	0	7	0		0: STOP 1: STOP 2: JOG SP. 1 3: JOG SP. 2 4: RUN 5: TAKE UP SP. 1 6: TAKE UP SP. 2 7: CRAWL	V1 W4
216	g0	STOP RATES	PROG STOP LIMIT	0.0	600.0	60.0	s		V1 W0

## Parameter Specification Tables C-9

Tag	Mn	MMI Block Name	MMI Parameter Name	Minimum	Maximum	Default	Units	Range	Notes	
217	g1	STOP RATES	STOP LIMIT	0.0	600.0	60.0	s		V1	W0
218	g2	JOG/SLACK	JOG SPEED 1	-100.00	100.00	5.00	%		V0	W0
219	g3	JOG/SLACK	JOG SPEED 2	-100.00	100.00	-5.00	%		V0	W0
224	g8	ALARMS	STALL TRIP DELAY	0.1	600.0	30.0	s		V1	W0
225	g9	JOG/SLACK	CRAWL SPEED	-100.00	100.00	10.00	%		V0	W0
227	gb	SEQUENCING	AUX JOG	0	1	1		0: OFF 1: ON	V0	W0
228	gc	JOG/SLACK	MODE	0	1	0			V0	W0
230	ge	ANALOG INPUT 1	CALIBRATION	-3.0000	3.0000	1.0000			V0	W0
231	gf	ANALOG INPUT 1	MAX VALUE	-300.00	300.00	100.00	%		V0	W0
232	gg	ANALOG INPUT 1	MIN VALUE	-300.00	300.00	-100.00	%		V0	W0
233	gh	ANALOG INPUT 2	CALIBRATION	-3.0000	3.0000	1.0000			V0	W0
234	gi	ANALOG INPUT 2	MAX VALUE	-300.00	300.00	100.00	%		V0	W0
235	gj	ANALOG INPUT 2	MIN VALUE	-300.00	300.00	-100.00	%		V0	W0
236	gk	ANALOG INPUT 3	CALIBRATION	-3.0000	3.0000	1.0000			V0	W0
237	gl	ANALOG INPUT 3	MAX VALUE	-300.00	300.00	100.00	%		V0	W0
238	gm	ANALOG INPUT 3	MIN VALUE	-300.00	300.00	-100.00	%		V0	W0
239	gn	ANALOG INPUT 4	CALIBRATION	-3.0000	3.0000	1.0000			V0	W0
240	go	ANALOG INPUT 4	MAX VALUE	-300.00	300.00	200.00	%		V0	W0
241	gp	ANALOG INPUT 4	MIN VALUE	-300.00	300.00	-200.00	%		V0	W0
242	gq	ANALOG INPUT 5	CALIBRATION	-3.0000	3.0000	1.0000			V0	W0
243	gr	ANALOG INPUT 5	MAX VALUE	-300.00	300.00	200.00	%		V0	W0
244	gs	ANALOG INPUT 5	MIN VALUE	-300.00	300.00	-200.00	%		V0	W0
245	gt	ANALOG OUTPUT 1	% TO GET 10V	-300.00	300.00	100.00	%		V0	W0
246	gu	LINK 23	DESTINATION TAG	0	1276	100			V0	W2
247	gv	LINK 26	DESTINATION TAG	0	1276	301			V0	W2
248	gw	ANALOG OUTPUT 2	% TO GET 10V	-300.00	300.00	100.00	%		V0	W0
249	gx	LINK 24	DESTINATION TAG	0	1276	5			V0	W2
250	gy	LINK 25	DESTINATION TAG	0	1276	48			V0	W2
251	gz	LINK 17	SOURCE TAG	-1276	1276	62			V0	W2
252	h0	LINK 18	SOURCE TAG	-1276	1276	63			V0	W2
253	h1	JOG/SLACK	TAKE UP 1	-100.00	100.00	5.00	%		V0	W0
254	h2	JOG/SLACK	TAKE UP 2	-100.00	100.00	-5.00	%		V0	W0
255	h3	RAISE/LOWER	RESET VALUE	-300.00	300.00	0.00	%		V0	W0



## C-10 Parameter Specification Tables

Tag	Mn	MMI Block Name	MMI Parameter Name	Minimum	Maximum	Default	Units	Range	Notes
256	h4	RAISE/LOWER	INCREASE RATE	0.1	600.0	10.0	s		V0 W0
257	h5	RAISE/LOWER	DECREASE RATE	0.1	600.0	10.0	s		V0 W0
258	h6	RAISE/LOWER	MIN VALUE	-300.00	300.00	-100.00	%		V0 W0
259	h7	RAISE/LOWER	MAX VALUE	-300.00	300.00	100.00	%		V0 W0
260	h8	LINK 27	RAISE/LOWER DEST	0	1276	0			V0 W2
261	h9	RAISE/LOWER	RAISE INPUT	0	1	0			V0 W0
262	ha	RAISE/LOWER	LOWER INPUT	0	1	0			V0 W0
263	hb	ALARMS	STALL THRESHOLD	0.00	200.00	95.00	%		V1 W0
264	hc	RAISE/LOWER	RAISE/LOWER O/P	0.00	0.00	0.00	%		V0 W4
266	he	RAMPS	% S-RAMP	0.00	100.00	2.50	%		V1 W0
268	hg	SPEED LOOP	MODE	0	3	0		0: DISABLED 1: SPD FBK DEP 2: SPD ERR DEP 3: CUR DMD DEP	V0 W0
269	hh	SPEED LOOP	SPD BRK1 (LOW)	0.00	100.00	1.00	%		V0 W0
270	hi	SPEED LOOP	SPD BRK2 (HIGH)	0.00	100.00	5.00	%		V0 W0
271	hj	SPEED LOOP	PROP. GAIN	0.00	200.00	5.00			V0 W0
272	hk	SPEED LOOP	INT.TIME.CONST	0.001	30.000	0.500	s		V0 W0
274	hm	SPEED LOOP	I GAIN IN RAMP	0.0000	2.0000	1.0000			V0 W0
284	hw	SPEED LOOP	ZERO SPD. LEVEL	0.00	200.00	0.50	%		V0 W0
285	hx	SPEED LOOP	ZERO IAD LEVEL	0.00	200.00	1.50	%		V0 W0
286	hy	RAMPS	RAMPING THRESH.	0.00	100.00	0.50	%		V1 W0
287	hz	RAMPS	AUTO RESET	0	1	1		0: DISABLED 1: ENABLED	V1 W0
288	i0	RAMPS	EXTERNAL RESET	0	1	0		0: DISABLED 1: ENABLED	V1 W0
289	i1	SPEED LOOP	SETPOINT 1	-105.00	105.00	0.00	%		V0 W0
290	i2	SPEED LOOP	SETPOINT 2 (A3)	0.00	0.00	0.00	%		V0 W4
291	i3	SPEED LOOP	SETPOINT 3	-105.00	105.00	0.00	%		V0 W0
292	i4	SETPOINT SUM 1	SIGN 0	0	1	1		0: NEGATIVE 1: POSITIVE	V1 W0
293	i5	LINK 28	RAMP O/P DEST	0	1276	291			V0 W2
294	i6	LINK 29	SPT SUM 1 DEST	0	1276	289			V0 W2
297	i9	SPEED LOOP	SPEED ERROR	0.00	0.00	0.00	%		V0 W4
298	ia	FEEDBACKS	CURRENT FEEDBACK	0.00	0.00	0.00	%		V0 W4

## Parameter Specification Tables C-11

Tag	Mn	MMI Block Name	MMI Parameter Name	Minimum	Maximum	Default	Units	Range	Notes	
299	ib	CURRENT LOOP	CURRENT DEMAND	0.00	0.00	0.00	%		V0	W4
300	ic	FIELD CONTROL	FIELD I FBK.	0.00	0.00	0.00	%		V0	W4
301	id	CURRENT LOOP	POS. I CLAMP IN	-200.00	200.00	200.00	%		V0	W0
302	ie	STOP RATES	CONTACTOR DELAY	0.1	600.0	1.0	s		V1	W0
304	ig	MENUS	LANGUAGE	0	1	0		0: ENGLISH 1: ENGLISH	V1	W1
305	ih	ALARMS	TRIP RESET	0	1	1			V1	W0
306	ii	LINK 19	SOURCE TAG	-1276	1276	89			V0	W2
307	ij	RAISE/LOWER	EXTERNAL RESET	0	1	0			V1	W0
308	ik	FEEDBACKS	TACH INPUT	0.0	0.0	0.0	%		V0	W4
309	il	SETPOINT SUM 1	INPUT 0	-300.00	300.00	0.00	%		V1	W0
312	io	PNO CONFIG	PNO 112	-1276	1276	0			V0	W0
313	ip	PNO CONFIG	PNO 113	-1276	1276	0			V0	W0
314	iq	PNO CONFIG	PNO 114	-1276	1276	0			V0	W0
315	ir	PNO CONFIG	PNO 115	-1276	1276	0			V0	W0
316	is	PNO CONFIG	PNO 116	-1276	1276	0			V0	W0
317	it	PNO CONFIG	PNO 117	-1276	1276	0			V0	W0
318	iu	PNO CONFIG	PNO 118	-1276	1276	0			V0	W0
319	iv	PNO CONFIG	PNO 119	-1276	1276	0			V0	W0
320	iw	PNO CONFIG	PNO 120	-1276	1276	379			V0	W0
321	ix	PNO CONFIG	PNO 121	-1276	1276	380			V0	W0
322	iy	PNO CONFIG	PNO 122	-1276	1276	381			V0	W0
323	iz	PNO CONFIG	PNO 123	-1276	1276	382			V0	W0
324	j0	PNO CONFIG	PNO 124	-1276	1276	383			V0	W0
325	j1	PNO CONFIG	PNO 125	-1276	1276	384			V0	W0
326	j2	PNO CONFIG	PNO 126	-1276	1276	385			V0	W0
327	j3	PNO CONFIG	PNO 127	-1276	1276	0			V0	W0
328	j4	COMMS PORT 3	ESP SUP.(ASCII)	0	1	1			V0	W0
329	j5	COMMS PORT 3	GROUP ID (GID)	0	7	0			V0	W0
330	j6	COMMS PORT 3	UNIT ID (UID)	0	255	0			V0	W0
331	j7	COMMS PORT 3	CHANGEBAND (BIN)	0.00	100.00	0.00	%		V0	W0
332	j8	COMMS PORT 3	ERROR REPORT	0x0000	0xFFFF	0x00C0			V0	W0
333	j9	COMMS PORT 3	PNO.7	0x0000	0xFFFF	0xFFFF			V0	W0
337	jd	ALARMS	THERMISTOR STATE	0	1	0			V0	W4

## C-12 Parameter Specification Tables

Tag	Mn	MMI Block Name	MMI Parameter Name	Minimum	Maximum	Default	Units	Range	Notes
339	jf	miniLINK	VALUE 1	-300.00	300.00	0.00	%		V1 W0
340	jg	miniLINK	VALUE 2	-300.00	300.00	0.00	%		V1 W0
341	jh	miniLINK	VALUE 3	-300.00	300.00	0.00	%		V1 W0
342	ji	miniLINK	VALUE 4	-300.00	300.00	0.00	%		V1 W0
343	jj	miniLINK	VALUE 5	-300.00	300.00	0.00	%		V1 W0
344	jk	miniLINK	VALUE 6	-300.00	300.00	0.00	%		V1 W0
345	jl	miniLINK	VALUE 7	-300.00	300.00	0.00	%		V1 W0
346	jm	miniLINK	LOGIC 1	0	1	0		0: OFF 1: ON	V1 W0
347	jn	miniLINK	LOGIC 2	0	1	0		0: OFF 1: ON	V1 W0
348	jo	miniLINK	LOGIC 3	0	1	0		0: OFF 1: ON	V1 W0
349	jp	miniLINK	LOGIC 4	0	1	0		0: OFF 1: ON	V1 W0
350	jq	miniLINK	LOGIC 5	0	1	0		0: OFF 1: ON	V1 W0
351	jr	miniLINK	LOGIC 6	0	1	0		0: OFF 1: ON	V1 W0
352	js	miniLINK	LOGIC 7	0	1	0		0: OFF 1: ON	V1 W0
353	jt	miniLINK	LOGIC 8	0	1	0		0: OFF 1: ON	V1 W0
355	jv	JOG/SLACK	RAMP RATE	0.1	600.0	1.0	s		V0 W0
357	jx	SPEED LOOP	MAX DEMAND	0.00	105.00	105.00	%		V0 W0
358	jy	SPEED LOOP	MIN DEMAND	-105.00	105.00	-105.00	%		V0 W0
359	jz	DIGITAL OUTPUT	1 INVERTED	0	1	0			V0 W0
360	k0	DIGITAL OUTPUT	2 INVERTED	0	1	0			V0 W0
361	k1	DIGITAL OUTPUT	3 INVERTED	0	1	0			V0 W0
362	k2	ANALOG OUTPUT	1 MODULUS	0	1	0			V0 W0
363	k3	ANALOG OUTPUT	2 MODULUS	0	1	0			V0 W0
364	k4	LINK	1 SOURCE TAG	-1276	1276	0			V0 W2
365	k5	LINK	1 DESTINATION TAG	0	1276	0			V0 W2
366	k6	LINK	2 SOURCE TAG	-1276	1276	0			V0 W2
367	k7	LINK	2 DESTINATION TAG	0	1276	0			V0 W2

## Parameter Specification Tables C-13

Tag	Mn	MMI Block Name	MMI Parameter Name	Minimum	Maximum	Default	Units	Range	Notes
368	k8	LINK 3	SOURCE TAG	-1276	1276	0			V0 W2
369	k9	LINK 3	DESTINATION TAG	0	1276	0			V0 W2
370	ka	LINK 4	SOURCE TAG	-1276	1276	0			V0 W2
371	kb	LINK 4	DESTINATION TAG	0	1276	0			V0 W2
374	ke	SEQUENCING	SYSTEM RESET	0	1	0			V0 W4
375	kf	SETPOINT SUM 1	LIMIT	0.00	200.00	105.00	%		V0 W0
376	kg	SEQUENCING	DRIVE RUNNING	0	1	0			V0 W4
379	kj	miniLINK	VALUE 8	-300.00	300.00	0.00	%		V1 W0
380	kk	miniLINK	VALUE 9	-300.00	300.00	0.00	%		V1 W0
381	kl	miniLINK	VALUE 10	-300.00	300.00	0.00	%		V1 W0
382	km	miniLINK	VALUE 11	-300.00	300.00	0.00	%		V1 W0
383	kn	miniLINK	VALUE 12	-300.00	300.00	0.00	%		V1 W0
384	ko	miniLINK	VALUE 13	-300.00	300.00	0.00	%		V1 W0
385	kp	miniLINK	VALUE 14	-300.00	300.00	0.00	%		V1 W0
390	ku	LINK 11	SOURCE TAG	-1276	1276	0			V0 W2
391	kv	LINK 43	DESTINATION TAG	0	1276	0			V0 W2
392	kw	ADVANCED 1	ADVANCED	0	1	0		0: OFF 1: ON	V0 W0
393	kx	ADVANCED 1	MODE	0	6	0		0: SWITCH 1: INVERT 2: AND 3: OR 4: SIGN CHANGER 5: MODULUS 6: COMPARATOR	V0 W0
394	ky	LINK 41	AUX.SOURCE	-1276	1276	0			V0 W2
395	kz	LINK 12	SOURCE TAG	-1276	1276	0			V0 W2
396	l0	LINK 44	DESTINATION TAG	0	1276	0			V0 W2
397	l1	ADVANCED 2	ADVANCED	0	1	0		0: OFF 1: ON	V0 W0
398	l2	ADVANCED 2	MODE	0	6	0		See Tag 393	V0 W0
399	l3	LINK 42	AUX.SOURCE	-1276	1276	0			V0 W2
400	l4	LINK 30	PID O/P DEST	0	1276	0			V0 W2
401	l5	PID	DERIVATIVE TC	0.000	10.000	0.000	s		V1 W0
402	l6	PID	INT.TIME.CONST	0.01	100.00	5.00	s		V1 W0

## C-14 Parameter Specification Tables

Tag	Mn	MMI Block Name	MMI Parameter Name	Minimum	Maximum	Default	Units	Range	Notes
403	l7	PID	FILTER T.C.	0.000	10.000	0.100	s		V1 W0
404	l8	PROFILED GAIN	PROP. GAIN	0.0	100.0	1.0			V1 W0
405	l9	PID	POSITIVE LIMIT	0.00	105.00	100.00	%		V1 W0
406	la	PID	NEGATIVE LIMIT	-105.00	0.00	-100.00	%		V1 W0
407	lb	PID	O/P SCALER(TRIM)	-3.0000	3.0000	0.2000			V1 W0
408	lc	PID	ENABLE	0	1	1		0: DISABLED 1: ENABLED	V1 W0
409	ld	PID	INT. DEFEAT	0	1	0		0: OFF 1: ON	V1 W0
410	le	PID	INPUT 1	-300.00	300.00	0.00	%		V1 W0
411	lf	PID	INPUT 2	-300.00	300.00	0.00	%		V1 W0
412	lg	PID	RATIO 1	-3.0000	3.0000	1.0000			V1 W0
413	lh	PID	RATIO 2	-3.0000	3.0000	1.0000			V1 W0
414	li	PID	DIVIDER 2	-3.0000	3.0000	1.0000			V1 W0
415	lj	PID	PID ERROR	0.00	0.00	0.00	%		V1 W4
416	lk	PID	PID CLAMPED	0	1	0			V1 W4
417	ll	PID	PID OUTPUT	0.00	0.00	0.00	%		V1 W4
418	lm	PID	DIVIDER 1	-3.0000	3.0000	1.0000			V1 W0
419	ln	SETPOINT SUM 1	DIVIDER 1	-3.0000	3.0000	1.0000			V1 W0
420	lo	SETPOINT SUM 1	DIVIDER 0	-3.0000	3.0000	1.0000			V0 W0
421	lp	CURRENT LOOP	MAIN CURR. LIMIT	0.00	200.00	110.00	%		V0 W0
422	lq	RAMPS	RESET VALUE	-300.00	300.00	0.00	%		V1 W0
423	lr	SETPOINT SUM 1	INPUT 2	-300.00	300.00	0.00	%		V1 W0
424	ls	DIAMETER CALC.	LINE SPEED	-105.00	105.00	0.00	%		V1 W0
425	lt	DIAMETER CALC.	MIN DIAMETER	0.00	100.00	10.00	%		V1 W0
426	lu	DIAMETER CALC.	MIN SPEED	0.00	100.00	5.00	%		V1 W0
427	lv	DIAMETER CALC.	DIAMETER	0.00	0.00	0.00	%		V1 W4
428	lw	DIAMETER CALC.	MOD OF LINE SPD	0.00	0.00	0.00	%		V0 W4
429	lx	DIAMETER CALC.	MOD OF REEL SPD	0.00	0.00	0.00	%		V0 W4
430	ly	DIAMETER CALC.	UNFILT DIAMETER	0.00	0.00	0.00	%		V0 W4
431	lz	LINK 31	DIAMETER	0	1276	0			V0 W2
432	m0	TORQUE CALC.	TORQUE DEMAND	-200.00	200.00	0.00	%		V1 W0
433	m1	TORQUE CALC.	TENSION ENABLE	0	1	1		0: DISABLED 1: ENABLED	V1 W0

## Parameter Specification Tables C-15

Tag	Mn	MMI Block Name	MMI Parameter Name	Minimum	Maximum	Default	Units	Range	Notes
434	m2	TORQUE CALC.	OVER WIND	0	1	1		0: DISABLED 1: ENABLED	V1 W0
435	m3	LINK 32	POS. I CLAMP	0	1276	0			V0 W2
436	m4	LINK 33	NEG. I CLAMP	0	1276	0			V0 W2
437	m5	DIAMETER CALC.	REEL SPEED	-105.00	105.00	0.00	%		V1 W0
438	m6	DIAMETER CALC.	TAPER	-100.00	100.00	0.00	%		V1 W0
439	m7	DIAMETER CALC.	TENSION SPT.	0.00	100.00	0.00	%		V1 W0
440	m8	DIAMETER CALC.	TENSION TRIM	-100.00	100.00	0.00	%		V1 W0
441	m9	DIAMETER CALC.	TOT.TENS.DEMAND	0.00	0.00	0.00	%		V1 W4
442	ma	LINK 34	TAPER	0	1276	0			V0 W2
443	mb	SETPOINT SUM 2	INPUT 1	-300.00	300.00	0.00	%		V1 W0
444	mc	SETPOINT SUM 2	INPUT 0	-300.00	300.00	0.00	%		V1 W0
445	md	SETPOINT SUM 2	INPUT 2	-300.00	300.00	0.00	%		V1 W0
446	me	SETPOINT SUM 2	RATIO 1	-3.0000	3.0000	1.0000			V0 W0
447	mf	SETPOINT SUM 2	RATIO 0	-3.0000	3.0000	1.0000			V0 W0
448	mg	SETPOINT SUM 2	DIVIDER 0	-3.0000	3.0000	1.0000			V0 W0
449	mh	SETPOINT SUM 2	LIMIT	0.00	200.00	105.00	%		V0 W0
450	mi	LINK 35	SETPOINT SUM 2	0	1276	0			V0 W2
451	mj	SETPOINT SUM 2	SPT SUM OUTPUT	0.00	0.00	0.00	%		V1 W4
452	mk	DIAMETER CALC.	TAPERED DEMAND	0.00	0.00	0.00	%		V1 W4
453	ml	DIAMETER CALC.	RAMP RATE	0.1	600.0	5.0	s		V1 W0
454	mm	LINK 5	SOURCE TAG	-1276	1276	0			V0 W2
455	mn	LINK 5	DESTINATION TAG	0	1276	0			V0 W2
456	mo	LINK 6	SOURCE TAG	-1276	1276	0			V0 W2
457	mp	LINK 6	DESTINATION TAG	0	1276	0			V0 W2
458	mq	LINK 7	SOURCE TAG	-1276	1276	0			V0 W2
459	mr	LINK 7	DESTINATION TAG	0	1276	0			V0 W2
460	ms	LINK 8	SOURCE TAG	-1276	1276	0			V0 W2
461	mt	LINK 8	DESTINATION TAG	0	1276	0			V0 W2
462	mu	DIAMETER CALC.	RESET VALUE	0.00	100.00	10.00	%		V1 W0
463	mv	DIAMETER CALC.	EXTERNAL RESET	0	1	0		0: DISABLED 1: ENABLED	V1 W0
464	mw	ANALOG OUTPUT 1	OFFSET	-100.00	100.00	0.00	%		V0 W0
465	mx	ANALOG OUTPUT 2	OFFSET	-100.00	100.00	0.00	%		V0 W0

## C-16 Parameter Specification Tables

Tag	Mn	MMI Block Name	MMI Parameter Name	Minimum	Maximum	Default	Units	Range	Notes
466	my	SETPOINT SUM 2	DIVIDER 1	-3.0000	3.0000	1.0000			V1 W0
467	mz	LINK 9	SOURCE TAG	-1276	1276	0			V0 W2
468	n0	LINK 9	DESTINATION TAG	0	1276	0			V0 W2
469	n1	LINK 10	SOURCE TAG	-1276	1276	0			V0 W2
470	n2	LINK 10	DESTINATION TAG	0	1276	0			V0 W2
472	n4	ALARMS	SPEED FBK STATE	0	1	0			V0 W4
473	n5	PROFILED GAIN	MODE	0	4	0			V1 W0
474	n6	PROFILED GAIN	MIN PROFILE GAIN	0.00	100.00	20.00	%		V1 W0
475	n7	PROFILED GAIN	PROFILED GAIN	0.0	0.0	0.0			V1 W4
478	na	LINK 36	TENS+COMP CALC.	0	1276	0			V0 W2
479	nb	DIAMETER CALC.	FIX.INERTIA COMP	-300.00	300.00	0.00	%		V1 W0
480	nc	DIAMETER CALC.	VAR.INERTIA COMP	-300.00	300.00	0.00	%		V1 W0
481	nd	DIAMETER CALC.	ROLL WIDTH/MASS	0.00	100.00	100.00	%		V1 W0
482	ne	DIAMETER CALC.	FILTER T.C.	0	20000	10			V1 W0
483	nf	DIAMETER CALC.	RATE CAL	-100.00	100.00	10.00			V1 W0
484	ng	DIAMETER CALC.	NORMALISED dv/dt	-300.00	300.00	0.00	%		V1 W0
485	nh	DIAMETER CALC.	INERTIA COMP O/P	0.00	0.00	0.00	%		V1 W4
486	ni	DIAMETER CALC.	TENSION SCALER	-3.0000	3.0000	1.0000			V1 W0
487	nj	DIAMETER CALC.	STATIC COMP	-300.00	300.00	0.00	%		V0 W0
488	nk	DIAMETER CALC.	DYNAMIC COMP	-300.00	300.00	0.00	%		V0 W0
489	nl	DIAMETER CALC.	REWIND	0	1	1		0: DISABLED 1: ENABLED	V0 W0
491	nn	SETPOINT SUM 2	STPT SUM 2 OUT 0	0.00	0.00	0.00	%		V0 W4
492	no	SETPOINT SUM 2	STPT SUM 2 OUT 1	0.00	0.00	0.00	%		V0 W4
493	np	ANALOG INPUT 2	OUTPUT	0.00	0.00	0.00	%		V0 W4
494	nq	LINK 37	DESTINATION TAG	0	1276	496			V0 W2
495	nr	LINK 38	DESTINATION TAG	0	1276	497			V0 W2
496	ns	SEQUENCING	JOG/SLACK	0	1	0		0: OFF 1: ON	V0 W0
497	nt	SEQUENCING	ENABLE	0	1	0		0: OFF 1: ON	V0 W0
498	nu	DIAMETER CALC.	LINE SPEED SPT	-105.00	105.00	0.00	%		V0 W0

## Parameter Specification Tables C-17

Tag	Mn	MMI Block Name	MMI Parameter Name	Minimum	Maximum	Default	Units	Range	Notes
500	nw	TEC OPTION	TEC OPTION TYPE	0	15	0		0: NONE 1: RS485 2: PROFIBUS DP 3: LINK 4: DEVICE NET 5: CAN OPEN 6: LONWORKS 7: CONTROLNET 8: MODBUS PLUS 9: ETHERNET 10: TYPE 10 11: TYPE 11 12: TYPE 12 13: TYPE 13 14: TYPE 14 15: TYPE 15	V0 W0
501	nx	TEC OPTION	TEC OPTION IN 1	-32768	32767	0			V0 W0
502	ny	TEC OPTION	TEC OPTION IN 2	-32768	32767	0			V0 W0
503	nz	TEC OPTION	TEC OPTION IN 3	-32768	32767	0			V0 W0
504	o0	TEC OPTION	TEC OPTION IN 4	-32768	32767	0			V0 W0
505	o1	TEC OPTION	TEC OPTION IN 5	-32768	32767	0			V0 W0
506	o2	TEC OPTION	TEC OPTION FAULT	0	5	0		0: NONE 1: PARAMETER 2: TYPE MISMATCH 3: SELF TEST 4: HARDWARE 5: MISSING	V0 W4
507	o3	TEC OPTION	TEC OPTION VER	0x0000	0xFFFF	0x0000			V0 W4
508	o4	TEC OPTION	TEC OPTION OUT 1	0	0	0			V0 W4
509	o5	TEC OPTION	TEC OPTION OUT 2	0	0	0			V0 W4
510	o6	DRIVE INFO	PRODUCT CODE	0	104	3		0: INVALID 1: DC 4Q 15A 2: DC 2Q 15A 3: DC 4Q 35A 4: DC 2Q 35A 5: DC 4Q 40A 6: DC 2Q 40A 7: DC 4Q 55A 8: DC 2Q 55A	V0 W3



# C-18 Parameter Specification Tables

Tag	Mn	MMI Block Name	MMI Parameter Name	Minimum	Maximum	Default	Units	Range	Notes
								9: DC 4Q 70A 10: DC 2Q 70A 11: DC 4Q 90A 12: DC 2Q 90A 13: DC 4Q 110A 14: DC 2Q 110A 15: DC 4Q 125A 16: DC 2Q 125A 17: DC 4Q 162A 18: DC 2Q 162A 19: DC 4Q 165A 20: DC 2Q 165A 21: DC 4Q 35A D 22: DC 2Q 35A D 23: DC 4Q 70A D 24: DC 2Q 70A D 25: DC 4Q 110A D 26: DC 2Q 110A D 27: DC 4Q 150A D 28: DC 2Q 150A D 29: DC 4Q 180A D 30: DC 2Q 180A D 31: DC 4Q 270A D 32: DC 2Q 270A D 33: DC 4Q 128* 20* D 34: DC 2Q 128* 20* D 35: DC 4Q 1024* 20*D 36: DC 2Q 1024* 20*D 37: DC 4Q 1024* 26*D 38: DC 2Q 1024* 26*D 39: DC 4Q 360A D 40: DC 2Q 360A D 41: DC 4Q 450A D 42: DC 2Q 450A D 43: DC 4Q 720A D 44: DC 2Q 720A D 45: DC 4Q 800A D 46: DC 2Q 800A D 47: DC 4Q 1024* 30*D 48: DC 2Q 1024* 30*D 49: DC 4Q 1200A 20 D	

## Parameter Specification Tables C-19

Tag	Mn	MMI Block Name	MMI Parameter Name	Minimum	Maximum	Default	Units	Range	Notes
								50: DC 2Q 1200A 20 D	
								51: DC 4Q 1700A 20 D	
								52: DC 2Q 1700A 20 D	
								53: DC 4Q 2200A 20 D	
								54: DC 2Q 2200A 20 D	
								55: DC 4Q 2700A 20 D	
								56: DC 2Q 2700A 20 D	
								57: DC 4Q 1200A 40 D	
								58: DC 2Q 1200A 40 D	
								59: DC 4Q 1700A 40 D	
								60: DC 2Q 1700A 40 D	
								61: DC 4Q 2200A 40 D	
								62: DC 2Q 2200A 40 D	
								63: DC 4Q 2700A 40 D	
								64: DC 2Q 2700A 40 D	
								65: DC 4Q 1200A 60 D	
								66: DC 2Q 1200A 60 D	
								67: DC 4Q 1700A 60 D	
								68: DC 2Q 1700A 60 D	
								69: DC 4Q 2200A 60 D	
								70: DC 2Q 2200A 60 D	
								71: DC 4Q 2700A 60 D	
								72: DC 2Q 2700A 60 D	
								73: DC 4Q 1200A 80 D	
								74: DC 2Q 1200A 80 D	
								75: DC 4Q 1700A 80 D	
								76: DC 2Q 1700A 80 D	
								77: DC 4Q 2200A 80 D	
								78: DC 2Q 2200A 80 D	
								79: DC 4Q 2700A 80 D	
								80: DC 2Q 2700A 80 D	
								81: DC RETRO 4Q 128A	
								82: DC RETRO 2Q 128A	
								83: DC 2Q 40A	
								84: DC 4Q 40A	
								85: DC 4Q 725A	
								86: DC 2Q 725A	
								87: DC 4Q 830A	
								88: DC 2Q 830A	
								89: DC 4Q 1580A	
								90: DC 2Q 1580A	

## C-20 Parameter Specification Tables

Tag	Mn	MMI Block Name	MMI Parameter Name	Minimum	Maximum	Default	Units	Range	Notes	
								91: DC 4Q 380A 92: DC 2Q 380A 93: DC 4Q 500A 94: DC 2Q 500A 95: DC 4Q 725A 40*D 96: DC 2Q 725A 40*D 97: DC 4Q 830A 40*D 98: DC 2Q 830A 40*D 99: DC 4Q 1580A 40*D 100: DC 2Q 1580A 40*D 101: DC 4Q 380A 40*D 102: DC 2Q 380A 40*D 103: DC 4Q 500A 40*D 104: DC 2Q 500A 40*D		
511	o7	OP-STATION	LOCAL KEY ENABLE	0	1	1			V0	W0
512	o8	OP-STATION	SETPOINT	0.00	100.00	0.00	%		V0	W0
513	o9	OP-STATION	JOG SETPOINT	0.00	100.00	5.00	%		V0	W0
514	oa	OP-STATION	RAMP ACCEL TIME	0.1	600.0	10.0	s		V0	W0
515	ob	OP-STATION	RAMP DECEL TIME	0.1	600.0	10.0	s		V0	W0
516	oc	OP-STATION	INITIAL DIR	0	1	1		0: REVERSE 1: FORWARD	V0	W0
517	od	OP-STATION	INITIAL MODE	0	1	0		0: REMOTE 1: LOCAL	V0	W0
518	oe	OP-STATION	INITIAL VIEW	0	1	0		0: LOCAL 1: PROGRAM	V0	W0
519	of	OP-STATION	INITIAL SETPOINT	0.00	100.00	0.00	%		V0	W0
520	og	OP-STATION	INITIAL JOG	0.00	100.00	5.00	%		V0	W0
521	oh	CONFIGURE DRIVE	NOM MOTOR VOLTS	100	875	100	V		V0	W2
523	oj	CONFIGURE DRIVE	ARMATURE CURRENT	1.0	35.0	1.0	A		V0	W2
524	ok	CONFIGURE DRIVE	FIELD CURRENT	0.2	4.0	0.2	A		V0	W2
525	ol	SEQUENCING	COAST STOP	0	1	0			V0	W4
527	on	CURRENT LOOP	MASTER BRIDGE	0	1	0			V0	W4
528	oo	ALARMS	LAST ALARM	0x0000	0xFFFF	0x0000			V0	W4
535	ov	SEQUENCING	REM.SEQ.ENABLE	0	1	0			V0	W1
536	ow	SEQUENCING	REM.SEQUENCE	0x0000	0xFFFF	0x8000			V1	W0
537	ox	SEQUENCING	SEQ STATUS	0x0000	0xFFFF	0x0000			V0	W4

## Parameter Specification Tables C-21

Tag	Mn	MMI Block Name	MMI Parameter Name	Minimum	Maximum	Default	Units	Range	Notes	
538	oy	CURRENT LOOP	CURRENT FBK.AMPS	0.0	0.0	0.0	A		V0	W4
539	oz	FIELD CONTROL	FIELD I FBK.AMPS	0.0	0.0	0.0	A		V0	W4
540	p0	ALARMS	REM TRIP INHIBIT	0	1	0		0: ENABLED 1: INHIBITED	V0	W0
541	p1	ALARMS	REM TRIP DELAY	0.1	600.0	10.0	s		V0	W0
542	p2	ALARMS	REMOTE TRIP	0	1	0			V0	W4
545	p5	DRIVE INFO	PCODE ID	0	255	3			V0	W2
547	p7	SPEED LOOP	SPD.FBK.FILTER	0.000	1.000	0.000			V0	W0
549	p9	SPEED LOOP	SPEED LOOP O/P	0.00	0.00	0.00	%		V0	W4
556	pg	INERTIA COMP	INERTIA	0.00	200.00	0.00			V0	W0
557	ph	INERTIA COMP	FILTER	0	20000	0			V0	W0
558	pi	INERTIA COMP	RATE CAL	0.00	200.00	100.00			V0	W0
559	pj	PRESET SPEEDS	MAX SPEED	0.1	3000.0	100.0	%		V0	W0
560	pk	PRESET SPEEDS	SELECT 1	0	1	0			V0	W0
561	pl	PRESET SPEEDS	SELECT 2	0	1	0			V0	W0
562	pm	PRESET SPEEDS	SELECT 3	0	1	0			V0	W0
563	pn	PRESET SPEEDS	INVERT O/P	0	1	0			V0	W0
564	po	PRESET SPEEDS	INPUT 0	-3000.0	3000.0	0.0			V0	W0
565	pp	PRESET SPEEDS	INPUT 1	-3000.0	3000.0	0.0			V0	W0
566	pq	PRESET SPEEDS	INPUT 2	-3000.0	3000.0	0.0			V0	W0
567	pr	PRESET SPEEDS	INPUT 3	-3000.0	3000.0	0.0			V0	W0
568	ps	PRESET SPEEDS	INPUT 4	-3000.0	3000.0	0.0			V0	W0
569	pt	PRESET SPEEDS	INPUT 5	-3000.0	3000.0	0.0			V0	W0
570	pu	PRESET SPEEDS	INPUT 6	-3000.0	3000.0	0.0			V0	W0
571	pv	PRESET SPEEDS	INPUT 7	-3000.0	3000.0	0.0			V0	W0
572	pw	PRESET SPEEDS	PRESET O/P	0.00	0.00	0.00	%		V0	W4
573	px	LINK	39 PRESET DEST	0	1276	0			V0	W2
574	py	SRAMP	INPUT	-100.00	100.00	0.00	%		V0	W0
575	pz	SRAMP	RATE SELECT	0	1	0			V0	W0
576	q0	SRAMP	ACCEL 0	0.00	100.00	60.00	%		V0	W0
577	q1	SRAMP	DECEL 0	0.00	100.00	60.00	%		V0	W0
578	q2	SRAMP	ACCEL 0 JERK 1	0.00	100.00	20.00	%		V0	W0
579	q3	SRAMP	ACCEL 1	0.00	100.00	30.00	%		V0	W0
580	q4	SRAMP	DECEL 1	0.00	100.00	30.00	%		V0	W0

## C-22 Parameter Specification Tables

Tag	Mn	MMI Block Name	MMI Parameter Name	Minimum	Maximum	Default	Units	Range	Notes
581	q5	SRAMP	ACCEL 1 JERK 1	0.00	100.00	20.00	%		V0 W0
582	q6	SRAMP	AUTO RESET	0	1	1			V0 W0
583	q7	SRAMP	EXTERNAL RESET	0	1	0			V0 W0
584	q8	SRAMP	RESET VALUE	-100.00	100.00	0.00	%		V0 W0
585	q9	SRAMP	QUENCH	0	1	0			V0 W0
586	qa	SRAMP	AT SPEED LEVEL	0.00	100.00	1.00	%		V0 W0
587	qb	SRAMP	AT SPEED	0	1	0			V0 W4
588	qc	SRAMP	ACCEL OUTPUT	0.00	0.00	0.00	%		V0 W4
589	qd	SRAMP	SRAMP OUTPUT	0.00	0.00	0.00	%		V0 W4
590	qe	LINK 40	SRAMP DEST	0	1276	0			V0 W2
593	qh	PRESET SPEEDS	OUTPUT FPM	0.0	0.0	0.0			V0 W4
594	qi	STOP RATES	CURR DECAY RATE	0.00	200.00	0.00			V0 W0
595	qj	SPEED LOOP	PRESET TORQUE	-250.00	250.00	0.00	%		V0 W0
596	qk	SRAMP	DECEL 0 JERK 1	0.00	100.00	20.00	%		V0 W0
597	ql	SRAMP	DECEL 1 JERK 1	0.00	100.00	20.00	%		V0 W0
600	qo	PRESET SPEEDS	LIMIT	0	1	0			V0 W0
601	qp	INERTIA COMP	DELTA	0.00	0.00	0.00	%		V0 W4
602	qq	INERTIA COMP	INERTIA COMP O/P	0.00	0.00	0.00	%		V0 W4
603	qr	INERTIA COMP	UNSCALED OUTPUT	0.00	0.00	0.00	%		V0 W4
604	qs	SPEED LOOP	PRESET T SCALE	-200.00	200.00	100.00	%		V0 W0
605	qt	FEEDBACKS	ARM VOLTS FBK	0	0	0	V		V0 W4
609	qx	AUTOTUNE	METHOD	0	1	0		0: 4Q MULTI 1: 2Q MULTI	V1 W1
610	qy	PRESET SPEEDS	GRAY SCALE	0	1	0			V0 W0
611	qz	SRAMP	ACCEL 0 JERK 2	0.00	100.00	20.00	%		V0 W0
612	r0	SRAMP	ACCEL 1 JERK 2	0.00	100.00	20.00	%		V0 W0
613	r1	SRAMP	DECEL 0 JERK 2	0.00	100.00	20.00	%		V0 W0
614	r2	SRAMP	DECEL 1 JERK 2	0.00	100.00	20.00	%		V0 W0
617	r5	FIELD CONTROL	FIELD 1 THRESH	0.00	100.00	80.00	%		V0 W0
618	r6	FIELD CONTROL	UP TO FIELD	0	1	0			V0 W4
620	r8	RAMPS	INVERT	0	1	0			V0 W0
626	re	DRIVE INFO	FRAME ID	0	0	0			V0 W4
628	rg	CONFIGURE DRIVE	UDP USE OP PORT	0	1	0			V0 W0
629	rh	LINK 13	DESTINATION TAG	0	1276	683			V0 W2

## Parameter Specification Tables C-23

Tag	Mn	MMI Block Name	MMI Parameter Name	Minimum	Maximum	Default	Units	Range	Notes
630	ri	LINK	14 DESTINATION TAG	0	1276	684			V0 W2
631	rj	LINK	15 DESTINATION TAG	0	1276	685			V0 W2
632	rk	LINK	17 DESTINATION TAG	0	1276	678			V0 W2
633	rl	LINK	18 DESTINATION TAG	0	1276	679			V0 W2
634	rm	LINK	19 DESTINATION TAG	0	1276	699			V0 W2
635	rn	LINK	20 SOURCE TAG	-1276	1276	680			V0 W2
636	ro	LINK	21 SOURCE TAG	-1276	1276	681			V0 W2
637	rp	LINK	22 SOURCE TAG	-1276	1276	682			V0 W2
638	rq	LINK	23 SOURCE TAG	-1276	1276	674			V0 W2
639	rr	LINK	24 SOURCE TAG	-1276	1276	675			V0 W2
640	rs	LINK	25 SOURCE TAG	-1276	1276	676			V0 W2
641	rt	LINK	26 SOURCE TAG	-1276	1276	677			V0 W2
642	ru	LINK	27 SOURCE TAG	-1276	1276	264			V0 W2
643	rv	LINK	28 SOURCE TAG	-1276	1276	85			V0 W2
644	rw	LINK	29 SOURCE TAG	-1276	1276	86			V0 W2
645	rx	LINK	30 SOURCE TAG	-1276	1276	417			V0 W2
646	ry	LINK	31 SOURCE TAG	-1276	1276	427			V0 W2
647	rz	LINK	32 SOURCE TAG	-1276	1276	707			V0 W2
648	s0	LINK	33 SOURCE TAG	-1276	1276	708			V0 W2
649	s1	LINK	34 SOURCE TAG	-1276	1276	441			V0 W2
650	s2	LINK	35 SOURCE TAG	-1276	1276	451			V0 W2
651	s3	LINK	36 SOURCE TAG	-1276	1276	706			V0 W2
652	s4	LINK	37 SOURCE TAG	-1276	1276	69			V0 W2
653	s5	LINK	38 SOURCE TAG	-1276	1276	70			V0 W2
654	s6	LINK	39 SOURCE TAG	-1276	1276	572			V0 W2
655	s7	LINK	40 SOURCE TAG	-1276	1276	589			V0 W2
656	s8	LINK	41 DESTINATION TAG	0	1276	687			V0 W2
657	s9	LINK	42 DESTINATION TAG	0	1276	689			V0 W2
658	sa	LINK	43 SOURCE TAG	-1276	1276	712			V0 W2
660	sc	LINK	44 SOURCE TAG	-1276	1276	713			V0 W2
662	se	LINK	45 SOURCE TAG	-1276	1276	189			V0 W2
664	sg	LINK	46 SOURCE TAG	-1276	1276	700			V0 W2
665	sh	LINK	46 DESTINATION TAG	0	1276	701			V0 W2

## C-24 Parameter Specification Tables

Tag	Mn	MMI Block Name	MMI Parameter Name	Minimum	Maximum	Default	Units	Range	Notes
666	si	LINK 47	SOURCE TAG	-1276	1276	427			V0 W2
667	sj	LINK 47	DESTINATION TAG	0	1276	709			V0 W2
668	sk	LINK 48	SOURCE TAG	-1276	1276	425			V0 W2
669	sl	LINK 48	DESTINATION TAG	0	1276	710			V0 W2
670	sm	LINK 49	SOURCE TAG	-1276	1276	691			V0 W2
671	sn	LINK 49	DESTINATION TAG	0	1276	697			V0 W2
672	so	LINK 50	SOURCE TAG	-1276	1276	475			V0 W2
673	sp	LINK 50	DESTINATION TAG	0	1276	711			V0 W2
674	sq	ANALOG INPUT 1	OUTPUT	0.00	0.00	0.00	%		V0 W4
675	sr	ANALOG INPUT 3	OUTPUT	0.00	0.00	0.00	%		V0 W4
676	ss	ANALOG INPUT 4	OUTPUT	0.00	0.00	0.00	%		V0 W4
677	st	ANALOG INPUT 5	OUTPUT	0.00	0.00	0.00	%		V0 W4
678	su	ANALOG OUTPUT 1	INPUT	-300.00	300.00	0.00	%		V0 W0
679	sv	ANALOG OUTPUT 2	INPUT	-300.00	300.00	0.00	%		V0 W0
680	sw	DIGITAL INPUT 1	OUTPUT	0.00	0.00	0.00	%		V0 W4
681	sx	DIGITAL INPUT 2	OUTPUT	0.00	0.00	0.00	%		V0 W4
682	sy	DIGITAL INPUT 3	OUTPUT	0.00	0.00	0.00	%		V0 W4
683	sz	DIGITAL OUTPUT 1	INPUT	-300.00	300.00	0.00	%		V0 W0
684	t0	DIGITAL OUTPUT 2	INPUT	-300.00	300.00	0.00	%		V0 W0
685	t1	DIGITAL OUTPUT 3	INPUT	-300.00	300.00	0.00	%		V0 W0
686	t2	ADVANCED 1	INPUT 1	-32768.00	32768.00	0.00	%		V0 W0
687	t3	ADVANCED 1	INPUT 2	-32768.00	32768.00	0.00	%		V0 W0
688	t4	ADVANCED 2	INPUT 1	-32768.00	32768.00	0.00	%		V0 W0
689	t5	ADVANCED 2	INPUT 2	-32768.00	32768.00	0.00	%		V0 W0
691	t7	MIN SPEED	OUTPUT	0.00	0.00	0.00	%		V1 W4
693	t9	COMMS PORT 1	ERROR REPORT	0x0000	0xFFFF	0x00C0			V0 W0
697	td	RAMPS	RAMP INPUT	-105.00	105.00	0.00	%		V1 W0
698	te	JOG/SLACK	JOG/SLACK	0.00	0.00	0.00	%		V1 W4
699	tf	STANDSTILL	INPUT	-300.00	300.00	0.00	%		V0 W0
700	tg	DEADBAND	OUTPUT	0.00	0.00	0.00	%		V1 W4
701	th	SETPOINT SUM 1	INPUT 1	-300.00	300.00	0.00	%		V1 W0
702	ti	SETPOINT SUM 1	OUTPUT 1	0.00	0.00	0.00	%		V0 W4
703	tj	SETPOINT SUM 1	OUTPUT 0	0.00	0.00	0.00	%		V0 W4

## Parameter Specification Tables C-25

Tag	Mn	MMI Block Name	MMI Parameter Name	Minimum	Maximum	Default	Units	Range	Notes
704	tk	SETPOINT SUM 2	SIGN 1	0	1	1		0: NEGATIVE 1: POSITIVE	V1 W0
705	tl	SETPOINT SUM 2	SIGN 0	0	1	1		0: NEGATIVE 1: POSITIVE	V1 W0
706	tm	DIAMETER CALC.	OUTPUT	0.00	0.00	0.00	%		V1 W4
707	tn	TORQUE CALC.	POS. I CLAMP	0.00	0.00	0.00	V		V0 W4
708	to	TORQUE CALC.	NEG. I CLAMP	0.00	0.00	0.00	V		V0 W4
709	tp	PROFILED GAIN	DIAMETER	0.00	100.00	10.00	%		V1 W0
710	tq	PROFILED GAIN	MIN DIAMETER	0.00	100.00	10.00	%		V1 W0
711	tr	PID	PROP. GAIN	0.0	100.0	1.0			V1 W0
712	ts	ADVANCED 1	OUTPUT	0.00	0.00	0.00	V		V0 W4
713	tt	ADVANCED 2	OUTPUT	0.00	0.00	0.00	V		V0 W4
714	tu	5703 OUT	INPUT	-300.00	300.00	0.00	%		V0 W0
720	u0	LINK 51	SOURCE TAG	-1276	1276	0			V0 W2
721	u1	LINK 51	DESTINATION TAG	0	1276	0			V0 W2
722	u2	LINK 52	SOURCE TAG	-1276	1276	0			V0 W2
723	u3	LINK 52	DESTINATION TAG	0	1276	0			V0 W2
724	u4	LINK 53	SOURCE TAG	-1276	1276	0			V0 W2
725	u5	LINK 53	DESTINATION TAG	0	1276	0			V0 W2
726	u6	LINK 54	SOURCE TAG	-1276	1276	0			V0 W2
727	u7	LINK 54	DESTINATION TAG	0	1276	0			V0 W2
728	u8	LINK 55	SOURCE TAG	-1276	1276	0			V0 W2
729	u9	LINK 55	DESTINATION TAG	0	1276	0			V0 W2
730	ua	LINK 56	SOURCE TAG	-1276	1276	0			V0 W2
731	ub	LINK 56	DESTINATION TAG	0	1276	0			V0 W2
732	uc	LINK 57	SOURCE TAG	-1276	1276	0			V0 W2
733	ud	LINK 57	DESTINATION TAG	0	1276	0			V0 W2
734	ue	LINK 58	SOURCE TAG	-1276	1276	0			V0 W2
735	uf	LINK 58	DESTINATION TAG	0	1276	0			V0 W2
736	ug	LINK 59	SOURCE TAG	-1276	1276	0			V0 W2
737	uh	LINK 59	DESTINATION TAG	0	1276	0			V0 W2
738	ui	LINK 60	SOURCE TAG	-1276	1276	0			V0 W2
739	uj	LINK 60	DESTINATION TAG	0	1276	0			V0 W2
740	uk	LINK 61	SOURCE TAG	-1276	1276	0			V0 W2



## C-26 Parameter Specification Tables

Tag	Mn	MMI Block Name	MMI Parameter Name	Minimum	Maximum	Default	Units	Range	Notes
741	ul	LINK	61 DESTINATION TAG	0	1276	0			V0 W2
742	um	LINK	62 SOURCE TAG	-1276	1276	0			V0 W2
743	un	LINK	62 DESTINATION TAG	0	1276	0			V0 W2
744	uo	LINK	63 SOURCE TAG	-1276	1276	0			V0 W2
745	up	LINK	63 DESTINATION TAG	0	1276	0			V0 W2
746	uq	LINK	64 SOURCE TAG	-1276	1276	0			V0 W2
747	ur	LINK	64 DESTINATION TAG	0	1276	0			V0 W2
748	us	LINK	65 SOURCE TAG	-1276	1276	0			V0 W2
749	ut	LINK	65 DESTINATION TAG	0	1276	0			V0 W2
750	uu	LINK	66 SOURCE TAG	-1276	1276	0			V0 W2
751	uv	LINK	66 DESTINATION TAG	0	1276	0			V0 W2
752	uw	LINK	67 SOURCE TAG	-1276	1276	0			V0 W2
753	ux	LINK	67 DESTINATION TAG	0	1276	0			V0 W2
754	uy	LINK	68 SOURCE TAG	-1276	1276	0			V0 W2
755	uz	LINK	68 DESTINATION TAG	0	1276	0			V0 W2
756	v0	LINK	69 SOURCE TAG	-1276	1276	0			V0 W2
757	v1	LINK	69 DESTINATION TAG	0	1276	0			V0 W2
758	v2	LINK	70 SOURCE TAG	-1276	1276	0			V0 W2
759	v3	LINK	70 DESTINATION TAG	0	1276	0			V0 W2
760	v4	LINK	71 SOURCE TAG	-1276	1276	0			V0 W2
761	v5	LINK	71 DESTINATION TAG	0	1276	0			V0 W2
762	v6	LINK	72 SOURCE TAG	-1276	1276	0			V0 W2
763	v7	LINK	72 DESTINATION TAG	0	1276	0			V0 W2
764	v8	LINK	73 SOURCE TAG	-1276	1276	0			V0 W2
765	v9	LINK	73 DESTINATION TAG	0	1276	0			V0 W2
766	va	LINK	74 SOURCE TAG	-1276	1276	0			V0 W2
767	vb	LINK	74 DESTINATION TAG	0	1276	0			V0 W2
768	vc	LINK	75 SOURCE TAG	-1276	1276	0			V0 W2
769	vd	LINK	75 DESTINATION TAG	0	1276	0			V0 W2
770	ve	LINK	76 SOURCE TAG	-1276	1276	0			V0 W2
771	vf	LINK	76 DESTINATION TAG	0	1276	0			V0 W2
772	vg	LINK	77 SOURCE TAG	-1276	1276	0			V0 W2
773	vh	LINK	77 DESTINATION TAG	0	1276	0			V0 W2

## Parameter Specification Tables C-27

Tag	Mn	MMI Block Name	MMI Parameter Name	Minimum	Maximum	Default	Units	Range	Notes
774	vi	LINK	78 SOURCE TAG	-1276	1276	0			V0 W2
775	vj	LINK	78 DESTINATION TAG	0	1276	0			V0 W2
776	vk	LINK	79 SOURCE TAG	-1276	1276	0			V0 W2
777	vl	LINK	79 DESTINATION TAG	0	1276	0			V0 W2
778	vm	LINK	80 SOURCE TAG	-1276	1276	0			V0 W2
779	vn	LINK	80 DESTINATION TAG	0	1276	0			V0 W2
780	vo	LOGIC FUNC	1 INPUT A	0	1	0			V0 W0
781	vp	LOGIC FUNC	1 INPUT B	0	1	0			V0 W0
782	vq	LOGIC FUNC	1 INPUT C	0	1	0			V0 W0
783	vr	LOGIC FUNC	1 TYPE	0	15	0		0: NOT(A) 1: AND(A,B,C) 2: NAND(A,B,C) 3: OR(A,B,C) 4: NOR(A,B,C) 5: XOR(A,B) 6: 0-1 EDGE(A) 7: 1-0 EDGE(A) 8: AND(A,B,!C) 9: OR(A,B,!C) 10: S FLIP-FLOP 11: R FLIP-FLOP 12: LATCH 13: SWITCH 14: (A AND B) OR C 15: (A OR B) AND C	V0 W0
784	vs	LOGIC FUNC	1 OUTPUT	0	1	0			V0 W4
785	vt	LOGIC FUNC	2 INPUT A	0	1	0			V0 W0
786	vu	LOGIC FUNC	2 INPUT B	0	1	0			V0 W0
787	vv	LOGIC FUNC	2 INPUT C	0	1	0			V0 W0
788	vw	LOGIC FUNC	2 TYPE	0	15	0		See Tag 783	V0 W0
789	vx	LOGIC FUNC	2 OUTPUT	0	1	0			V0 W4
790	vy	LOGIC FUNC	3 INPUT A	0	1	0			V0 W0
791	vz	LOGIC FUNC	3 INPUT B	0	1	0			V0 W0
792	w0	LOGIC FUNC	3 INPUT C	0	1	0			V0 W0
793	w1	LOGIC FUNC	3 TYPE	0	15	0		See Tag 783	V0 W0
794	w2	LOGIC FUNC	3 OUTPUT	0	1	0			V0 W4

## C-28 Parameter Specification Tables

Tag	Mn	MMI Block Name	MMI Parameter Name	Minimum	Maximum	Default	Units	Range	Notes
795	w3	LOGIC FUNC	4 INPUT A	0	1	0			V0 W0
796	w4	LOGIC FUNC	4 INPUT B	0	1	0			V0 W0
797	w5	LOGIC FUNC	4 INPUT C	0	1	0			V0 W0
798	w6	LOGIC FUNC	4 TYPE	0	15	0		See Tag 783	V0 W0
799	w7	LOGIC FUNC	4 OUTPUT	0	1	0			V0 W4
800	w8	LOGIC FUNC	5 INPUT A	0	1	0			V0 W0
801	w9	LOGIC FUNC	5 INPUT B	0	1	0			V0 W0
802	wa	LOGIC FUNC	5 INPUT C	0	1	0			V0 W0
803	wb	LOGIC FUNC	5 TYPE	0	15	0		See Tag 783	V0 W0
804	wc	LOGIC FUNC	5 OUTPUT	0	1	0			V0 W4
805	wd	LOGIC FUNC	6 INPUT A	0	1	0			V0 W0
806	we	LOGIC FUNC	6 INPUT B	0	1	0			V0 W0
807	wf	LOGIC FUNC	6 INPUT C	0	1	0			V0 W0
808	wg	LOGIC FUNC	6 TYPE	0	15	0		See Tag 783	V0 W0
809	wh	LOGIC FUNC	6 OUTPUT	0	1	0			V0 W4
810	wi	LOGIC FUNC	7 INPUT A	0	1	0			V0 W0
811	wj	LOGIC FUNC	7 INPUT B	0	1	0			V0 W0
812	wk	LOGIC FUNC	7 INPUT C	0	1	0			V0 W0
813	wl	LOGIC FUNC	7 TYPE	0	15	0		See Tag 783	V0 W0
814	wm	LOGIC FUNC	7 OUTPUT	0	1	0			V0 W4
815	wn	LOGIC FUNC	8 INPUT A	0	1	0			V0 W0
816	wo	LOGIC FUNC	8 INPUT B	0	1	0			V0 W0
817	wp	LOGIC FUNC	8 INPUT C	0	1	0			V0 W0
818	wq	LOGIC FUNC	8 TYPE	0	15	0		See Tag 783	V0 W0
819	wr	LOGIC FUNC	8 OUTPUT	0	1	0			V0 W4
820	ws	LOGIC FUNC	9 INPUT A	0	1	0			V0 W0
821	wt	LOGIC FUNC	9 INPUT B	0	1	0			V0 W0
822	wu	LOGIC FUNC	9 INPUT C	0	1	0			V0 W0
823	wv	LOGIC FUNC	9 TYPE	0	15	0		See Tag 783	V0 W0
824	ww	LOGIC FUNC	9 OUTPUT	0	1	0			V0 W4
825	wx	LOGIC FUNC	10 INPUT A	0	1	0			V0 W0
826	wy	LOGIC FUNC	10 INPUT B	0	1	0			V0 W0
827	wz	LOGIC FUNC	10 INPUT C	0	1	0			V0 W0

## Parameter Specification Tables C-29

Tag	Mn	MMI Block Name	MMI Parameter Name	Minimum	Maximum	Default	Units	Range	Notes
828	x0	LOGIC FUNC	10 TYPE	0	15	0		See Tag 783	V0 W0
829	x1	LOGIC FUNC	10 OUTPUT	0	1	0			V0 W4
830	x2	VALUE FUNC	1 INPUT A	-32768.00	32768.00	0.00			V0 W0
831	x3	VALUE FUNC	1 INPUT B	-32768.00	32768.00	0.00			V0 W0
832	x4	VALUE FUNC	1 INPUT C	-32768.00	32768.00	0.00			V0 W0
833	x5	VALUE FUNC	1 TYPE	0	46	0		0: IF(C) -A 1: ABS(A+B+C) 2: SWITCH(A,B) 3: (A*B)/C 4: A+B+C 5: A-B-C 6: B<=A<=C 7: A>B+/-C 8: A>=B 9: ABS(A)>B+/-C 10: ABS(A)>=B 11: A(1+B) 12: IF(C) HOLD(A) 13: BINARY DECODE 14: ON DELAY 15: OFF DELAY 16: TIMER 17: MINIMUM PULSE 18: PULSE TRAIN 19: WINDOW 20: UP/DWN COUNTER 21: (A*B)/C ROUND 22: WINDOW NO HYST 23: WIND A>=B,A<=C 24: A<=B 25: ((A*B)/100)+C 26: MIN(A,B,C) 27: MAX(A,B,C) 28: PROFILE SQRT 29: PROFILE LINEAR 30: PROFILE x^2 31: PROFILE x^3 32: PROFILE x^4 33: ON A>B, OFF A<C 34: (A+B) CLAMPED C	V0 W0

## C-30 Parameter Specification Tables

Tag	Mn	MMI Block Name	MMI Parameter Name	Minimum	Maximum	Default	Units	Range	Notes
								35: (A-B) CLAMPED C 36: (A*B) CLAMPED C 37: (A/B) CLAMPED C 38: A>=B:A, A<=C:0 39: (A * B) + C 40: A * (B + C) 41: A * (B - C) 42: A * (1+B/C) 43: A * (1+(B * C)) 44: MONOSTABLE HIGH 45: MONOSTABLE LOW 46: FILTER	
834	x6	VALUE FUNC	1 OUTPUT	0.00	0.00	0.00			V0 W4
835	x7	VALUE FUNC	2 INPUT A	-32768.00	32768.00	0.00			V0 W0
836	x8	VALUE FUNC	2 INPUT B	-32768.00	32768.00	0.00			V0 W0
837	x9	VALUE FUNC	2 INPUT C	-32768.00	32768.00	0.00			V0 W0
838	xa	VALUE FUNC	2 TYPE	0	46	0		See Tag 833	V0 W0
839	xb	VALUE FUNC	2 OUTPUT	0.00	0.00	0.00			V0 W4
840	xc	VALUE FUNC	3 INPUT A	-32768.00	32768.00	0.00			V0 W0
841	xd	VALUE FUNC	3 INPUT B	-32768.00	32768.00	0.00			V0 W0
842	xe	VALUE FUNC	3 INPUT C	-32768.00	32768.00	0.00			V0 W0
843	xf	VALUE FUNC	3 TYPE	0	46	0		See Tag 833	V0 W0
844	xg	VALUE FUNC	3 OUTPUT	0.00	0.00	0.00			V0 W4
845	xh	VALUE FUNC	4 INPUT A	-32768.00	32768.00	0.00			V0 W0
846	xi	VALUE FUNC	4 INPUT B	-32768.00	32768.00	0.00			V0 W0
847	xj	VALUE FUNC	4 INPUT C	-32768.00	32768.00	0.00			V0 W0
848	xk	VALUE FUNC	4 TYPE	0	46	0		See Tag 833	V0 W0
849	xl	VALUE FUNC	4 OUTPUT	0.00	0.00	0.00			V0 W4
850	xm	VALUE FUNC	5 INPUT A	-32768.00	32768.00	0.00			V0 W0
851	xn	VALUE FUNC	5 INPUT B	-32768.00	32768.00	0.00			V0 W0
852	xo	VALUE FUNC	5 INPUT C	-32768.00	32768.00	0.00			V0 W0
853	xp	VALUE FUNC	5 TYPE	0	46	0		See Tag 833	V0 W0
854	xq	VALUE FUNC	5 OUTPUT	0.00	0.00	0.00			V0 W4
855	xr	VALUE FUNC	6 INPUT A	-32768.00	32768.00	0.00			V0 W0
856	xs	VALUE FUNC	6 INPUT B	-32768.00	32768.00	0.00			V0 W0

## Parameter Specification Tables C-31

Tag	Mn	MMI Block Name	MMI Parameter Name	Minimum	Maximum	Default	Units	Range	Notes
857	xt	VALUE FUNC	6 INPUT C	-32768.00	32768.00	0.00			V0 W0
858	xu	VALUE FUNC	6 TYPE	0	46	0		See Tag 833	V0 W0
859	xv	VALUE FUNC	6 OUTPUT	0.00	0.00	0.00			V0 W4
860	xw	VALUE FUNC	7 INPUT A	-32768.00	32768.00	0.00			V0 W0
861	xx	VALUE FUNC	7 INPUT B	-32768.00	32768.00	0.00			V0 W0
862	xy	VALUE FUNC	7 INPUT C	-32768.00	32768.00	0.00			V0 W0
863	xz	VALUE FUNC	7 TYPE	0	46	0		See Tag 833	V0 W0
864	y0	VALUE FUNC	7 OUTPUT	0.00	0.00	0.00			V0 W4
865	y1	VALUE FUNC	8 INPUT A	-32768.00	32768.00	0.00			V0 W0
866	y2	VALUE FUNC	8 INPUT B	-32768.00	32768.00	0.00			V0 W0
867	y3	VALUE FUNC	8 INPUT C	-32768.00	32768.00	0.00			V0 W0
868	y4	VALUE FUNC	8 TYPE	0	46	0		See Tag 833	V0 W0
869	y5	VALUE FUNC	8 OUTPUT	0.00	0.00	0.00			V0 W4
870	y6	VALUE FUNC	9 INPUT A	-32768.00	32768.00	0.00			V0 W0
871	y7	VALUE FUNC	9 INPUT B	-32768.00	32768.00	0.00			V0 W0
872	y8	VALUE FUNC	9 INPUT C	-32768.00	32768.00	0.00			V0 W0
873	y9	VALUE FUNC	9 TYPE	0	46	0		See Tag 833	V0 W0
874	ya	VALUE FUNC	9 OUTPUT	0.00	0.00	0.00			V0 W4
875	yb	VALUE FUNC	10 INPUT A	-32768.00	32768.00	0.00			V0 W0
876	yc	VALUE FUNC	10 INPUT B	-32768.00	32768.00	0.00			V0 W0
877	yd	VALUE FUNC	10 INPUT C	-32768.00	32768.00	0.00			V0 W0
878	ye	VALUE FUNC	10 TYPE	0	46	0		See Tag 833	V0 W0
879	yf	VALUE FUNC	10 OUTPUT	0.00	0.00	0.00			V0 W4
880	yg	DEMULTIPLEXER	OUTPUT 0	0	1	0			V0 W4
881	yh	DEMULTIPLEXER	OUTPUT 1	0	1	0			V0 W4
882	yi	DEMULTIPLEXER	OUTPUT 2	0	1	0			V0 W4
883	yj	DEMULTIPLEXER	OUTPUT 3	0	1	0			V0 W4
884	yk	DEMULTIPLEXER	OUTPUT 4	0	1	0			V0 W4
885	yl	DEMULTIPLEXER	OUTPUT 5	0	1	0			V0 W4
886	ym	DEMULTIPLEXER	OUTPUT 6	0	1	0			V0 W4
887	yn	DEMULTIPLEXER	OUTPUT 7	0	1	0			V0 W4
888	yo	DEMULTIPLEXER	OUTPUT 8	0	1	0			V0 W4
889	yp	DEMULTIPLEXER	OUTPUT 9	0	1	0			V0 W4

## C-32 Parameter Specification Tables

Tag	Mn	MMI Block Name	MMI Parameter Name	Minimum	Maximum	Default	Units	Range	Notes	
890	yq	DEMULTIPLEXER	OUTPUT 10	0	1	0			V0	W4
891	yr	DEMULTIPLEXER	OUTPUT 11	0	1	0			V0	W4
892	ys	DEMULTIPLEXER	OUTPUT 12	0	1	0			V0	W4
893	yt	DEMULTIPLEXER	OUTPUT 13	0	1	0			V0	W4
894	yu	DEMULTIPLEXER	OUTPUT 14	0	1	0			V0	W4
895	yv	DEMULTIPLEXER	OUTPUT 15	0	1	0			V0	W4
896	yw	DEMULTIPLEXER	INPUT	0x0000	0xFFFF	0x0000			V0	W0
897	yx	5703 OUT	DELAY	0	1000	0	ms		V0	W0
1128	hK	MULTIPLEXER	OUTPUT	0x0000	0xFFFF	0x0000			V0	W4
1129	hL	MULTIPLEXER	INPUT 0	0	1	0			V0	W0
1130	hM	MULTIPLEXER	INPUT 1	0	1	0			V0	W0
1131	hN	MULTIPLEXER	INPUT 2	0	1	0			V0	W0
1132	hO	MULTIPLEXER	INPUT 3	0	1	0			V0	W0
1133	hP	MULTIPLEXER	INPUT 4	0	1	0			V0	W0
1134	hQ	MULTIPLEXER	INPUT 5	0	1	0			V0	W0
1135	hR	MULTIPLEXER	INPUT 6	0	1	0			V0	W0
1136	hS	MULTIPLEXER	INPUT 7	0	1	0			V0	W0
1137	hT	MULTIPLEXER	INPUT 8	0	1	0			V0	W0
1138	hU	MULTIPLEXER	INPUT 9	0	1	0			V0	W0
1139	hV	MULTIPLEXER	INPUT 10	0	1	0			V0	W0
1140	hW	MULTIPLEXER	INPUT 11	0	1	0			V0	W0
1141	hX	MULTIPLEXER	INPUT 12	0	1	0			V0	W0
1142	hY	MULTIPLEXER	INPUT 13	0	1	0			V0	W0
1143	hZ	MULTIPLEXER	INPUT 14	0	1	0			V0	W0
1144	iA	MULTIPLEXER	INPUT 15	0	1	0			V0	W0
1145	iB	SELECT	1 INPUT 0	-32768.00	32768.00	0.00			V0	W0
1146	iC	SELECT	1 INPUT 1	-32768.00	32768.00	0.00			V0	W0
1147	iD	SELECT	1 INPUT 2	-32768.00	32768.00	0.00			V0	W0
1148	iE	SELECT	1 INPUT 3	-32768.00	32768.00	0.00			V0	W0
1149	iF	SELECT	1 INPUT 4	-32768.00	32768.00	0.00			V0	W0
1150	iG	SELECT	1 INPUT 5	-32768.00	32768.00	0.00			V0	W0
1151	iH	SELECT	1 INPUT 6	-32768.00	32768.00	0.00			V0	W0
1152	iI	SELECT	1 INPUT 7	-32768.00	32768.00	0.00			V0	W0

## Parameter Specification Tables C-33

Tag	Mn	MMI Block Name	MMI Parameter Name	Minimum	Maximum	Default	Units	Range	Notes
1153	iJ	SELECT 1	SELECT	0	7	0			V0 W0
1154	iK	SELECT 1	OUTPUT 0	0.00	0.00	0.00			V0 W4
1155	iL	SELECT 1	OUTPUT 1	0.00	0.00	0.00			V0 W4
1156	iM	SELECT 2	INPUT 0	-32768.00	32768.00	0.00			V0 W0
1157	iN	SELECT 2	INPUT 1	-32768.00	32768.00	0.00			V0 W0
1158	iO	SELECT 2	INPUT 2	-32768.00	32768.00	0.00			V0 W0
1159	iP	SELECT 2	INPUT 3	-32768.00	32768.00	0.00			V0 W0
1160	iQ	SELECT 2	INPUT 4	-32768.00	32768.00	0.00			V0 W0
1161	iR	SELECT 2	INPUT 5	-32768.00	32768.00	0.00			V0 W0
1162	iS	SELECT 2	INPUT 6	-32768.00	32768.00	0.00			V0 W0
1163	iT	SELECT 2	INPUT 7	-32768.00	32768.00	0.00			V0 W0
1164	iU	SELECT 2	SELECT	0	7	0			V0 W0
1165	iV	SELECT 2	OUTPUT 0	0.00	0.00	0.00			V0 W4
1166	iW	SELECT 2	OUTPUT 1	0.00	0.00	0.00			V0 W4
1169	iZ	CONFIGURE DRIVE	DUMP CHANGED	0	1	0			V1 W1
1172	jC	CONFIGURE DRIVE	DEBOUNCE DIGIN	0	1	1			V0 W0
1174	jE	CURRENT LOOP	PHASE ANGLE @ E	0.00	0.00	0.00	DEG		V0 W4
1175	jF	COMMS PORT 3	REPLY DELAY	0	255	2	ms		V0 W0
1185	jP	FIELD CONTROL	WEAK PID ERROR	0.00	0.00	0.00	%		V1 W4
1186	jQ	FIELD CONTROL	WEAK PID OUT	0.00	0.00	0.00	%		V1 W4
1187	jR	FIELD CONTROL	FIELD STATE	0	6	0		0: FIELD INIT 1: FIELD QUENCH 2: FIELD STANDBY 3: FIELD FULL FLD 4: FIELD TIMER 5: FIELD ERROR 6: LOCAL BEMF	V0 W4
1188	jS	LINK 11	DESTINATION TAG	0	1276	686			V0 W2
1189	jT	LINK 12	DESTINATION TAG	0	1276	688			V0 W2
1190	jU	LINK 16	DESTINATION TAG	0	1276	714			V0 W2



## C-34 Parameter Specification Tables

Tag	Mn	MMI Block Name	MMI Parameter Name	Minimum	Maximum	Default	Units	Range	Notes
1198	kC	PLL	PLL STATE	0	6	0		0: STOPPED 1: 1ST CODING EDGE 2: READ EDGES 3: MAINS PERIOD 4: LOCKED 5: UNLOCKED 6: FAIL	V0 W4
1199	kD	PLL	PHASE ERROR	0.00	0.00	0.00			V0 W4
1201	kF	PLL	PLL MAINS FREQ	0.00	0.00	0.00			V0 W4
1204	kI	SEQUENCING	COMMS TIMEOUT	0.0	60.0	0.0	s		V0 W0
1220	kY	CONFIGURE DRIVE	AUTOMATIC SAVE	0	1	0			V0 W0
1226	IE	AUTOTUNE	STATE	0	3	0		0: IDLE 1: RUNNING 2: SUCCESS 3: FAILED	V1 W4
1227	IF	ENCODER 1	SPEED FEEDBACK	0.0	0.0	0.0	%		V0 W4
1230	II	ENCODER 2	ENCODER LINES	10	5000	1000			V0 W1
1231	IJ	ENCODER 2	ENCODER SIGN	0	1	1		0: NEGATIVE 1: POSITIVE	V0 W1
1232	IK	ENCODER 2	ENCODER RPM	0	6000	1000	RPM		V0 W1
1235	IN	ENCODER 2	UNFIL.ENCODER	0	0	0	RPM		V0 W4
1236	IO	ENCODER 2	ENCODER	0	0	0	RPM		V0 W4
1237	IP	ENCODER 2	SPEED FEEDBACK	0.0	0.0	0.0	%		V0 W4
1238	IQ	DIGITAL INPUT 4	OUTPUT	0.00	0.00	0.00	%		V0 W4
1239	IR	DIGITAL INPUT 4	VALUE FOR TRUE	-300.00	300.00	0.01	%		V0 W0
1240	IS	DIGITAL INPUT 4	VALUE FOR FALSE	-300.00	300.00	0.00	%		V0 W0
1241	IT	DIGITAL INPUT 5	OUTPUT	0.00	0.00	0.00	%		V0 W4
1242	IU	DIGITAL INPUT 5	VALUE FOR TRUE	-300.00	300.00	0.01	%		V0 W0
1243	IV	DIGITAL INPUT 5	VALUE FOR FALSE	-300.00	300.00	0.00	%		V0 W0
1246	IY	ALARM HISTORY	ALARM 1 NEWEST	0x0000	0xFFFF	0x0000			V0 W4
1247	IZ	ALARM HISTORY	ALARM 2	0x0000	0xFFFF	0x0000			V0 W4
1248	mA	ALARM HISTORY	ALARM 3	0x0000	0xFFFF	0x0000			V0 W4
1249	mB	ALARM HISTORY	ALARM 4	0x0000	0xFFFF	0x0000			V0 W4
1250	mC	ALARM HISTORY	ALARM 5	0x0000	0xFFFF	0x0000			V0 W4
1251	mD	ALARM HISTORY	ALARM 6	0x0000	0xFFFF	0x0000			V0 W4

## Parameter Specification Tables C-35

Tag	Mn	MMI Block Name	MMI Parameter Name	Minimum	Maximum	Default	Units	Range	Notes
1252	mE	ALARM HISTORY	ALARM 7	0x0000	0xFFFF	0x0000			V0 W4
1253	mF	ALARM HISTORY	ALARM 8	0x0000	0xFFFF	0x0000			V0 W4
1254	mG	ALARM HISTORY	ALARM 9	0x0000	0xFFFF	0x0000			V0 W4
1255	mH	ALARM HISTORY	ALARM 10 OLDEST	0x0000	0xFFFF	0x0000			V0 W4
1259	mL	PID	HI RES PROP GAIN	0.000	100.000	0.000			V1 W0
1267	mT	ENCODER 1	ENCODER TYPE	0	1	1		0: CLOCK/DIRECTION 1: QUADRATURE	V0 W1
1268	mU	ENCODER 2	ENCODER TYPE	0	1	1		0: CLOCK/DIRECTION 1: QUADRATURE	V0 W1
1273	mZ	FIELD CONTROL	BEMF SOURCE	0	1	0		0: LOCAL BEMF 1: BEMF INPUT	V1 W1
1274	nA	FIELD CONTROL	BEMF INPUT	-200.00	200.00	0.00	%		V1 W0
1275	nB	CURRENT LOOP	ISOL DMD SOURCE	0	1	0		0: ANIN 2 (A3) 1: FIELD I DEMAND	V1 W1
1276	nC	AUTOTUNE	ERROR TYPE	0	11	0		0: NO ERROR 1: OVER SPEED 2: FIELD ERROR 3: PULSE WIDTH 4: OVER CURRENT 5: TIMEOUT 6: AUTOTUNE ABORTED 7: FIRING ANGLE 8: PEAK/AVER. RATIO 9: UNBALANCED BRID. 10: NULL AVERAGE CUR 11: THYRISTOR OFF	V1 W4

## C-36 Parameter Specification Tables

# Parameter Table: MMI Menu Order

---

.....DIAGNOSTICS		
.....SPEED DEMAND	[0089]	Speed Loop
.....SPEED FEEDBACK	[0207]	Feedbacks
.....SPEED ERROR	[0297]	Speed Loop
.....SPEED LOOP O/P	[0549]	Speed Loop
.....CURRENT DEMAND	[0299]	Current Loop
.....CURRENT FEEDBACK	[0298]	Feedbacks
.....CURRENT FBK.AMPS	[0538]	Current Loop
.....IaFbk UNFILTERED	[0065]	Current Loop
.....IaDmd UNFILTERED	[0066]	Current Loop
a.....POS. I CLAMP	[0087]	Current Loop
a.....NEG. I CLAMP	[0088]	Current Loop
.....ACTUAL POS I LIM	[0067]	Current Loop
.....ACTUAL NEG I LIM	[0061]	Current Loop
a.....INVERSE TIME O/P	[0203]	Inverse Time
a.....AT CURRENT LIMIT	[0042]	Current Loop
.....AT ZERO SPEED	[0077]	Standstill
a.....AT ZERO SETPOINT	[0078]	Standstill
a.....AT STANDSTILL	[0079]	Standstill
a.....RAMPING	[0113]	Ramps
a.....PROGRAM STOP	[0080]	Sequencing
.....COAST STOP	[0525]	Sequencing
.....DRIVE START	[0082]	Sequencing
.....DRIVE ENABLE	[0084]	Sequencing
a.....OPERATING MODE	[0212]	Jog/Slack
.....FIELD ENABLED	[0169]	Field Control
a.....FIELD DEMAND	[0183]	Field Control
.....FIELD I FBK.	[0300]	Field Control
.....FIELD I FBK.AMPS	[0539]	Field Control
.....UNFIL.FIELD FBK	[0181]	Feedbacks
a.....FLD.FIRING ANGLE	[0184]	Field Control
a.....ANIN 1 (A2)	[0050]	Analog Input
a.....ANIN 2 (A3)	[0051]	Analog Input

a.....ANIN 3 (A4)	[0052]	Analog Input
a.....ANIN 4 (A5)	[0053]	Analog Input
a.....ANIN 5 (A6)	[0054]	Analog Input
a.....ANOUT 1 (A7)	[0055]	Analog Output
a.....ANOUT 2 (A8)	[0056]	Analog Output
a.....START (C3)	[0068]	Sequencing
a.....DIGITAL INPUT C4	[0069]	Digital Input
a.....DIGITAL INPUT C5	[0070]	Digital Input
a.....DIGIN 1 (C6)	[0071]	Digital Input
a.....DIGIN 2 (C7)	[0072]	Digital Input
a.....DIGIN 3 (C8)	[0073]	Digital Input
a.....DIGOUT 1 (B5)	[0074]	Digital Output
a.....DIGOUT 2 (B6)	[0075]	Digital Output
a.....DIGOUT 3 (B7)	[0076]	Digital Output
.....RAISE/LOWER O/P	[0264]	Raise/Lower
a.....PID OUTPUT	[0417]	PID
a.....PID CLAMPED	[0416]	PID
a.....PID ERROR	[0415]	PID
a.....SPT SUM OUTPUT	[0086]	Setpoint Sum
a.....RAMP OUTPUT	[0085]	Ramps
.....PRESET O/P	[0572]	Preset Speeds
.....SRAMP OUTPUT	[0589]	Sramp
.....OUTPUT FPM	[0593]	Preset Speeds
.....SPEED SETPOINT	[0063]	Speed Loop
a.....TERMINAL VOLTS	[0057]	Calibration
.....BACK EMF	[0060]	Calibration
.....ARM VOLTS FBK	[0605]	Feedbacks
.....TACH INPUT	[0308]	Feedbacks
.....UNFIL.TACH INPUT	[0058]	Calibration
.....ENCODER	[0206]	Encoder
.....UNFIL.ENCODER	[0059]	Encoder
.....UNFIL.SPD.FBK	[0062]	Speed Loop
.....UNFIL.SPD.ERROR	[0064]	Speed Loop
.....CONTACTOR CLOSED	[0083]	Sequencing
.....HEALTH LED	[0122]	Alarms
.....READY	[0125]	Sequencing

## C-38 Parameter Specification Tables

.....DRIVE RUNNING	[0376]	Sequencing
.....SYSTEM RESET	[0374]	Sequencing
..... <b>SETUP PARAMETERS</b>		
.....RAMPS		
.....RAMP ACCEL TIME	[0002]	Ramps
.....RAMP DECEL TIME	[0003]	Ramps
a.....RAMP HOLD	[0118]	Ramps
.....INVERT	[0620]	Ramps
a.....RAMP INPUT	[0005]	Min Speed
a.....% S-RAMP	[0266]	Ramps
a.....RAMPING THRESH.	[0286]	Ramps
a.....AUTO RESET	[0287]	Ramps
a.....EXTERNAL RESET	[0288]	Ramps
a.....RESET VALUE	[0422]	Ramps
a.....MIN SPEED	[0126]	Min Speed
a.....AUX I/O		
.....AUX START	[0161]	Sequencing
.....AUX JOG	[0227]	Sequencing
.....AUX ENABLE	[0168]	Sequencing
.....AUX DIGOUT 1	[0094]	Aux I/O
.....AUX DIGOUT 2	[0095]	Aux I/O
.....AUX DIGOUT 3	[0096]	Aux I/O
.....ANOUT 1	[0128]	Aux I/O
.....ANOUT 2	[0129]	Aux I/O
.....JOG/SLACK	[0496]	Sequencing
.....ENABLE	[0497]	Sequencing
.....REM.SEQ.ENABLE	[0535]	Sequencing
a.....REM.SEQUENCE	[0536]	Sequencing
.....SEQ STATUS	[0537]	Sequencing
.....OP-STATION		
.....SET UP		
.....SETPOINT	[0512]	Op-Station
.....JOG SETPOINT	[0513]	Op-Station
.....LOCAL KEY ENABLE	[0511]	Op-Station
.....START UP VALUES		
.....INITIAL SETPOINT	[0519]	Op-Station

.....INITIAL JOG	[0520]	Op-Station
.....INITIAL DIR	[0516]	Op-Station
.....INITIAL VIEW	[0518]	Op-Station
.....INITIAL MODE	[0517]	Op-Station
.....LOCAL RAMP		
.....RAMP ACCEL TIME	[0514]	Op-Station
.....RAMP DECEL TIME	[0515]	Op-Station
.....JOG/SLACK		
.....JOG SPEED 1	[0218]	Jog/Slack
.....JOG SPEED 2	[0219]	Jog/Slack
.....TAKE UP 1	[0253]	Jog/Slack
.....TAKE UP 2	[0254]	Jog/Slack
.....CRAWL SPEED	[0225]	Jog/Slack
.....MODE	[0228]	Jog/Slack
.....RAMP RATE	[0355]	Jog/Slack
a.....RAISE/LOWER		
.....RESET VALUE	[0255]	Raise/Lower
.....INCREASE RATE	[0256]	Raise/Lower
.....DECREASE RATE	[0257]	Raise/Lower
.....RAISE INPUT	[0261]	Raise/Lower
.....LOWER INPUT	[0262]	Raise/Lower
.....MIN VALUE	[0258]	Raise/Lower
.....MAX VALUE	[0259]	Raise/Lower
a.....EXTERNAL RESET	[0307]	Raise/Lower
.....PRESET SPEEDS		
.....SELECT 1	[0560]	Preset Speeds
.....SELECT 2	[0561]	Preset Speeds
.....SELECT 3	[0562]	Preset Speeds
.....INVERT O/P	[0563]	Preset Speeds
.....MAX SPEED	[0559]	Preset Speeds
.....LIMIT	[0600]	Preset Speeds
.....GRAY SCALE	[0610]	Preset Speeds
.....INPUT 0	[0564]	Preset Speeds
.....INPUT 1	[0565]	Preset Speeds
.....INPUT 2	[0566]	Preset Speeds
.....INPUT 3	[0567]	Preset Speeds

## C-40 Parameter Specification Tables

.....INPUT 4	[0568]	Preset Speeds
.....INPUT 5	[0569]	Preset Speeds
.....INPUT 6	[0570]	Preset Speeds
.....INPUT 7	[0571]	Preset Speeds
.....PRESET O/P	[0572]	Preset Speeds
.....OUTPUT FPM	[0593]	Preset Speeds
.....SRAMP		
.....INPUT	[0574]	Sramp
.....RATE SELECT	[0575]	Sramp
.....RATE SET 0		
.....ACCEL 0	[0576]	Sramp
.....DECEL 0	[0577]	Sramp
.....ACCEL 0 JERK 1	[0578]	Sramp
.....ACCEL 0 JERK 2	[0611]	Sramp
.....DECEL 0 JERK 1	[0596]	Sramp
.....DECEL 0 JERK 2	[0613]	Sramp
.....RATE SET 1		
.....ACCEL 1	[0579]	Sramp
.....DECEL 1	[0580]	Sramp
.....ACCEL 1 JERK 1	[0581]	Sramp
.....ACCEL 1 JERK 2	[0612]	Sramp
.....DECEL 1 JERK 1	[0597]	Sramp
.....DECEL 1 JERK 2	[0614]	Sramp
.....AUTO RESET	[0582]	Sramp
.....EXTERNAL RESET	[0583]	Sramp
.....RESET VALUE	[0584]	Sramp
.....QUENCH	[0585]	Sramp
.....AT SPEED LEVEL	[0586]	Sramp
.....AT SPEED	[0587]	Sramp
.....ACCEL OUTPUT	[0588]	Sramp
.....SRAMP OUTPUT	[0589]	Sramp
a.....SPECIAL BLOCKS		
a.....PID		
a.....PROP. GAIN	[0404]	Profiled Gain
a.....INT.TIME.CONST	[0402]	PID
a.....DERIVATIVE TC	[0401]	PID

## Parameter Specification Tables C-41

a.....	POSITIVE LIMIT	[0405]	PID
a.....	NEGATIVE LIMIT	[0406]	PID
a.....	O/P SCALER(TRIM)	[0407]	PID
a.....	INPUT 1	[0410]	PID
a.....	INPUT 2	[0411]	PID
a.....	RATIO 1	[0412]	PID
a.....	RATIO 2	[0413]	PID
a.....	DIVIDER 1	[0418]	PID
a.....	DIVIDER 2	[0414]	PID
a.....	ENABLE	[0408]	PID
a.....	INT. DEFEAT	[0409]	PID
a.....	FILTER T.C.	[0403]	PID
a.....	MODE	[0473]	Profiled Gain
a.....	MIN PROFILE GAIN	[0474]	Profiled Gain
a.....	PROFILED GAIN	[0475]	Profiled Gain
a.....	TENS+COMP CALC.		
.....	STATIC COMP	[0487]	Diameter Calc
.....	DYNAMIC COMP	[0488]	Diameter Calc
.....	REWIND	[0489]	Diameter Calc
a.....	FIX.INERTIA COMP	[0479]	Diameter Calc
a.....	VAR.INERTIA COMP	[0480]	Diameter Calc
a.....	ROLL WIDTH/MASS	[0481]	Diameter Calc
.....	LINE SPEED SPT	[0498]	Diameter Calc
a.....	FILTER T.C.	[0482]	Diameter Calc
a.....	RATE CAL	[0483]	Diameter Calc
a.....	NORMALISED dv/dt	[0484]	Diameter Calc
a.....	INERTIA COMP O/P	[0485]	Diameter Calc
a.....	TENSION SCALER	[0486]	Diameter Calc
a.....	DIAMETER CALC.		
a.....	LINE SPEED	[0424]	Diameter Calc
a.....	REEL SPEED	[0437]	Diameter Calc
a.....	MIN DIAMETER	[0425]	Diameter Calc
a.....	MIN SPEED	[0426]	Diameter Calc
a.....	RESET VALUE	[0462]	Diameter Calc
a.....	EXTERNAL RESET	[0463]	Diameter Calc
a.....	RAMP RATE	[0453]	Diameter Calc



## C-42 Parameter Specification Tables

a.....DIAMETER	[0427]	Diameter Calc
.....MOD OF LINE SPD	[0428]	Diameter Calc
.....MOD OF REEL SPD	[0429]	Diameter Calc
.....UNFILT DIAMETER	[0430]	Diameter Calc
a.....TAPER CALC.		
a.....TAPER	[0438]	Diameter Calc
a.....TENSION SPT.	[0439]	Diameter Calc
a.....TAPERED DEMAND	[0452]	Diameter Calc
a.....TENSION TRIM	[0440]	Diameter Calc
a.....TOT.TENS.DEMAND	[0441]	Diameter Calc
a.....TORQUE CALC.		
a.....TORQUE DEMAND	[0432]	Torque Calc.
a.....TENSION ENABLE	[0433]	Torque Calc.
a.....OVER WIND	[0434]	Torque Calc.
a.....SETPOINT SUM 2		
a.....INPUT 2	[0445]	Setpoint Sum
a.....INPUT 1	[0443]	Setpoint Sum
a.....INPUT 0	[0444]	Setpoint Sum
.....RATIO 1	[0446]	Setpoint Sum
.....RATIO 0	[0447]	Setpoint Sum
a.....DIVIDER 1	[0466]	Setpoint Sum
.....DIVIDER 0	[0448]	Setpoint Sum
.....LIMIT	[0449]	Setpoint Sum
a.....SPT SUM OUTPUT	[0451]	Setpoint Sum
.....STPT SUM 2 OUT 0	[0491]	Setpoint Sum
.....STPT SUM 2 OUT 1	[0492]	Setpoint Sum
.....FIELD CONTROL		
.....FIELD ENABLE	[0170]	Field Control
.....FLD.CTRL MODE	[0209]	Field Control
.....FIELD I THRESH	[0617]	Field Control
.....UP TO FIELD	[0618]	Field Control
.....FLD.VOLTAGE VARS		
.....FLD.VOLTS RATIO	[0210]	Field Control
.....FLD.CURRENT VARS		
a.....SETPOINT	[0171]	Field Control
.....PROP. GAIN	[0173]	Field Control

.....INT. GAIN	[0172]	Field Control
a.....FLD.WEAK VARS		
.....FLD. WEAK ENABLE	[0174]	Field Control
.....EMF LEAD	[0175]	Field Control
.....EMF LAG	[0176]	Field Control
.....EMF GAIN	[0177]	Field Control
.....MIN FLD.CURRENT	[0179]	Field Control
.....MAX VOLTS	[0178]	Field Control
.....BEMF FBK LEAD	[0191]	Field Control
.....BEMF FBK LAG	[0192]	Field Control
a.....FLD.QUENCH DELAY	[0185]	Field Control
a.....FLD. QUENCH MODE	[0186]	Field Control
a.....CURRENT PROFILE		
.....SPD BRK1 (LOW)	[0032]	Current Profile
.....SPD BRK2 (HIGH)	[0031]	Current Profile
.....IMAX BRK1 (SPD1)	[0093]	Current Profile
.....IMAX BRK2 (SPD2)	[0033]	Current Profile
.....STOP RATES		
.....STOP TIME	[0027]	Stop Rates
a.....STOP LIMIT	[0217]	Stop Rates
a.....CONTACTOR DELAY	[0302]	Stop Rates
.....CURR DECAY RATE	[0594]	Stop Rates
.....PROG STOP TIME	[0026]	Stop Rates
a.....PROG STOP LIMIT	[0216]	Stop Rates
.....PROG STOP I LIM	[0091]	Stop Rates
.....STOP ZERO SPEED	[0029]	Stop Rates
.....CALIBRATION		
.....CONFIGURE ENABLE	[0039]	Configure Drive
.....NOM MOTOR VOLTS	[0521]	Configure Drive
.....ARMATURE CURRENT	[0523]	Configure Drive
.....FIELD CURRENT	[0524]	Configure Drive
.....ARMATURE V CAL.	[0020]	Calibration
.....IR COMPENSATION	[0021]	Calibration
.....ENCODER RPM	[0022]	Encoder
.....ENCODER LINES	[0024]	Encoder
.....ANALOG TACH CAL	[0023]	Calibration

## C-44 Parameter Specification Tables

.....ZERO SPD. OFFSET	[0010]	Calibration
.....ARMATURE I (A9)	[0025]	Calibration
a.....SPDFBK ALM LEVEL	[0180]	Alarms
a.....STALL THRESHOLD	[0263]	Alarms
a.....STALL TRIP DELAY	[0224]	Alarms
.....REM TRIP DELAY	[0541]	Alarms
.....FIELD I CAL.	[0182]	Calibration
.....INHIBIT ALARMS		
.....FIELD FAIL	[0019]	Alarms
.....5703 RCV ERROR	[0111]	Alarms
a.....STALL TRIP	[0028]	Alarms
a.....TRIP RESET	[0305]	Alarms
.....SPEED FBK ALARM	[0081]	Alarms
.....ENCODER ALARM	[0092]	Alarms
.....REM TRIP INHIBIT	[0540]	Alarms
.....CURRENT LOOP		
.....MAIN CURR. LIMIT	[0421]	Current Loop
.....PROP. GAIN	[0016]	Current Loop
.....INT. GAIN	[0017]	Current Loop
.....AUTOTUNE	[0018]	Auto-Tune
.....DISCONTINUOUS	[0137]	Current Loop
a.....ADDITIONAL DEM	[0030]	Current Loop
a.....BIPOLAR CLAMPS	[0090]	Current Loop
.....REGEN ENABLE	[0201]	Current Loop
.....MASTER BRIDGE	[0527]	Current Loop
.....POS. I CLAMP IN	[0301]	Current Loop
a.....NEG. I CLAMP IN	[0048]	Current Loop
a.....I DMD. ISOLATE	[0119]	Current Loop
.....CUR.LIMIT/SCALER	[0015]	Current Loop
.....SPEED LOOP		
.....SPD.PROP.GAIN	[0014]	Speed Loop
.....SPD.INT.TIME	[0013]	Speed Loop
a.....INT. DEFEAT	[0202]	Speed Loop
.....PRESET TORQUE	[0595]	Speed Loop
.....PRESET T SCALE	[0604]	Speed Loop
.....ENCODER SIGN	[0049]	Encoder

## Parameter Specification Tables C-45

.....SPEED FBK SELECT	[0047]	Speed Loop
.....SPD.FBK.FILTER	[0547]	Speed Loop
a.....ADVANCED		
.....ADAPTION		
.....MODE	[0268]	Speed Loop
.....SPD BRK1 (LOW)	[0269]	Speed Loop
.....SPD BRK2 (HIGH)	[0270]	Speed Loop
.....PROP. GAIN	[0271]	Speed Loop
.....INT.TIME.CONST	[0272]	Speed Loop
.....I GAIN IN RAMP	[0274]	Speed Loop
.....ZERO SPD. QUENCH		
.....ZERO SPD. LEVEL	[0284]	Speed Loop
.....ZERO IAD LEVEL	[0285]	Speed Loop
.....INERTIA COMP		
.....INERTIA	[0556]	Inertia Comp
.....FILTER	[0557]	Inertia Comp
.....RATE CAL	[0558]	Inertia Comp
.....DELTA	[0601]	Inertia Comp
.....UNSCALED OUTPUT	[0603]	Inertia Comp
.....INERTIA COMP O/P	[0602]	Inertia Comp
.....SETPOINTS		
.....SETPOINT 1	[0289]	Speed Loop
.....SIGN 2 (A3)	[0009]	Speed Loop
.....RATIO 2 (A3)	[0007]	Speed Loop
.....SETPOINT 2 (A3)	[0290]	Speed Loop
.....SETPOINT 3	[0291]	Speed Loop
.....SETPOINT 4	[0041]	Speed Loop
.....MAX DEMAND	[0357]	Speed Loop
.....MIN DEMAND	[0358]	Speed Loop
.....STANDSTILL		
.....STANDSTILL LOGIC	[0011]	Standstill
.....ZERO THRESHOLD	[0012]	Standstill
.....SOURCE TAG	[0306]	Link
.....SETPOINT SUM 1		
.....RATIO 1	[0006]	Setpoint Sum
.....RATIO 0	[0208]	Setpoint Sum

## C-46 Parameter Specification Tables

a.....SIGN 1	[0008]	Setpoint Sum
a.....SIGN 0	[0292]	Setpoint Sum
a.....DIVIDER 1	[0419]	Setpoint Sum
.....DIVIDER 0	[0420]	Setpoint Sum
.....DEADBAND WIDTH	[0131]	Deadband
.....LIMIT	[0375]	Setpoint Sum
a.....INPUT 2	[0423]	Setpoint Sum
a.....INPUT 1	[0100]	Deadband
a.....INPUT 0	[0309]	Setpoint Sum
<b>.....PASSWORD</b>		
.....ENTER PASSWORD	[0120]	Menus
a.....CHANGE PASSWORD	[0121]	Menus
<b>.....ALARM STATUS</b>		
.....LAST ALARM	[0528]	Alarms
a.....HEALTH WORD	[0115]	Alarms
a.....HEALTH STORE	[0116]	Alarms
.....THERMISTOR STATE	[0337]	Alarms
.....SPEED FBK STATE	[0472]	Alarms
a.....STALL TRIP	[0112]	Alarms
.....REMOTE TRIP	[0542]	Alarms
<b>.....MENUS</b>		
.....VIEW LEVEL	[0037]	Menus
a.....LANGUAGE	[0304]	Menus
<b>.....SERIAL LINKS</b>		
.....TEC OPTION		
.....TEC OPTION TYPE	[0500]	Tec Option
.....TEC OPTION IN 1	[0501]	Tec Option
.....TEC OPTION IN 2	[0502]	Tec Option
.....TEC OPTION IN 3	[0503]	Tec Option
.....TEC OPTION IN 4	[0504]	Tec Option
.....TEC OPTION IN 5	[0505]	Tec Option
.....TEC OPTION FAULT	[0506]	Tec Option
.....TEC OPTION VER	[0507]	Tec Option
.....TEC OPTION OUT 1	[0508]	Tec Option
.....TEC OPTION OUT 2	[0509]	Tec Option
.....SYSTEM PORT (P3)		

.....P3 SETUP		
.....MODE	[0130]	Comms Port
.....5703 IN		
.....SETPT. RATIO	[0132]	5703 In
.....SETPT. SIGN	[0133]	5703 In
.....RAW INPUT	[0187]	5703 In
.....SCALED INPUT	[0189]	5703 In
.....BISYNCH SUPPORT		
.....GROUP ID (GID)	[0329]	Comms Port
.....UNIT ID (UID)	[0330]	Comms Port
.....ERROR REPORT	[0332]	Comms Port
.....BAUD RATE	[0198]	Comms Port
a.....DUMP CHANGED	[1169]	Configure Drive
.....DUMP MMI (TX)	[1167]	Configure Drive
.....UDP XFER (RX)	[1171]	Configure Drive
.....UDP XFER (TX)	[1170]	Configure Drive
.....VERSION NUMBER	[0155]	Drive Info
.....PNO CONFIG		
.....PNO 112	[0312]	PNO Config
.....PNO 113	[0313]	PNO Config
.....PNO 114	[0314]	PNO Config
.....PNO 115	[0315]	PNO Config
.....PNO 116	[0316]	PNO Config
.....PNO 117	[0317]	PNO Config
.....PNO 118	[0318]	PNO Config
.....PNO 119	[0319]	PNO Config
.....PNO 120	[0320]	PNO Config
.....PNO 121	[0321]	PNO Config
.....PNO 122	[0322]	PNO Config
.....PNO 123	[0323]	PNO Config
.....PNO 124	[0324]	PNO Config
.....PNO 125	[0325]	PNO Config
.....PNO 126	[0326]	PNO Config
.....PNO 127	[0327]	PNO Config
..... <b>SYSTEM</b>		
a.....CONFIGURE I/O		

## C-48 Parameter Specification Tables

.....CONFIGURE ENABLE	[0039]	Configure Drive
.....ANALOG INPUTS		
.....ANIN 1 (A2)		
.....CALIBRATION	[0230]	Analog Input
.....MAX VALUE	[0231]	Analog Input
.....MIN VALUE	[0232]	Analog Input
.....DESTINATION TAG	[0246]	Link
.....ANIN 2 (A3)		
.....CALIBRATION	[0233]	Analog Input
.....MAX VALUE	[0234]	Analog Input
.....MIN VALUE	[0235]	Analog Input
.....OUTPUT	[0493]	Analog Input
.....ANIN 3 (A4)		
.....CALIBRATION	[0236]	Analog Input
.....MAX VALUE	[0237]	Analog Input
.....MIN VALUE	[0238]	Analog Input
.....DESTINATION TAG	[0249]	Link
.....ANIN 4 (A5)		
.....CALIBRATION	[0239]	Analog Input
.....MAX VALUE	[0240]	Analog Input
.....MIN VALUE	[0241]	Analog Input
.....DESTINATION TAG	[0250]	Link
.....ANIN 5 (A6)		
.....CALIBRATION	[0242]	Analog Input
.....MAX VALUE	[0243]	Analog Input
.....MIN VALUE	[0244]	Analog Input
.....DESTINATION TAG	[0247]	Link
.....ANALOG OUTPUTS		
.....ANOUT 1 (A7)		
.....% TO GET 10V	[0245]	Analog Output
.....MODULUS	[0362]	Analog Output
.....OFFSET	[0464]	Analog Output
.....SOURCE TAG	[0251]	Link
.....ANOUT 2 (A8)		
.....% TO GET 10V	[0248]	Analog Output
.....MODULUS	[0363]	Analog Output

.....OFFSET	[0465]	Analog Output
.....SOURCE TAG	[0252]	Link
.....DIGITAL INPUTS		
a.....DIGITAL INPUT C4		
.....DESTINATION TAG	[0494]	Link
a.....DIGITAL INPUT C5		
.....DESTINATION TAG	[0495]	Link
.....DIGIN 1 (C6)		
.....VALUE FOR TRUE	[0103]	Digital Input
.....VALUE FOR FALSE	[0104]	Digital Input
.....DESTINATION TAG	[0102]	Link
.....DIGIN 2 (C7)		
.....VALUE FOR TRUE	[0106]	Digital Input
.....VALUE FOR FALSE	[0107]	Digital Input
.....DESTINATION TAG	[0105]	Link
.....DIGIN 3 (C8)		
.....VALUE FOR TRUE	[0109]	Digital Input
.....VALUE FOR FALSE	[0110]	Digital Input
.....DESTINATION TAG	[0108]	Link
.....DIGITAL OUTPUTS		
.....DIGOUT 1 (B5)		
.....THRESHOLD (>)	[0195]	Digital Output
.....MODULUS	[0043]	Digital Output
.....SOURCE TAG	[0097]	Link
.....INVERTED	[0359]	Digital Output
.....DIGOUT 2 (B6)		
.....THRESHOLD (>)	[0196]	Digital Output
.....MODULUS	[0044]	Digital Output
.....SOURCE TAG	[0098]	Link
.....INVERTED	[0360]	Digital Output
.....DIGOUT 3 (B7)		
.....THRESHOLD (>)	[0197]	Digital Output
.....MODULUS	[0045]	Digital Output
.....SOURCE TAG	[0099]	Link
.....INVERTED	[0361]	Digital Output
.....CONFIGURE 5703		



## C-50 Parameter Specification Tables

.....SOURCE TAG	[0134]	Link
.....DESTINATION TAG	[0135]	Link
.....BLOCK DIAGRAM		
.....RAMP O/P DEST	[0293]	Link
.....SPT SUM 1 DEST	[0294]	Link
.....PID O/P DEST	[0400]	Link
.....DIAMETER	[0431]	Link
.....TAPER	[0442]	Link
.....SETPOINT SUM 2	[0450]	Link
.....POS. I CLAMP	[0435]	Link
.....NEG. I CLAMP	[0436]	Link
.....TENS+COMP CALC.	[0478]	Link
.....RAISE/LOWER DEST	[0260]	Link
.....PRESET DEST	[0573]	Link
.....SRAMP DEST	[0590]	Link
a.....INTERNAL LINKS		
a.....LINK 1		
.....SOURCE TAG	[0364]	Link
.....DESTINATION TAG	[0365]	Link
a.....LINK 2		
.....SOURCE TAG	[0366]	Link
.....DESTINATION TAG	[0367]	Link
a.....LINK 3		
.....SOURCE TAG	[0368]	Link
.....DESTINATION TAG	[0369]	Link
a.....LINK 4		
.....SOURCE TAG	[0370]	Link
.....DESTINATION TAG	[0371]	Link
a.....LINK 5		
.....SOURCE TAG	[0454]	Link
.....DESTINATION TAG	[0455]	Link
a.....LINK 6		
.....SOURCE TAG	[0456]	Link
.....DESTINATION TAG	[0457]	Link
a.....LINK 7		
.....SOURCE TAG	[0458]	Link

.....DESTINATION TAG	[0459]	Link
a.....LINK 8		
.....SOURCE TAG	[0460]	Link
.....DESTINATION TAG	[0461]	Link
a.....LINK 9		
.....SOURCE TAG	[0467]	Link
.....DESTINATION TAG	[0468]	Link
a.....LINK 10		
.....SOURCE TAG	[0469]	Link
.....DESTINATION TAG	[0470]	Link
a.....LINK 11		
.....SOURCE TAG	[0390]	Link
.....DESTINATION TAG	[0391]	Link
.....ADVANCED	[0392]	Advanced
.....MODE	[0393]	Advanced
.....AUX.SOURCE	[0394]	Link
a.....LINK 12		
.....SOURCE TAG	[0395]	Link
.....DESTINATION TAG	[0396]	Link
.....ADVANCED	[0397]	Advanced
.....MODE	[0398]	Advanced
.....AUX.SOURCE	[0399]	Link
a.....miniLINK		
a.....VALUE 1	[0339]	Minilink
a.....VALUE 2	[0340]	Minilink
a.....VALUE 3	[0341]	Minilink
a.....VALUE 4	[0342]	Minilink
a.....VALUE 5	[0343]	Minilink
a.....VALUE 6	[0344]	Minilink
a.....VALUE 7	[0345]	Minilink
a.....VALUE 8	[0379]	Minilink
a.....VALUE 9	[0380]	Minilink
a.....VALUE 10	[0381]	Minilink
a.....VALUE 11	[0382]	Minilink
a.....VALUE 12	[0383]	Minilink
a.....VALUE 13	[0384]	Minilink

## C-52 Parameter Specification Tables

a.....VALUE 14	[0385]	Minilink
a.....LOGIC 1	[0346]	Minilink
a.....LOGIC 2	[0347]	Minilink
a.....LOGIC 3	[0348]	Minilink
a.....LOGIC 4	[0349]	Minilink
a.....LOGIC 5	[0350]	Minilink
a.....LOGIC 6	[0351]	Minilink
a.....LOGIC 7	[0352]	Minilink
a.....LOGIC 8	[0353]	Minilink
.....SAVE TO OP	[0624]	Configure Drive
.....LOAD FROM OP	[0625]	Configure Drive
.....SPEED DEMAND	[0089]	Speed Loop
.....SPEED FEEDBACK	[0207]	Feedbacks
.....CURRENT DEMAND	[0299]	Current Loop
.....CURRENT FEEDBACK	[0298]	Feedbacks
.....PHASE ANGLE @ E	[1174]	Current Loop
a.....ADDITIONAL DEM	[0030]	Current Loop
..... <b>PARAMETER SAVE</b>	<b>[0354]</b>	<b>Configure Drive</b>
..... <b>CONFIGURE DRIVE</b>		
.....CONFIGURE ENABLE	[0039]	Configure Drive
.....NOM MOTOR VOLTS	[0521]	Configure Drive
.....ARMATURE CURRENT	[0523]	Configure Drive
.....FIELD CURRENT	[0524]	Configure Drive
.....FLD.CTRL MODE	[0209]	Field Control
.....FLD.VOLTS RATIO	[0210]	Field Control
.....MAIN CURR. LIMIT	[0421]	Current Loop
.....AUTOTUNE	[0018]	Auto-Tune
.....SPEED FBK SELECT	[0047]	Speed Loop
.....ENCODER LINES	[0024]	Encoder
.....ENCODER RPM	[0022]	Encoder
.....ENCODER SIGN	[0049]	Encoder
.....SPD.INT.TIME	[0013]	Speed Loop
.....SPD.PROP.GAIN	[0014]	Speed Loop

## Appendix D **Programming**

This Appendix provides an introduction to programming the drive. It describes the function blocks and parameters available in DSE Lite. The FUNCTION BLOCKS menu on the MMI provides access to these programming tool menu structures.

### Programming Your Application

- Programming with Block Diagrams

### Function Block Descriptions

### The Default Application

- Block Diagrams



# Programming Your Application

## Programming with Block Diagrams

We recommend that you use a suitable programming tool (such as “DSELite” which is Parker SSD Drives’ block programming software) to program the Drive for specific applications. It is however possible to use the Keypad.

**NOTE** The Menus on the MMI contain parameters that don't necessarily reside in similarly-named function blocks in our Configuration Tool. To locate the function block for a parameter when using the MMI, hold the "M" key down when editing the parameter. This will display the Tag number. You can find the details for every Tag in this Appendix: Parameter Specification Tables. Alternatively, the Parameter Table in Appendix C: "Parameter Specifications" provides a quick reference from the MMI list to the associated function block.

The Drive is supplied with a basic set-up which can be used as a starting point for application-specific programming. This programming could simply involve the inputting of parameter values, or it may require the making or breaking of programmable links, which is a feature of this unit.

Block diagram programming provides a visual method of planning the software to suit your application. The basic block diagram is provided at the end of this Appendix and shows the software connections consisting of *function blocks* and *links*:

- Each function block contains the parameters required for setting-up a particular processing feature. Sometimes more than one function block is provided for a feature, i.e. for multiple digital inputs.
- Software links are used to connect the function blocks. Each link transfers the value of an output parameter to an input parameter of another (or the same) function block.

Each individual block is a processing feature: it takes the input parameter, processes the information, and makes the result available as one or more output parameters.

## Modifying a Block Diagram

### Operating and Configuration Modes

There are two modes of operation used while modifying a block diagram: *Operating* and *Configuration* modes.

The CONFIGURE ENABLE command is used to toggle between these two modes of operation.

DEFAULT

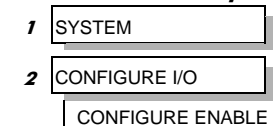
#### ***Operating Mode (CONFIGURE ENABLE = DISABLED)***

In Operating mode you can change parameter values. The Drive can be running or stopped. Note that some parameters can only be changed when the Drive is stopped. It is not possible to modify the internal links when the Drive is in Operating mode.

#### ***Configuration Mode (CONFIGURE ENABLE = ENABLED)***

In the configuration mode you can modify connections between the function blocks in the drive. You can also change parameter values, as above. The Drive cannot run in this mode. Output values are not updated.

#### ***MMI Menu Map***



### Making and Breaking Function Block Connections

Links can be changed, added or deleted from a block diagram whilst in the Configuration mode. There are 80 general-purpose links available, each has its own identification number (“link” number). You make a link by setting the link’s “source” and “destination” tags to be the two parameter tag numbers to be linked. The outputs of function blocks are not updated whilst in this mode.

**NOTE** Links 1 to 50 are pre-connected between certain blocks and form the connections shown in the Default Block Diagram. Any of these links can be re-used elsewhere in the block diagram.

The functions of the special links in previous software versions, (LINK 11 and LINK 12), are replaced by the ADVANCED 1 AND ADVANCED 2 function blocks.

In previous software versions, certain links were single-ended "special links". This is no longer the case. All links can now be re-used anywhere in the block diagram.

### Programming Rules

The following rules apply when programming:

#### *Operating Mode (CONFIGURE ENABLE = DISABLED)*

- Function block output parameter values cannot be changed (because they are a result of the function block’s processing)
- Function block input parameter values that receive their values from a link cannot be changed (as the link will overwrite the value when the Drive is running).

#### *Configuration Mode (CONFIGURE ENABLE = ENABLED)*

- A link’s destination tag must be set to an input parameter (only one link per input parameter).
- A link’s source tag may be set to any parameter. Both input and output parameters can be used as a source.
- Disable a link/function block by setting the “destination” and “source” tag to zero.
- To mark a link as a feedback link, set the source to the negative value of the tag to be connected. Feedback links are ignored when the function block execution order is determined.

### Execution Rules

The complete block diagram is executed every 5ms, with individual control blocks executing within 1ms. Just before a function block is executed, all the links that have that block as their destination are executed, thereby copying new values in to the block’s parameter inputs. The input parameters are then processed to produce a new set of output parameters. The execution order of the blocks is automatically arranged for minimal delay.

The output value transferred by a link on execution is clamped to be between the maximum and minimum value for its destination input parameter.

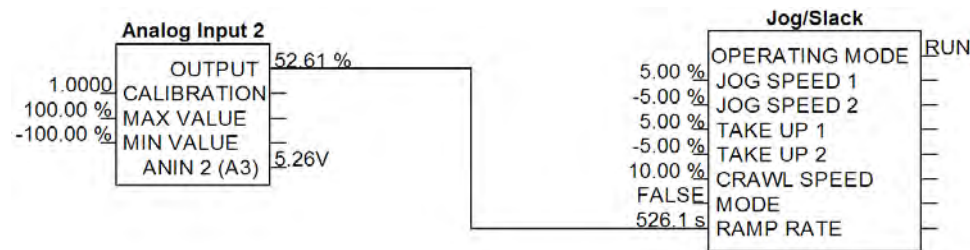
1	FUNCTION BLOCKS
2	MISCELLANEOUS
3	CONFIGURE DRIVE
	AUTOMATIC SAVE
	DUMP BLOCKS
	DUMP TRACE
	UDP USE OP PORT
	EMULATE 590P
	DEBOUNCE DIGIN

The setting of the EMULATE 590P parameter (tag 162) in the CONFIGURE DRIVE function block affects the time constants of the PID block and the linking of parameters in the function block diagram:

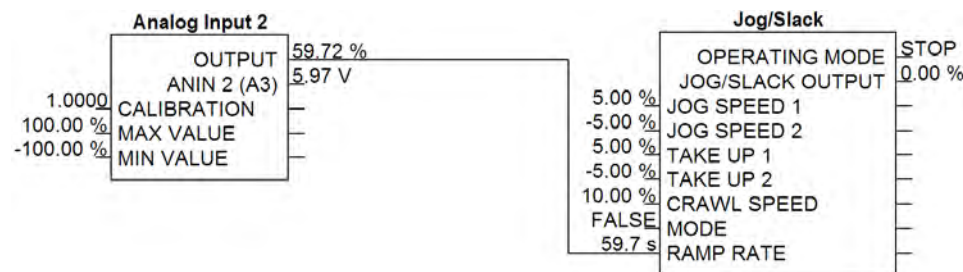
- **When non-zero** the drive emulates the functionality of links in earlier firmware versions of the 590P, (firmware Versions 5.x and 7.x)
- **When zero (0x0000)** the behaviour changes so that the value is transferred, preserving the decimal place, (firmware Version 8.x and onwards).

Refer to "Compatibility with Earlier Versions of Firmware", page D-7, for more information.

To maintain compatibility, the new firmware emulates the functionality and behavior of links in earlier firmware versions by defaulting the EMULATE 590P parameter to 0x0001 (non-zero).



**Figure 1 Operation of links (EMULATE 590P = non-zero : firmware Versions 5.x, 7.x, 8.x and onwards)**



**Figure 2 Operation of links (EMULATE 590P = zero : firmware Version 8.x and onwards)**

The operation of a link is determined by the number of decimal places of each parameter. Previous firmware versions ignored the decimal place when linking two parameters. For example, linking Analog Input 2 to the Jog Ramp rate gave a Ramp Rate of 526.1s for an input value of 52.61%. Compare the Figure above.

An additional enhancement is that all values are now held to over 4 decimal places of precision. This is also true of values transferred via links. In the above example, although the Jog Ramp Rate is shown as 59.7s, internally the value will match that of the output of Analog Input 2, to over 4 decimal places.



## Saving Your Modifications

Ensure that CONFIGURE ENABLE = DISABLED before performing a PARAMETER SAVE.

If AUTOMATIC SAVE is set TRUE then changes made via the Operator Station are automatically saved.

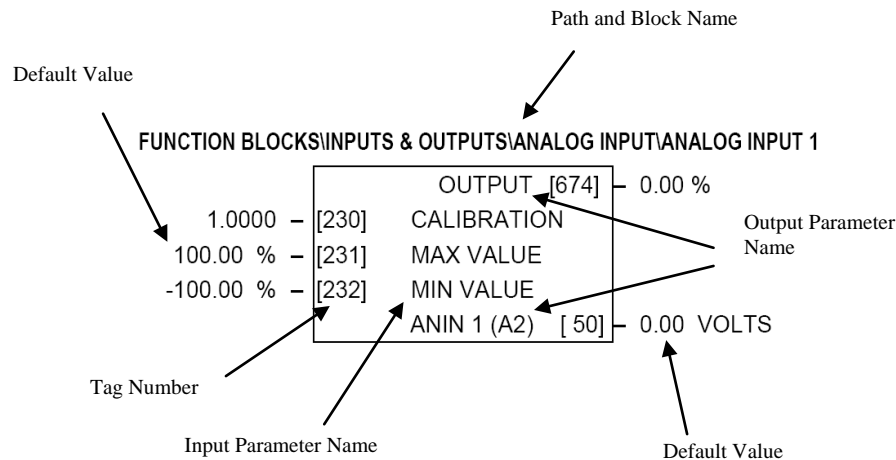
If parameter values or links have been modified, the new settings must be saved. The Drive will then retain the new settings during power-down. Refer to Chapter 6: "The Keypad" - Saving Your Application.

## Understanding the Function Block Description

The following function blocks show the parameter information necessary for programming the Drive. Input parameters are shown on the left hand side, and output parameters are shown on the right hand side of the block.

<b>Default Value</b>	The default value of the unmodified factory set-up
<b>Input/Output Parameter Name</b>	The name shown on DSELite
<b>Tag Number</b>	Unique identification used for linking and communications

Decimal Places - some parameters are held in memory with two decimal places but are displayed with one decimal place. These parameters are indicated in the Parameter Description tables. The Range parameter highlights these with a " (h) " suffix.



**Figure D-3 Function Block Parameter Information**

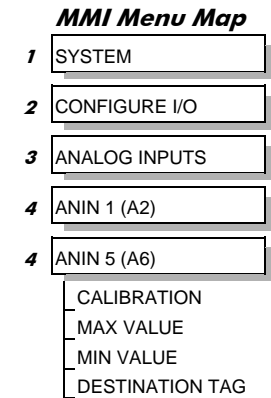
## MMI Menu Maps

The function block descriptions include an easy-find menu showing the menu levels and titles encountered to find the appropriate menu title, and the parameters contained in the menu(s).

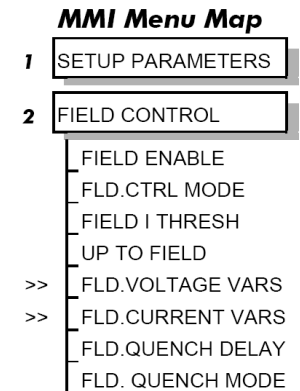
The Menu Maps are shown as if the view level is STANDARD.

Where there is more than one sub-menu, i.e. ANALOG INPUTS as illustrated, the parameters shown will be for the last sub-menu. In many cases, these parameters will reflect the name and number of the last sub-menu.

MMI parameters are named intuitively to make the keypad easier to use, however, they may vary slightly from function block names.



A function block may contain parameters that are contained within more than one MMI menu, for example FIELD CONTROL. In this case, the extra menus are indicated by >> in the MMI Menu Map.



## Function Blocks By Category

The function blocks described in this Appendix are arranged in alphabetical order, however, they are listed below by Category. They each appear as a Menu in the FUNCTION BLOCKS menu. To view the FUNCTION BLOCKS Menu, ADVANCED view level must be selected

### MMI Menu Map

1

<b>Alarms</b>					
ALARM HISTORY	D-16	ALARMS	D-17		
<b>Communications</b>					
5703 IN	D-11	COMMS PORT	D-31	TEC OPTION	D-132
5705 OUT	D-12	miniLINK	D-84		
<b>Inputs &amp; Outputs</b>					
ANALOG INPUTS	D-21	AUX I/O	D-27	DIGITAL OUTPUTS	D-53
ANALOG OUTPUTS	D-23	DIGITAL INPUTS	D-50		
<b>Menus</b>					
MENUS	D-82	OP STATION	D-86		
<b>Miscellaneous</b>					
ADVANCED	D-13	DRIVE INFO	D-56	MULTIPLEXER	D-85
CONFIGURE DRIVE	D-33	LINKS	D-71	VALUE FUNC	D-135
DEMULITPLEXER	D-41	LOGIC FUNC	D-76		
<b>Motor Control</b>					
AUTOTUNE	D-24	ENCODER	D-58	INVERSE TIME	D-72
CALIBRATION	D-28	FEEDBACKS	D-61	PLL	D-93
CURRENT LOOP	D-34	FIELD CONTROL	D-63	SPEED LOOP	D-116
CURRENT PROFILE	D-39	INERTIA COMP	D-70		
<b>Seq &amp; Ref</b>					
JOG/SLACK	D-73	SEQUENCING	D-110	STOP RATES	D-129
RAMPS	D-103	STANDSTILL	D-126		
<b>Setpoint Funcs</b>					
DEADBAND	D-40	PRESET SPEEDS	D-95	SETPOINT SUM	D-113
MIN SPEED	D-83	RAISE/LOWER	D-100	SRAMP	D-123
PID	D-88	SELECT	D-109		
<b>Winder</b>					
DIAMETER CALC	D-42	PROFILED GAIN	D-98	TORQUE CALC	D-134

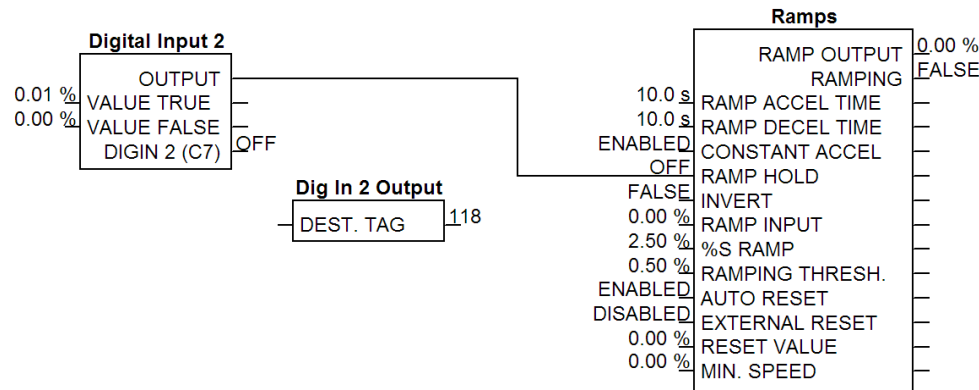
## Compatibility with Earlier Versions of Firmware

Version 8.x and onwards of the 590P is upwardly compatible with earlier firmware versions of the 590P. It will accept and run existing configurations when downloaded via UDP, from DSELite or from a saved copy in the operator station’s memory. These earlier versions of firmware will not however accept a configuration designed for use with Version 8.x firmware and onwards.

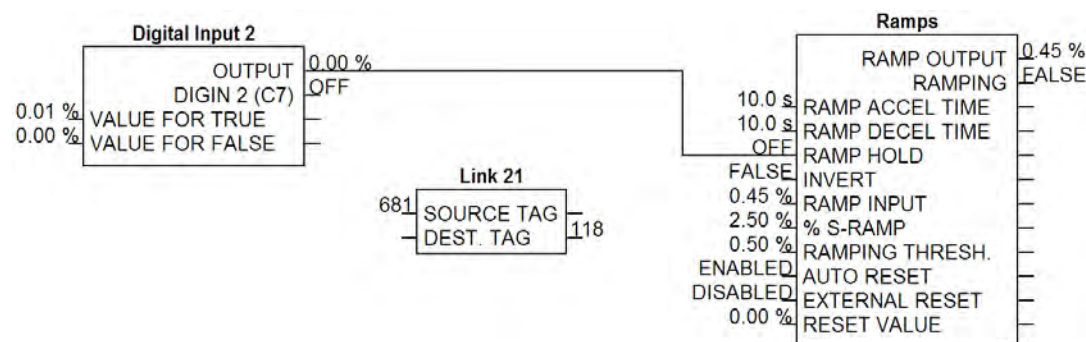
The implementation of the function block diagram destination links and source links is subtly different in version 8.x and onwards. All links have been rationalised to allow connection of any parameter to any input parameter. These enhancements will not interfere with operation of earlier configurations. The enhancements are designed to further improve the flexibility of the function block diagram.

In general, all “output” links have been replaced with the combination of a new output parameter and a new general purpose link. Similarly, all “input” links have been replaced with the combination of a new input parameter and a new general purpose link. Where a suitable output or input parameter already existed there was no need to create a new one, (for example, Configure 5703::Scaled Input already existed as a parameter).

As an illustration, consider the operation of Digital Input 2. Prior to Version 8.1 the output value was not available as an accessible parameter. It could be wired to an input parameter using its dedicated destination tag. By default it was connected to tag 118, RAMP HOLD.



In the revised implementation, the output value is available as a new parameter, OUTPUT. This may be connected to any input parameter using any general purpose link. By default, Link 21 is used to connect OUTPUT (tag 681) to RAMP HOLD (tag 118).



The following tables show the new input and output parameters available, and the allocation of links in the default configuration to emulate the behaviour of previous versions of firmware.

### Enhancements to output links

Legacy implementation	
Digin1 (C6)::Destination Tag [102]	→
Digin2 (C7)::Destination Tag [105]	→
Digin3 (C8)::Destination Tag [108]	→
Digital Input C4::Destination Tag [494]	→
Digital Input C5::Destination Tag [495]	→
Configure 5703::Scaled Input [135]	→
Anin 1 (A2)::Destination Tag [246]	→
Anin 3 (A4)::Destination Tag [249]	→
Anin 4 (A5)::Destination Tag [250]	→
Anin 5 (A6)::Destination Tag [247]	→
Raise/Lower Dest [260]	→
Ramp O/P Dest [293]	→
SPT Sum 1 Dest [294]	→
Link 11::Destination Tag [391]	→

Version 8.x and onwards.x implementation		
Digital Input 1::Output [680]	→	[635] Link 20 [102] →
Digital Input 2::Output [681]	→	[636] Link 21 [105] →
Digital Input 3::Output [682]	→	[637] Link 22 [108] →
Digital Input 4::Digital Input C4 [69]	→	[652] Link 37 [494] →
Digital Input 5::Digital Input C5 [70]	→	[653] Link 38 [495] →
5703 In::Scaled Input [189]	→	[662] Link 45 [135] →
Analog Input 1::Output [674]	→	[638] Link 23 [246] →
Analog Input 3::Output [675]	→	[639] Link 24 [249] →
Analog Input 4::Output [676]	→	[640] Link 25 [250] →
Analog Input 5::Output [677]	→	[641] Link 26 [247] →
Raise/Lower::Output [264]	→	[642] Link 27 [260] →
Ramps::Ramp Output [85]	→	[643] Link 28 [293] →
Setpoint Sum 1::Spt Sum Output [86]	→	[644] Link 29 [294] →
Advanced 1::Output [712]	→	[658] Link 43 [391] →

Legacy implementation

Link 12::Destination Tag [396]	→
PID O/P Dest [400]	→
Diameter [431]	→
Pos I Clamp [435]	→
Neg. I Clamp [436]	→
Taper [442]	→
Setpoint Sum 2 [450]	→
Tens + Comp Calc. [478]	→
Preset Dest [573]	→
Sramp Dest [590]	→

Version 8.x and onwards.x implementation

Advanced 2::Output [713]	→	[660] Link 44 [396]	→
PID::PID Output [417]	→	[645] Link 30 [400]	→
Diameter Calc.::Diameter [427]	→	[646] Link 31 [431]	→
Torque Calc.::Pos. I Clamp [707]	→	[647] Link 32 [435]	→
Torque Calc.::Neg. I Clamp [708]	→	[648] Link 33 [436]	→
Diameter Calc.::Tot.Tens Demand [441]	→	[649] Link 34 [442]	→
Setpoint Sum 2::Spt Sum Output [451]	→	[650] Link 35 [450]	→
Diameter Calc.::Output [706]	→	[651] Link 36 [478]	→
Preset Speeds::Preset O/P [572]	→	[654] Link 39 [573]	→
Sramp::Sramp Output [589]	→	[655] Link 40 [590]	→

**Enhancements to input links**

Legacy implementation

→ [097] Digout 1 (B5)::Source Tag
→ [098] Digout 2 (B6)::Source Tag
→ [099] Digout 3 (B7)::Source Tag
→ [134] Configure 5703::Source Tag
→ [251] Anout 1 (A7)::Source Tag
→ [252] Anout 2 (A8)::Source Tag
→ [306] Standstill::Source Tag
→ [390] Link 11::Source Tag
→ [394] Link 11::Aux.Source
→ [395] Link 12::Source Tag
→ [399] Link 12::Aux.Source

Version 8.x and onwards.x implementation

→ [097] Link 13 [629]	→	[683] Digital Output 1::Input
→ [098] Link 14 [630]	→	[684] Digital Output 2::Input
→ [099] Link 15 [631]	→	[685] Digital Output 3::Input
→ [134] Link 16 [1190]	→	[714] 5703 Out::Input
→ [251] Link 17 [632]	→	[678] Analog Output 1::Input
→ [252] Link 18 [633]	→	[679] Analog Output 2::Input
→ [306] Link 19 [634]	→	[699] Standstill::Input
→ [390] Link 11 [1188]	→	[686] Advanced 1::Input 1
→ [394] Link 41 [656]	→	[687] Advanced 1::Input 2
→ [395] Link 12 [1189]	→	[688] Advanced 2::Input 1
→ [399] Link 42 [657]	→	[689] Advanced 2::Input 2

### ***Simplification of function blocks***

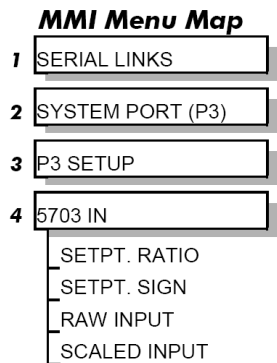
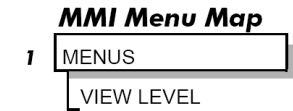
Some function blocks from previous versions of firmware have been re-arranged to clarify the functionality of each block. The changes are:

- SETPOINT SUM 1:      The Deadband function has been extracted into a new DEADBAND function block.
- 5703:                    This has been split into function blocks 5703 IN and 5703 OUT to improve function block execution order.
- AUX IO:                 This has been split into a new SEQUENCING function block and a smaller AUX I/O block.
- PID:                     The Gain Profile function has been extracted into a new PROFILED GAIN function block.
- RAMPS:                 The Minimum Speed function has been extracted into a new MIN SPEED function block.

In addition, the old Diameter Calc, Taper Calc and Tension & Comp blocks have been combined into a single block called Diameter Calc due to the close ties between these blocks.

# Function Block Descriptions

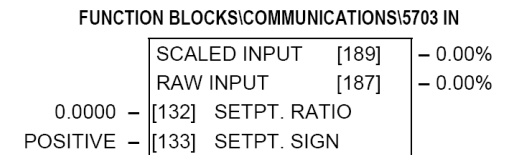
**NOTE** Remember to select the correct mode, Setup or Configuration, whilst editing. Refer to “Modifying a Block Diagram”, page D-1. To view the FUNCTION BLOCKS Menu, ADVANCED view level must be selected.



## 5703 IN

This function block contains the parameters for scaling the setpoint that are received via the P3 comms port using the 5703 setpoint repeater protocol.

In the default configuration, the output of this block (SCALED INPUT) is added to analog inputs 1, 2 and 3 to form the setpoint.

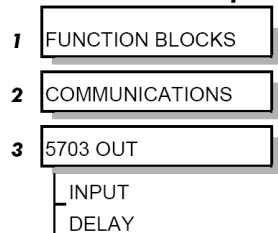


## 5703 IN

Parameter	Tag	Range
<b>SETPT. RATIO</b> Input scaler.	<b>132</b>	<b>-3.0000 to 3.0000</b>
<b>SETPT. SIGN</b> Input sign.	<b>133</b>	<b>NEGATIVE/ POSITIVE</b>
<b>SCALED INPUT</b> The scaled value received by the 5703 unit. This value is updated upon reception of a new message. If the drive is in Slave mode and no new messages have arrived, a 5703 RCV ERROR will occur. Note: in software versions prior to 5.17, this input is not updated when in Master mode.	<b>189</b>	<b>— .xx %</b>
<b>RAW INPUT</b> The unscaled value received via the P3 port.	<b>187</b>	<b>— .xx %</b>



**MMI Menu Map**



## 5703 OUT

This function block is used to define the value that is sent via the P3 port when the selected protocol is “5703 MASTER” or “5703 SLAVE”.

FUNCTION BLOCKS\COMMUNICATIONS\5703 OUT

0.00 % - [714] INPUT  
0 ms - [897] DELAY

- In 5703 MASTER mode, the INPUT value is transmitted with a minimum period of 5ms. This period may be increased using the DELAY parameter. Note that the delay is the time from the start of one transmission to the start of the next transmission. If the selected baud rate is low then the time to transmit the data may be greater than the delay time, in which case the delay parameter has no effect.
- In 5703 SLAVE mode, the INPUT value is transmitted every time a value is received. The DELAY parameter is ignored in this mode.

### 5703 OUT

Parameter	Tag	Range
<b>INPUT</b>	<b>714</b>	<b>-300.00 to 300.00 %</b>
The value that will be sent via the P3 port when the P3 MODE is either “5703 MASTER” or “5703 SLAVE”.		
<b>DELAY</b>	<b>897</b>	<b>0 to 1000 ms</b>
A delay parameter that may be used when in 5703 MASTER mode to increase the time between successive transmissions of the 5703 setpoint value.		

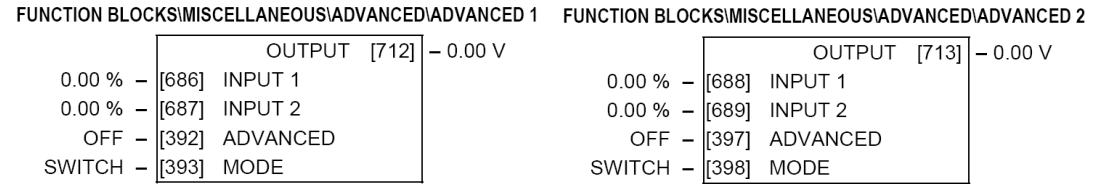
**MMI Menu Map**

- 1 SYSTEM
- 2 CONFIGURE I/O
- 3 INTERNAL LINKS
- 4 LINK 11
- 4 LINK 12
  - SOURCE TAG
  - DESTINATION TAG
  - ADVANCED
  - MODE
  - AUX. SOURCE

**ADVANCED**

These two blocks perform some simple functions. They are compatible with the special Link 11 and Link12 used in earlier versions of this product.

For new configurations, consider using the new VALUE and LOGIC function blocks.



**ADVANCED**

Parameter	Tag	Range
<b>INPUT 1</b>	<b>686, 688</b>	<b>-32768.00 to 32768.00 %</b>
General purpose input.		
<b>INPUT 2</b>	<b>687, 689</b>	<b>-32768.00 to 32768.00 %</b>
General purpose input.		
<b>ADVANCED</b>	<b>392, 397</b>	<b>OFF/ON</b>
Controls the OUTPUT parameter. When OFF, OUTPUT is the same as INPUT 1. When ON, OUTPUT is the result of the function selected by MODE.		
<b>MODE</b>	<b>393, 398</b>	<b>See below</b>
This determines which operation is performed on the INPUT 1 and INPUT 2. It can be combined with ADVANCED to dynamically switch the OUTPUT between INPUT 1 and the result of the selected function. The functionality of the various MODE selections are shown in the table.		
0 : SWITCH 1 : INVERTER 2 : AND (logic) 3 : OR (boolean) 4 : SIGN CHANGER 5 : MODULUS 6 : COMPARATOR		
<b>OUTPUT</b>	<b>712, 713</b>	<b>— .xx V</b>
Result of the selected function on the inputs.		

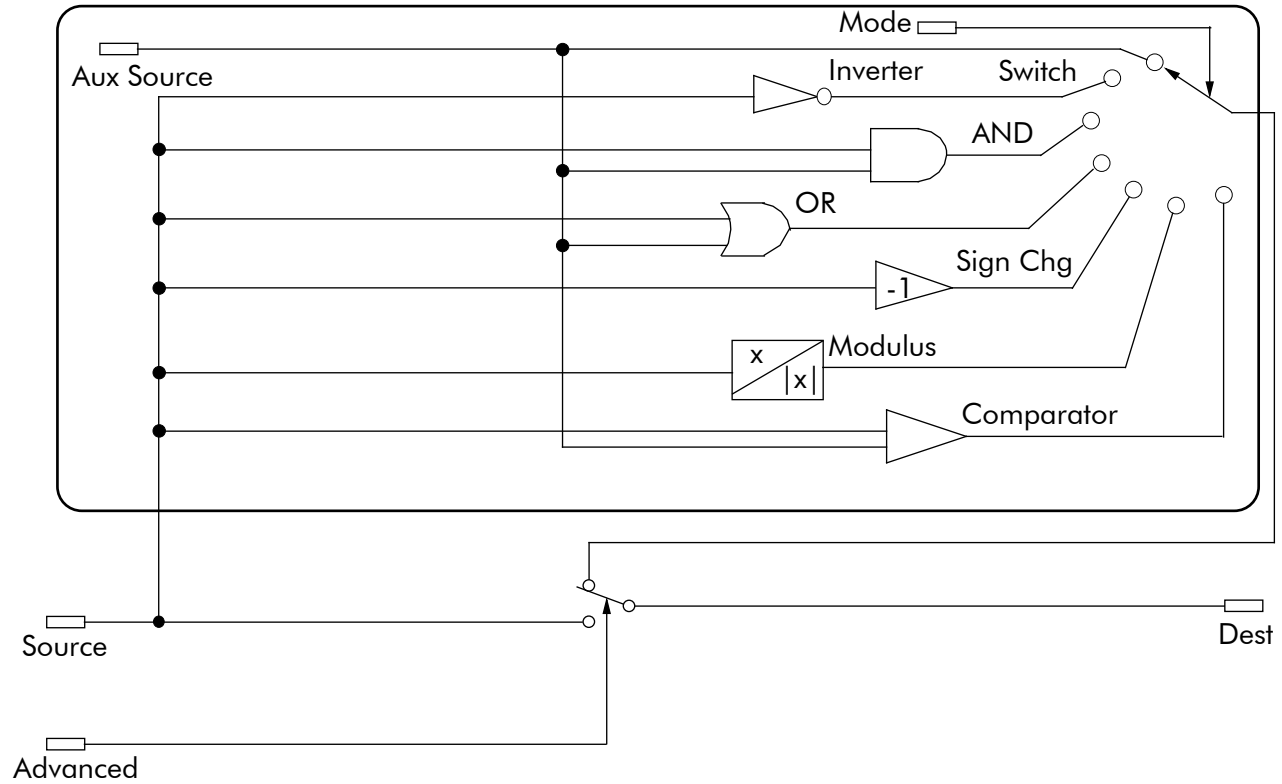
## Functional Description

MODE	Description
<b>SWITCH</b> - switches the signal source between auxiliary and source analog or logic tags	If ADVANCED = OFF OUTPUT = SOURCE If ADVANCED = ON OUTPUT = INPUT 2
<b>INVERTER</b> - inverts the source logic signal	If ADVANCED = OFF OUTPUT = INPUT 1 If ADVANCED = ON OUTPUT = Logic Inversion of INPUT 1
<b>AND</b> - gives AND-ed result of source logic signal and an auxiliary source logic signal	If ADVANCED = OFF OUTPUT = INPUT 1 If ADVANCED = ON OUTPUT = INPUT 1 AND INPUT 2
<b>OR</b> - gives OR-ed result of source logic signal and an auxiliary source logic signal	If ADVANCED = OFF OUTPUT = INPUT 1 If ADVANCED = ON OUTPUT = INPUT 1 OR INPUT 2
<b>SIGN CHANGER</b> - reverses the sign of the source logic signal	If ADVANCED = OFF OUTPUT = INPUT 1 If ADVANCED = ON OUTPUT = Value sign change of INPUT 1
<b>MODULUS</b> - produces the modulus of the source logic signal	If ADVANCED = OFF OUTPUT = INPUT 1 If ADVANCED = ON OUTPUT = Modulus of INPUT 1
<b>COMPARATOR</b> - changes destination logic signal to TRUE when source analog signal is greater than auxiliary analog signal	If ADVANCED = OFF OUTPUT = INPUT 1 If ADVANCED = ON If INPUT 1 ≤ INPUT 2 OUTPUT = 0 If INPUT 1 > INPUT 2 OUTPUT = 1

## Functional Description

The following diagram shows the internal schematic for a special link.

ADVANCED 1 & ADVANCED 2 (Link 11 & Link 12)



**MMI Menu Map**

- 1 FUNCTION BLOCKS
- 2 ALARMS
- 3 ALARM HISTORY
  - ALARM 1 NEWEST
  - ALARM 2
  - ALARM 3
  - ALARM 4
  - ALARM 5
  - ALARM 6
  - ALARM 7
  - ALARM 8
  - ALARM 9
  - ALARM 10 OLDEST

## ALARM HISTORY

This function block records the last ten alarms. ALARM 1 NEWEST is the most recent alarm and will be the same as the ALARMS::LAST ALARM parameter when an alarm is active.

FUNCTION BLOCKS\ALARMS\ALARM HISTORY

ALARM 1 NEWEST	[1246]	0x0000
ALARM 2	[1247]	0x0000
ALARM 3	[1248]	0x0000
ALARM 4	[1249]	0x0000
ALARM 5	[1250]	0x0000
ALARM 6	[1251]	0x0000
ALARM 7	[1252]	0x0000
ALARM 8	[1253]	0x0000
ALARM 9	[1254]	0x0000
ALARM 10 OLDEST	[1255]	0x0000

### ALARM HISTORY

Parameter	Tag	Range
<b>ALARM 1 NEWEST</b>	<b>1246</b>	<b>0x0000 to 0xFFFF</b>
The hexadecimal value of the most recent alarm. Refer to Chapter 7: "Trips and Fault Finding" - Alarm Messages.		
<b>ALARM 2 - ALARM 9</b>	<b>1247, 1248, 1249, 1250, 1251, 1252, 1253, 1254</b>	<b>0x0000 to 0xFFFF</b>
The second to ninth most recent alarms.		
<b>ALARM 10 OLDEST</b>	<b>1255</b>	<b>0x0000 to 0xFFFF</b>
The tenth most recent alarm.		

# ALARMS

This block allows you to disable certain alarms and leave drive operation un-interrupted if the related fault occurs.

## Caution

Do NOT inhibit any alarms if this might result in danger to personnel or equipment.

FUNCTION BLOCKS\ALARMS\ALARMS		
THERMISTOR STATE	[337]	FALSE
SPEED FBK STATE	[472]	FALSE
HEALTH LED	[122]	FALSE
HEALTH WORD	[115]	0x0000
HEALTH STORE	[116]	0x0000
REMOTE TRIP	[542]	FALSE
STALL TRIP	[112]	FALSE
LAST ALARM	[528]	0x0000
ENABLED	[ 19]	FIELD FAIL
ENABLED	[111]	5703 RCV ERROR
ENABLED	[ 28]	STALL TRIP
TRUE	[305]	TRIP RESET
ENABLED	[ 81]	SPEED FBK ALARM
ENABLED	[ 92]	ENCODER ALARM
ENABLED	[540]	REM TRIP INHIBIT
10.0 s	[541]	REM TRIP DELAY
95.00 %	[263]	STALL THRESHOLD
30.0 s	[224]	STALL TRIP DELAY
50.0 %	[180]	SPDFBK ALM LEVEL

- MMI Menu Map**
- 1 ALARM STATUS
    - LAST ALARM
    - HEALTH WORD
    - HEALTH STORE
    - THERMISTOR STATE
    - SPEED FBK STATE
    - STALL TRIP
    - REMOTE TRIP

- MMI Menu Map**
- 1 SETUP PARAMETERS
  - 2 INHIBIT ALARMS
    - FIELD FAIL
    - 5703 RCV ERROR
    - STALL TRIP
    - TRIP RESET
    - SPEED FBK ALARM
    - ENCODER ALARM
    - REM TRIP INHIBIT

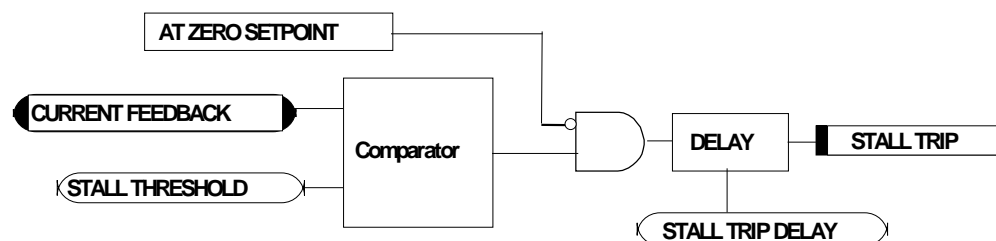
- MMI Menu Map**
- 1 SETUP PARAMETERS
  - 2 CALIBRATION
    - SPDFBK ALM LEVEL
    - STALL THRESHOLD
    - STALL TRIP DELAY
    - REM TRIP DELAY

- MMI Menu Map**
- 1 DIAGNOSTICS
    - HEALTH LED

ALARMS		
Parameter	Tag	Range
<b>FIELD FAIL</b> Inhibits the field fail alarm.	<b>19</b>	<b>ENABLED / INHIBITED</b>
<b>5703 RCV ERROR</b> Inhibits 5703 serial communications receive error. Only active in Slave Mode.	<b>111</b>	<b>ENABLED / INHIBITED</b>
<b>STALL TRIP</b> Inhibits the stall trip alarm from tripping out the contactor. This is useful in applications requiring extended operation at zero speed.	<b>28</b>	<b>ENABLED / INHIBITED</b>
<b>TRIP RESET</b> When FALSE: faults are latched permanently and the HEALTHY output remains inactive, even when toggling the Start/Run input (C3) off/on. Once the drive is stopped the sequencing state remains in the SEQ HOLD state if any fault has been stored. Changing from FALSE to TRUE clears any stored faults. Also, when TRUE: stored faults are cleared whenever a Run signal is given to terminal C3. This feature can be used in applications where you want to reset the faults under your own control, rather than automatically with the Start/Run command.	<b>305</b>	<b>FALSE / TRUE</b>
<b>SPEED FBK ALARM</b> Inhibits the speed feedback alarm.	<b>81</b>	<b>ENABLED / INHIBITED</b>

## ALARMS

Parameter	Tag	Range
<b>ENCODER ALARM</b> Inhibits the encoder option board alarm.	<b>92</b>	<b>ENABLED / INHIBITED</b>
<b>REM TRIP INHIBIT</b> Inhibits the remote trip.	<b>540</b>	<b>ENABLED / INHIBITED</b>
<b>REM TRIP DELAY</b> The delay between the remote trip alarm being activated and the drive tripping.	<b>541</b>	<b>0.1 to 600.0 s</b>
<b>STALL THRESHOLD</b> Stall comparator current feedback threshold level.	<b>263</b>	<b>0.00 to 200.00 %</b>
<b>STALL TRIP DELAY</b> Stall comparator time-out delay before stall output becomes true.	<b>224</b>	<b>0.1 to 600.0 s</b>



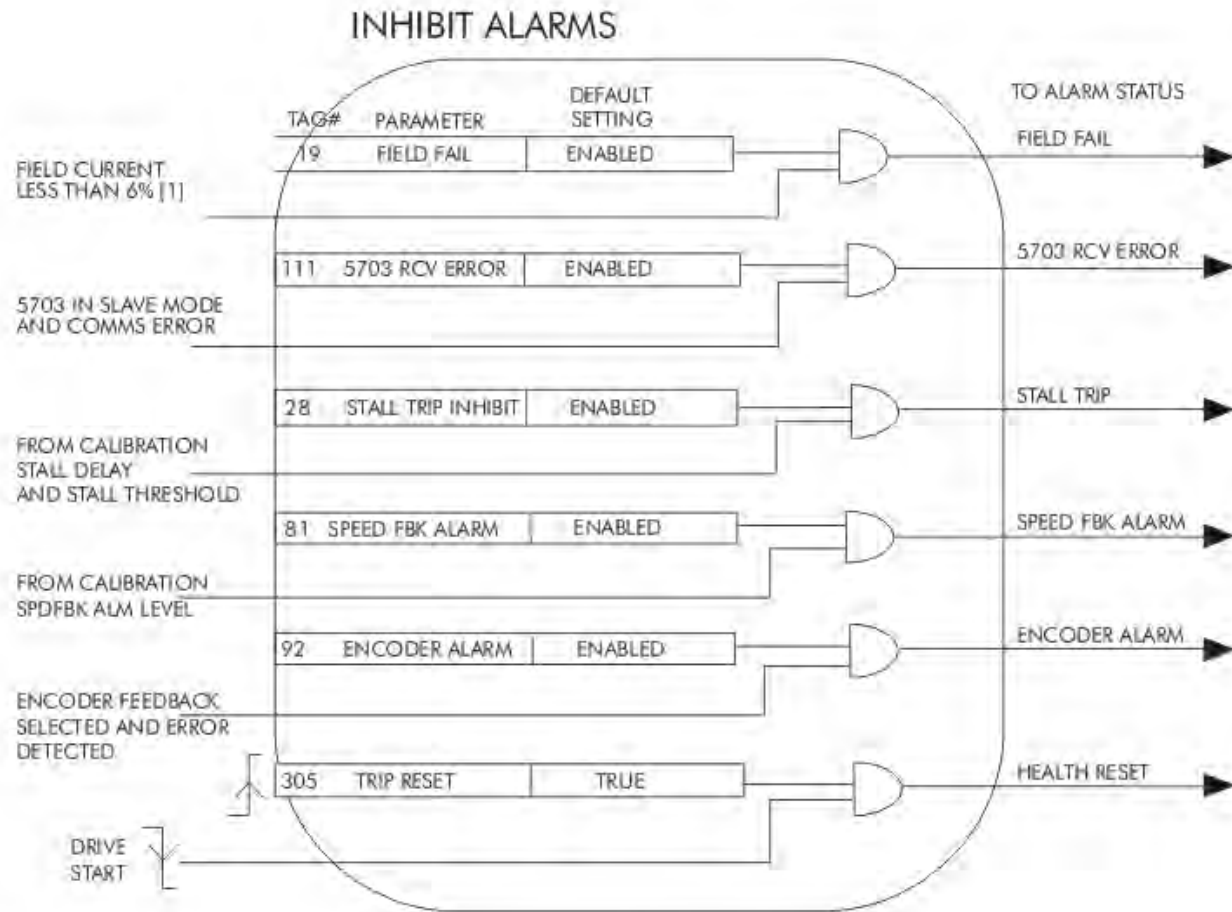
<b>SPDFBK ALM LEVEL</b> The speed feedback alarm compares speed feedback to armature voltage. The alarm level is the threshold which the difference between the two signals should exceed for the alarm to activate.	<b>180</b>	<b>0.0 to 100.0 % (h)</b>
<b>THERMISTOR STATE</b> TRUE if the thermistor input is active, FALSE otherwise.	<b>337</b>	<b>FALSE / TRUE</b>
<b>SPEED FBK STATE</b> A Boolean output that shows the state of the speed feedback alarm. This output is updated even when the alarm is disabled.	<b>472</b>	<b>FALSE / TRUE</b>
<b>HEALTH LED</b> State of Health LED on Keypad.	<b>122</b>	<b>FALSE / TRUE</b>
<b>HEALTH WORD</b> The hexadecimal sum of any alarms present. Refer to Chapter 7: "Trips and Fault Finding" - Alarm Messages.	<b>115</b>	<b>0x0000 to 0xFFFF</b>
<b>HEALTH STORE</b> The hexadecimal value of the first (or only) alarm. Refer to Chapter 7: "Trips and Fault Finding" - Alarm Messages.	<b>116</b>	<b>0x0000 to 0xFFFF</b>
<b>REMOTE TRIP</b> The state of Remote Trip.	<b>542</b>	<b>FALSE / TRUE</b>

**ALARMS**

Parameter	Tag	Range
<b>STALL TRIP</b>	<b>112</b>	<b>FALSE / TRUE</b>
Armature current is above STALL THRESHOLD and AT ZERO SPEED but <u>not</u> AT ZERO SETPOINT.		
<b>LAST ALARM</b>	<b>528</b>	<b>0x0000 to 0xFFFF</b>
The hexadecimal value of the last (or only) alarm. Refer to Chapter 7: “Trips and Fault Finding” - Alarm Messages.		
0x0000 : NO ACTIVE ALARMS		
0x0001 : OVER SPEED		
0x0002 : MISSING PULSE		
0x0004 : FIELD OVER I		
0x0008 : HEATSINK TRIP		
0x0010 : THERMISTOR		
0x0020 : OVER VOLTS (VA)		
0x0040 : SPD FEEDBACK		
0x0080 : ENCODER FAILED		
0x0100 : FIELD FAILED		
0x0200 : 3 PHASE FAILED		
0x0400 : PHASE LOCK		
0x0800 : 5703 RCV ERROR		
0x1000 : STALL TRIP		
0x2000 : OVER I TRIP		
0x8000 : ACCTS FAILED		
0xF001 : AUTOTUNE ERROR		
0xF002 : AUTOTUNE ABORTED		
0xF003 : SEQ PRE READY		
0xF004 : CONTACTOR DELAY		
0xF005 : EXTERNAL TRIP		
0xF006 : REMOTE TRIP		
0xF007 : ENABLE LOW		
0xF009 : SEQUENCING		
0xF010 : COMMS TIMEOUT		
0xF200 : CONFIG ENABLED		
0xF300 : CALIBRATION		
0xF400 : NO OP-STATION		
0xFF03 : AUX SUPPLY		
0xFF05 : PCB VERSION		
0xFF06 : PRODUCT CODE		



## Functional Description

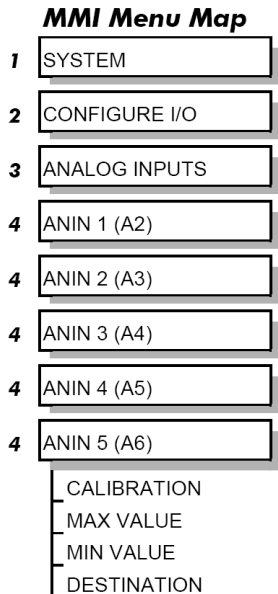


NOTE [1]:

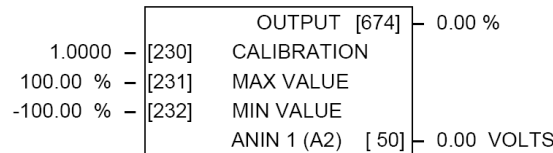
FIELD FAIL THRESHOLD IS 6% IN CURRENT CONTROL  
12% IN VOLTAGE CONTROL

# ANALOG INPUTS

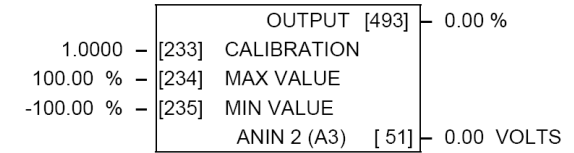
The analog input block is used to scale and clamp the inputs for terminals A2 to A6.



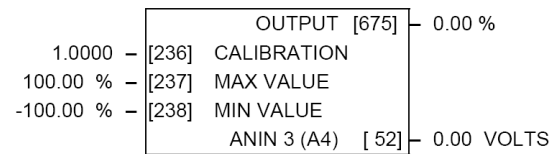
FUNCTION BLOCKS\INPUTS & OUTPUTS\ANALOG INPUT\ANALOG INPUT 1



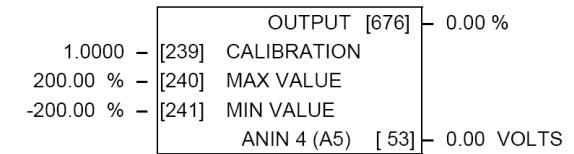
FUNCTION BLOCKS\INPUTS & OUTPUTS\ANALOG INPUT\ANALOG INPUT 2



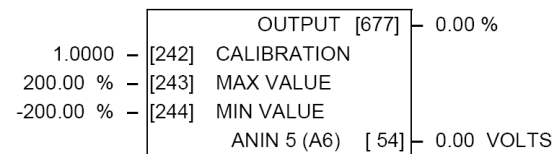
FUNCTION BLOCKS\INPUTS & OUTPUTS\ANALOG INPUT\ANALOG INPUT 3



FUNCTION BLOCKS\INPUTS & OUTPUTS\ANALOG INPUT\ANALOG INPUT 4



FUNCTION BLOCKS\INPUTS & OUTPUTS\ANALOG INPUT\ANALOG INPUT 5



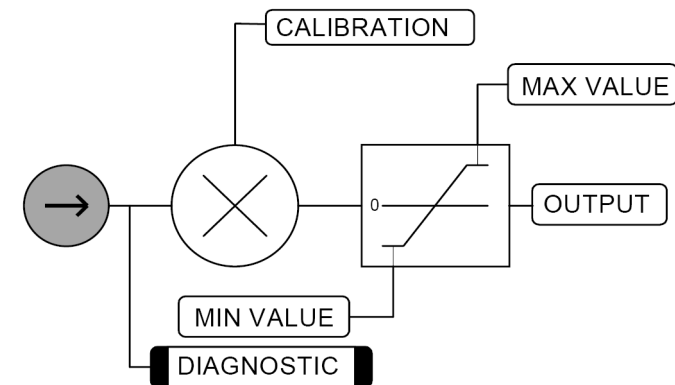
**NOTE**

Terminal ANIN 2 (A3) is permanently connected to SETPOINT 2 (A3) in the SPEED LOOP function block and to the Current Demand via I DEMAND ISOLATE (the current demand isolate switch) in the CURRENT LOOP function block.

To avoid interference with other drive functions when not required: the parameter RATIO 2 (A3) (Tag 7 in the SPEED LOOP function block) must be set to zero; and the I DMD. ISOLATE parameter (Tag 119 in the CURRENT LOOP function block) must be set to DISABLED, i.e. selecting the Speed Loop as shown in the Main Block Diagram.

Because ANIN 2 (A3) is scanned synchronously with the current loop (typically every 3.3/2.6ms, 50/60Hz), it should be used for any signal whose response is critical e.g. a trim input from an external positioning system or load share.

Configurable Analog Inputs

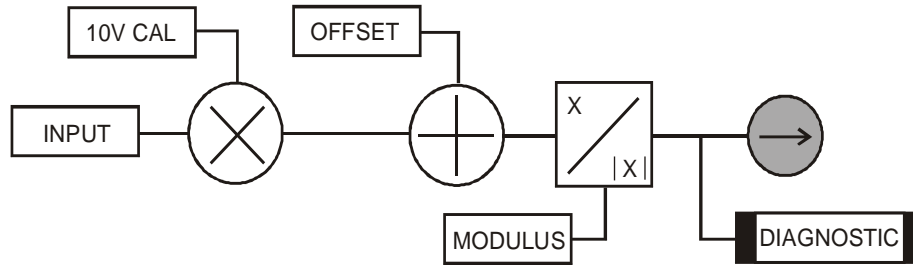


**ANALOG INPUTS**

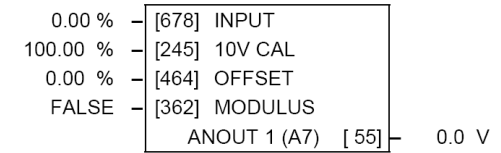
Parameter	Tag	Range
<b>CALIBRATION</b>	<b>230, 233, 236, 239, 242</b>	<b>-3.0000 to 3.0000</b>
The analog input scaling ratio. For a value of 1.0, 10V = 100%.		
<b>MAX VALUE</b>	<b>231, 234, 237, 240, 243</b>	<b>-300.00 to 300.00 %</b>
The maximum value of the scaled analog input.		
<b>MIN VALUE</b>	<b>232, 235, 238, 241, 244</b>	<b>-300.00 to 300.00 %</b>
The minimum value of the scaled analog input.		
<b>OUTPUT</b>	<b>674, 493, 675, 676, 677</b>	<b>— .xx %</b>
These parameters is the output diagnostic ANALOG INPUT 1 to ANALOG INPUT 5. Note by default 10V = 100%. To obtain a different range, adjust the CALIBRATION, MAX VALUE and MIN VALUE parameters.		
<b>ANIN 1 (A2) to ANIN 5 (A6)</b>	<b>50, 51, 52, 53, 54</b>	<b>— .xx VOLTS</b>
Actual volts measured on the analog input.		

## ANALOG OUTPUTS

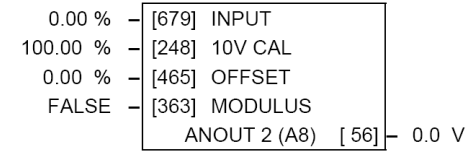
This function block converts the demand percentage into 0-10V, suitable for driving the analog output electronics of the drive.



FUNCTION BLOCKS INPUTS & OUTPUTS ANALOG OUTPUT ANALOG OUTPUT 1



FUNCTION BLOCKS INPUTS & OUTPUTS ANALOG OUTPUT ANALOG OUTPUT 2



- MMI Menu Map**
- 1 SYSTEM
  - 2 CONFIGURE I/O
  - 3 ANALOG OUTPUTS
  - 4 ANOUT 1 (A7)
  - 4 ANOUT 2 (A8)
    - % TO GET 10V
    - MODULUS
    - OFFSET
    - SOURCE TAG

### ANALOG OUTPUTS

Parameter	Tag	Range
<b>INPUT</b> Analog output value as a percentage of range.	<b>678, 679</b>	<b>-300.00 to 300.00 %</b>
<b>10V CAL</b> (% TO GET 10V) Scaler value which produces 10V output. Set 10V CAL to be 50% to get ±10V out for ±50% in.	<b>245, 248</b>	<b>-300.00 to 300.00 %</b>
<b>OFFSET</b> Offset value added to the normal output value after the scaler and before the modulus.	<b>464, 465</b>	<b>-100.00 to 100.00 %</b>
<b>MODULUS</b> Unipolar analog output enable. If TRUE, then -10% gives +1V out.	<b>362, 363</b>	<b>FALSE / TRUE</b>
<b>ANOUT 1 (A7) to ANOUT 2 (A8)</b> Actual voltage output to the terminal.	<b>55, 56</b>	<b>—.xx V (h)</b>

## AUTOTUNE

### MMI Menu Map

- 1 SETUP PARAMETERS
- 2 CURRENT LOOP
- AUTOTUNE

### MMI Menu Map

- 1 FUNCTION BLOCKS
- 2 MOTOR CONTROL
- 3 AUTOTUNE
  - STATE
  - METHOD
  - ERROR TYPE

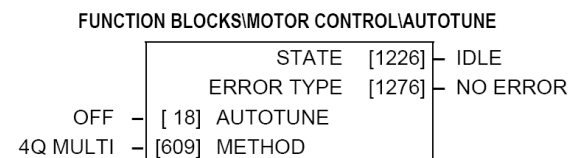
The Autotune feature is used to correctly set up the current loop controller parameters for the motor load.

The process consists of the drive generating a series of current pulses in the armature in order to determine:

1. The optimal proportional term and integral terms gains in the current controller, and storing these values as PROP. GAIN and INT. GAIN.
2. The average value at which the normal running pulses would just join up (stop being discontinuous), and storing this value as the DISCONTINUOUS parameter.

The Autotune is by default performed with the motor field off, and so the final proportional term gain is reduced by 30% to allow for some armature inductance fall-off when the field is re-applied.

Refer to Chapter 4: Performance Adjustment for details of how to perform an Autotune.



## AUTOTUNE

Parameter	Tag	Range
<b>AUTOTUNE</b>	<b>18</b>	<b>OFF / ARMATURE / FIELD</b>
Turns the AUTOTUNE procedure on, and selects if field or armature tuning is required. Refer to Chapter 4: Performance Adjustment.		
<b>STATE</b>	<b>1226</b>	<b>See below</b>
Indicates the current operating state of the Autotune function block. The FAILED state indicates failure or abort of the Autotune process (for causes refer to Chapter 4: Performance Adjustment).		
0 : IDLE 1 : RUNNING 2 : SUCCESS 3 : FAILED		
<b>METHOD</b>	<b>609</b>	<b>See below</b>
Controls the method of operation of the Autotune process.		
<ul style="list-style-type: none"> <li>• The default method 4QMULTI uses both thyristor bridges to generate balanced forward and reverse armature current pulses.</li> <li>• The 2QMULTI method only uses the forward thyristor bridge.</li> </ul>		
Note that the 2Q MULTI method is always used on a 2Q drive (591) irrespective of the setting of this parameter.		
0 : 4Q MULTI 1 : 2Q MULTI		

**AUTOTUNE**

Parameter	Tag	Range
<b>ERROR TYPE</b>	<b>1276</b>	<b>See below</b>
Indicates the cause of an autotune error condition.		
	0 : NO ERROR	
	1 : OVER SPEED	
	2 : FIELD ERROR	
	3 : PULSE WIDTH	
	4 : OVER CURRENT	
	5 : TIMEOUT	
	6 : AUTOTUNE ABORTED	
	7 : FIRING ANGLE	
	8 : PEAK/AVER. RATIO	
	9 : UNBALANCED BRID.	
	10 : NULL AVERAGE CUR	
	11 : THYRISTOR OFF (missing pulse)	

**Functional Description**

OVER SPEED	Motor speed detected at greater than 20% during autotune.
FIELD ERROR	Armature Autotune:  For a field-off armature autotune, it means that the field current was measured at greater than 6% of the calibration value (which, if the field is calibrated to a low current, can be a very low threshold).  For a field-on armature autotune, it means that the field was not up to current when expected during the autotune process.  Field Autotune: Field volts found to be less than 10% for 50% of rated field current flowing, or Field current measured at > 105% of rated during autotune.
PULSE WIDTH	Less than 12 pulses have been measured during the autotune that meeting the pulse width angle tolerance requirements – likely unstable/unbalanced supply or motor shaft moving.
OVER CURRENT	Equivalent discontinuous armature current level measured at greater than 200% of either the stack rating or ARMATURE CURRENT setting;
TIMEOUT	Various timeouts.

## D-26 Programming

AUTOTUNE ABORTED	User abort of the process.
FIRING ANGLE	Firing angle has reached 60deg. before zero voltage crossing, in an attempt to derive a 60deg. wide pulse – likely absent armature or severely resistive load.
PEAK/AVER.RATIO	Badly shaped current pulse, where the pk/average current ratio is more than 30% away from expected 1.5.
UNBALANCED BRID.	Pulse size imbalance greater than that from a motor BEMF equivalent to 5deg. from zero voltage crossing – likely poorly balanced supply phases or motor shaft turning.
NULL AVERAGE CUR	No current pulses detected.
THYRISTOR OFF	Missing pulse detected – likely missing firing pulses from one or more thyristors.

## AUX I/O

The auxiliary I/O parameters are primarily intended to extend the functionality of the serial links by allowing them access to the drive analog and digital terminals.

### MMI Menu Map

- 1 SETUP PARAMETERS
- 2 AUX I/O
  - AUX DIGOUT 1
  - AUX DIGOUT 2
  - AUX DIGOUT 3
  - ANOUT 1
  - ANOUT 2

FUNCTION BLOCKS\INPUTS & OUTPUTS\AUX I/O	
FALSE	[ 94] AUX DIGOUT 1
FALSE	[ 95] AUX DIGOUT 2
FALSE	[ 96] AUX DIGOUT 3
0.00 %	[128] ANOUT 1
0.00 %	[129] ANOUT 2

### AUX I/O

Parameter	Tag	Range
<b>AUX DIGOUT 1</b>	<b>94</b>	<b>FALSE / TRUE</b>
Software digital output 1. For example, to directly drive the configurable digital output DIGOUT1, connect the Source of DIGOUT1 to this parameter, Tag 94.		
<b>AUX DIGOUT 2</b>	<b>95</b>	<b>FALSE / TRUE</b>
Software digital output 2. For example, to directly drive the configurable digital output DIGOUT2, connect the Source of DIGOUT2 to this parameter, Tag 95.		
<b>AUX DIGOUT 3</b>	<b>96</b>	<b>FALSE / TRUE</b>
Software digital output 3. For example, to directly drive the configurable digital output DIGOUT3, connect the Source of DIGOUT3 to this parameter, Tag 96.		
<b>ANOUT 1</b>	<b>128</b>	<b>-100.00 to 100.00 %</b>
Software analog output 1. For example, to directly drive the configurable analog output ANOUT1, connect the Source of ANOUT1 to this parameter, Tag 128. ANOUT 1 can also be used as a general "staging post" for connecting inputs to outputs. For example, connect Analog Input 1 (A2) directly to Analog Output 1 (A7)		
<b>ANOUT 2</b>	<b>129</b>	<b>-100.00 to 100.00 %</b>
Software analog output 2. For example, to directly drive the configurable analog output ANOUT2, connect the Source of ANOUT2 to this parameter, Tag 129. ANOUT 2 can also be used as a general "staging post" for connecting inputs to outputs. For example, connect Analog Input 1 (A2) directly to Analog Output 2 (A8)		



# CALIBRATION

## MMI Menu Map

- 1 SETUP PARAMETERS
- 2 CALIBRATION
  - ARMATURE V CAL.
  - IR COMPENSATION
  - ANALOG TACH CAL
  - ZERO SPD. OFFSET
  - ARMATURE I (A9)
  - FIELD I CAL.

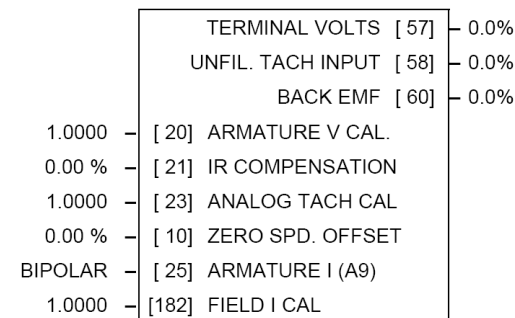
## MMI Menu Map

- 1 DIAGNOSTICS
  - TERMINAL VOLTS
  - BACK EMF
  - UNFIL. TACH INPUT

This function block contains motor-specific parameters.

When CONFIGURE ENABLE = TRUE, the operation of the Block Diagram is suspended and all Keypad LEDs will flash.

### FUNCTION BLOCKSIMOTOR CONTROLICALIBRATION



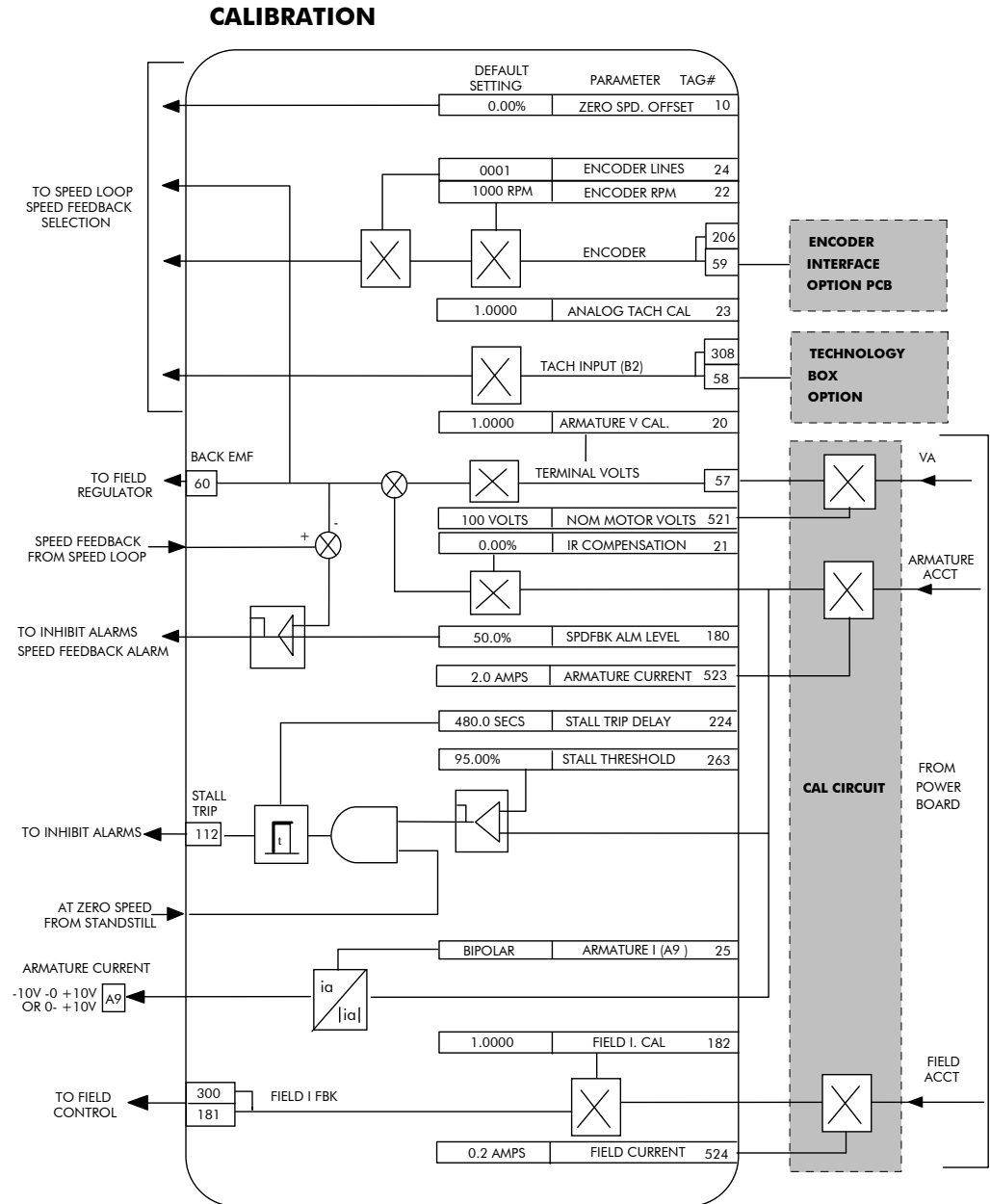
## CALIBRATION

Parameter	Tag	Range
<b>ARMATURE V CAL.</b>	<b>20</b>	<b>0.9800 to 1.1000</b>
Trim adjustment of the motor armature volts to give exactly 100% at the required actual voltage value (e.g. 460V etc.). Note: - Primary voltage calibration is achieved by adjusting the NOM MOTOR VOLTS parameter (CONFIGURE DRIVE function block).		
<b>IR COMPENSATION</b>	<b>21</b>	<b>0.00 to 100.00 %</b>
Compensation for motor IR drop to improve regulation when using armature voltage feedback as the speed feedback. This is also used in field weakening applications to improve dynamic response and speed holding stability, refer to “Initial Start-up Routine” in Chapter 4, Item 16.		
<b>ANALOG TACH CAL</b>	<b>23</b>	<b>0.9800 to 1.1000</b>
Trim adjustment of the motor speed to give exactly 100% at the required actual speed value (e.g. 1500 RPM etc). <i>Note: Primary tacho calibration is achieved by adjusting SW1 - 3 on the tacho calibration board.</i>		
<b>ZERO SPD. OFFSET</b>	<b>10</b>	<b>-5.00 to 5.00 %</b>
If the speed feedback is not zero when the motor is stationary (possibly due to hardware offsets etc.) the setting of this parameter to the value of the offset will result in a zero reading from the speed feedback.		
<b>ARMATURE I (A9)</b>	<b>25</b>	<b>UNIPOLAR / BIPOLAR</b>
Selects operation of the current meter output (terminal A9), either bipolar or unipolar. Bipolar mode : +10V = 200% output current forward, -10V = 200% output current reverse Unipolar mode : +10V = 200% output current		
<b>FIELD I CAL.</b>	<b>182</b>	<b>0.9800 to 1.1000</b>
Trim adjustment of the motor field current to give exactly 100% at the required actual current value (e.g. 1.5A etc.). Note:- Primary field calibration is achieved by adjusting the FIELD CURRENT parameter (CONFIGURE DRIVE function block).		

**CALIBRATION**

Parameter	Tag	Range
<b>TERMINAL VOLTS</b>	<b>57</b>	<b>—.x % (h)</b>
<i>Refer to Chapter 6: "The Keypad" - The Keypad Menus (DIAGNOSTICS).</i>		
<b>UNFIL. TACH INPUT</b>	<b>58</b>	<b>—.x % (h)</b>
<i>Refer to Chapter 6: "The Keypad" - The Keypad Menus (DIAGNOSTICS).</i>		
<b>BACK EMF</b>	<b>60</b>	<b>—.x % (h)</b>
<i>Refer to Chapter 6: "The Keypad" - The Keypad Menus (DIAGNOSTICS).</i>		

# Functional Description



FUNCTION BLOCKS|COMMUNICATIONS|COMMS PORT|COMMS PORT 3

EIASCII	-	[130]	MODE
19200	-	[198]	BAUD RATE
0	-	[329]	GROUP ID (GID)
0	-	[330]	UNIT ID (UID)
TRUE	-	[328]	ESP SUP. (ASCII)
0.00 %	-	[331]	CHANGEBAND (BIN)
0xFFFF	-	[333]	PNO.7
0x00C0	-	[332]	ERROR REPORT
2 ms	-	[1175]	REPLY DELAY

## COMMS PORT

Use this block to configure the drive's P3 port.

Refer to Appendix A: "Serial Communications" - System Port P3 for further information.

The P3 port is a non-isolated serial communications port built in to the drive's Control Board.

It is used off-line (while the drive is stopped) for transferring and saving drive configuration files using a personal computer (PC) running a serial communications program, or on-line (while the drive is running) when using the Parker SSD Drives 5703 Setpoint Repeater Unit.

You can also use the P3 port to transfer configuration files by connecting to a PC running the Windows™ compatible software package "DSELite". Refer to the DSELite Configuration Tool Software Manual HA471486.

### MMI Menu Map

- 1 SETUP PARAMETERS
- 2 SERIAL LINKS
- 3 SYSTEM PORT (P3)
  - MODE
  - GROUP ID (UID)
  - UNIT ID (UID)
  - ERROR REPORT
  - BAUD RATE

### MMI Menu Map

- 1 FUNCTION BLOCKS
- 2 COMMUNICATIONS
- 3 COMMS PORT
- 4 COMMS PORT 3
  - MODE
  - BAUD RATE
  - GROUP ID (GID)
  - UNIT ID (UID)
  - ESP SUP. (ASCII)
  - CHANGEBAND (BIN)
  - PNO.7
  - ERROR REPORT
  - REPLY DELAY

## COMMS PORT

Parameter	Tag	Range
<b>MODE</b>	<b>130</b>	<b>See below</b>
Used to set the protocol on this port.		
	0 : DISABLED	
	1 : 5703 MASTER	
	2 : 5703 SLAVE	
	3 : EIASCII	
	4 : EIBINARY	
<b>BAUD RATE</b>	<b>198</b>	<b>See below</b>
Transmission rate. Options available are:		
	0 : 300	
	1 : 600	
	2 : 1200	
	3 : 2400	
	4 : 4800	
	5 : 9600 (default)	
	6 : 19200	
	7 : 38400	
	8 : 57600	
	9 : 115200	
<b>GROUP ID (GID)</b>	<b>329</b>	<b>0 to 7</b>
The Parker SSD Drives protocol group identity address.		

<b>COMMS PORT</b>		
<b>Parameter</b>	<b>Tag</b>	<b>Range</b>
<b>UNIT ID (UID)</b> The Parker SSD Drives protocol unit identity address.	<b>330</b>	<b>0 to 255</b>
<b>ESP SUP. (ASCII)</b> <i>Reserved for future use.</i>	<b>328</b>	<b>FALSE/TRUE</b>
<b>CHANGE BAND (BIN)</b> <i>Reserved for future use.</i>	<b>331</b>	<b>0.00 to 100.00 %</b>
<b>PNO.7</b> <i>Reserved for future use.</i>	<b>333</b>	<b>0x0000 to 0xFFFF</b>
<b>ERROR REPORT</b> Displays the last error as a hexadecimal code. Writing any value to this parameter will set the value to >00C0 (No Error). Refer to Appendix A: "Serial Communications" - Reference for a list of codes.	<b>332</b>	<b>0x0000 to 0xFFFF</b>
<b>DELAY</b> A programmable delay inserted by the drive before replying to a request.	<b>1175</b>	<b>0 to 255 ms</b>

## CONFIGURE DRIVE

This block contains many of the parameters required for configuring the drive.

**NOTE** The CONFIGURE DRIVE menu on the MMI contains a different set of parameters, for set-up using the keypad.

CONFIGURE ENABLE: The operation of the Block Diagram is suspended and all Keypad LEDs will flash whilst CONFIGURE ENABLE = TRUE.

**NOTE** The CONFIGURE ENABLE parameter is also available in the following MMI menus for ease of use: CALIBRATION, CONFIGURE I/O

	FUNCTION BLOCKS	MISCELLANEOUS	CONFIGURE DRIVE
DISABLED	[ 39]	CONFIGURE ENABLE	
100 V	[521]	NOM MOTOR VOLTS	
1.0 A	[523]	ARMATURE CURRENT	
0.2 A	[524]	FIELD CURRENT	
FALSE	[1220]	AUTOMATIC SAVE	
FALSE	[1169]	DUMP CHANGED	
FALSE	[628]	UDP USE OP PORT	
0x0001	[162]	EMULATE 590P	
TRUE	[1172]	DEBOUNCE DIGIN	

**MMI Menu Map**

- 1 CONFIGURE DRIVE
  - CONFIGURE ENABLE
  - NOM MOTOR VOLTS
  - ARMATURE CURRENT
  - FIELD CURRENT

**MMI Menu Map**

- 1 SERIAL LINKS
- 2 SYSTEM PORT (P3)
  - DUMP CHANGED
  - DUMP MMI (TX)

**MMI Menu Map**

- 1 FUNCTION BLOCKS
- 2 MISCELLANEOUS
- 3 CONFIGURE DRIVE
  - AUTOMATIC SAVE
  - UDP USE OP PORT
  - EMULATE 590P
  - DEBOUNCE DIGIN

### CONFIGURE DRIVE

Parameter	Tag	Range
<b>CONFIGURE ENABLE</b>	<b>39</b>	<b>FALSE / TRUE</b>
Selects Operating Mode (FALSE) or Configuration Mode (TRUE). Refer to “Modifying a Block Diagram”, page D-1.		
<b>NOM MOTOR VOLTS</b>	<b>521</b>	<b>100 to 875 VOLTS</b>
Sets the 100% value for Armature Volts VA. Set this value to match the motor in use. (Refer to ARMATURE V CAL in the CALIBRATION function block).		
<b>ARMATURE CURRENT</b>	<b>523</b>	<b>Product code dependent AMPS</b>
Sets the 100% value for Armature Current IA. Set this value to match the motor in use.		
<b>FIELD CURRENT</b>	<b>524</b>	<b>Product code dependent AMPS</b>
Sets the 100% value for Field Current IF. Set this value to match the motor in use. Note: this should be set to a minimum value if in Field Voltage control - see FLD. CTRL MODE in the FIELD CONTROL function block.		
<b>AUTOMATIC SAVE</b>	<b>1220</b>	<b>FALSE/TRUE</b>
When TRUE, changes made to parameters using the operator station are automatically saved to the drive’s non-volatile memory.		
<b>DUMP CHANGED</b>	<b>1169</b>	<b>FALSE /TRUE</b>
This parameter is used in conjunction with DUMP MMI (TX) and DUMP BLOCKS. When TRUE, only those parameters that have been modified from their default value are included in the dump.		
<b>UDP USE OP PORT</b>	<b>628</b>	<b>FALSE/TRUE</b>
When TRUE the UDP transfer will be re-directed to the operator station port.		
<b>EMULATE 590P</b>	<b>162</b>	<b>0x0000 to 0xFFFF</b>
When non-zero the drive emulates some behaviour of earlier firmware versions of the 590P, (firmware versions 5.x and 7.x). This behaviour affects the time constants of the PID block and the linking of parameters in the function block diagram (refer to "Compatibility with Earlier Versions of Firmware". page D-7).		
<b>DEBOUNCE DIGIN</b>	<b>1172</b>	<b>FALSE/TRUE</b>
When TRUE the drive adds a 3ms debounce filter to the digital inputs. This affects terminals C3 to C8, B8 and B9. The hardware connection between terminal B9, (COAST STOP) and the control of the external contactor is not affected.		

**MMI Menu Map**

- 1 SETUP PARAMETERS
- 2 CURRENT LOOP
  - MAIN CURR. LIMIT
  - PROP. GAIN
  - INT. GAIN
  - DISCONTINUOUS
  - ADDITIONAL DEM
  - BIPOLAR CLAMPS
  - REGEN ENABLE
  - MASTER BRIDGE
  - POS. I CLAMP IN
  - NEG. I CLAMP IN
  - I DMD. ISOLATE
  - CUR. LIMIT/SCALER

**MMI Menu Map**

- 1 DIAGNOSTICS
  - CURRENT DEMAND
  - CURRENT FBK. AMPS
  - IaFbk UNFILTERED
  - IaDmd UNFILTERED
  - POS. I CLAMP
  - NEG. I CLAMP
  - ACTUAL POS I LIM
  - ACTUAL NEG I LIM
  - AT CURRENT LIMIT
  - BACK EMF

**MMI Menu Map**

- 1 FUNCTION BLOCKS
- 2 MOTOR CONTROL
- 3 CURRENT LOOP
  - PHASE ANGLE @ E
  - ISOL DMD SOURCE

## CURRENT LOOP

Use this to setup the drive's conventional current/torque loop.

It takes the current demand, imposes limits through four clamps, and then uses a PI loop to control the output.

The four separate clamps - current profile, inverse time overload, bipolar clamps and main current clamp - the clamps are in series and lowest clamp takes effect. The resultant clamp value can be seen in the diagnostics ACTUAL POS I LIM and ACTUAL NEG I LIM.

The internal inputs to this block are:

- the current demand from the speed loop or terminal A3 (selected via I DMD. ISOLATE)
- the current limit clamps from CURRENT PROFILE and INVERSE TIME (note that the bipolar clamps and main current clamp are resident in the CURRENT LOOP block)
- current feedback from CALIBRATION.

The default configuration uses DIGIN 1 and DIGIN 3 for switching modes (BIPOLAR CLAMPS and I DMD. ISOLATE respectively), ANIN 5 for setting the symmetrical positive and negative current clamps.

FUNCTION BLOCKS\MOTOR CONTROL\CURRENT LOOP

AT CURRENT LIMIT	[ 42]	FALSE
IaDmd UNFILTERED	[ 66]	0.00 %
CURRENT DEMAND	[299]	0.00 %
IaFbk UNFILTERED	[ 65]	0.0 %
CURRENT FBK.AMPS	[538]	0.0 A
MASTER BRIDGE	[527]	TRUE
BACK EMF	[1173]	0.00 V
PHASE ANGLE @ E	[1174]	0.00 DEG
POS. I CLAMP	[ 87]	0.0 %
NEG. I CLAMP	[ 88]	0.0 %
ACTUAL POS I LIM	[ 67]	0.0 %
ACTUAL NEG I LIM	[ 61]	0.0 %
100.00 %	[ 15]	CUR. LIMIT/SCALER
110.00 %	[421]	MAIN CURR. LIMIT
45.00	[ 16]	PROP. GAIN
3.50	[ 17]	INT. GAIN
12.00 %	[137]	DISCONTINUOUS
0.00 %	[ 30]	ADDITIONAL DEM
DISABLED	[ 90]	BIPOLAR CLAMPS
4Q (REGEN)	[201]	REGEN ENABLE
250.00 %	[301]	POS. I CLAMP IN
-250.00 %	[ 48]	NEG. I CLAMP IN
DISABLED	[119]	I DMD. ISOLATE
ANIN 2 (A3)	[1275]	ISOL DMD SOURCE

## CURRENT LOOP

Parameter	Tag	Range
<b>CUR. LIMIT/SCALER</b>	<b>15</b>	<b>0.00 to 200.00 %</b>
Current limit scaler. It scales bipolar/unipolar clamps. To achieve 200% current limit, the current limit scaler should be set to 200%.		
<b>MAIN CURR. LIMIT</b>	<b>421</b>	<b>0.00 to 200.00 %</b>
Independent symmetric current clamp. Sets symmetric clamps outside scaling from the CUR. LIMIT/SCALER parameter.		
<b>PROP GAIN</b>	<b>16</b>	<b>0.00 to 200.00</b>
Proportional gain control for armature current PI loop. This parameter is set during the autotune function.		
<b>INT. GAIN</b>	<b>17</b>	<b>0.00 to 200.00</b>
Integral gain control for armature current PI loop, set during the autotune function.		

<b>CURRENT LOOP</b>		
<b>Parameter</b>	<b>Tag</b>	<b>Range</b>
<b>DISCONTINUOUS</b>	<b>137</b>	<b>0.00 to 200.00 %</b>
Sets the boundary current between the discontinuous and continuous regions of operation. This is set during the autotune function and affects the performance of the adaptive algorithm.		
<b>ADDITIONAL DEM</b>	<b>30</b>	<b>-200.00 to 200.00 %</b>
Additional current demand input.		
<b>BIPOLAR CLAMPS</b>	<b>90</b>	<b>DISABLED / ENABLED</b>
Selects between bipolar (asymmetric) or unipolar (symmetric) current clamps for the 4 quadrants of operation. Default setting of DISABLED means UNIPOLAR clamps selected.		
<p style="text-align: center;">DISABLED - unipolar (symmetric) ENABLED - bipolar (asymmetric)</p> <p>With BIPOLAR CLAMPS disabled, the clamps are symmetrical and are set by POS. I CLAMP IN. With BIPOLAR CLAMPS enabled, the clamps are assymmetrical, bipolar. In bipolar mode, POS. I CLAMP IN sets the maximum positive current and NEG. I CLAMP IN sets the maximum negative current. Both clamps can be positive or negative, however, the POS I CLAMP IN value is internally prevented from going numerically below the NEG I CLAMP IN. CUR. LIMIT/SCALER scales both POS. I CLAMP IN and NEG. I CLAMP IN.</p>		
<b>REGEN ENABLE</b>	<b>201</b>	<b>See below</b>
When REGEN ENABLE is 2Q (NON-REGEN), negative current demands are clamped to zero. Current feedback is subtracted from the current demand and the result is controlled by the PI loop. The result provides SCR phase angle control.		
<p style="text-align: center;">2Q (NON-REGEN) - non-regenerative (2-quadrant) 4Q (REGEN) - regenerative (4-quadrant)</p>		
<b>POS. I CLAMP IN</b>	<b>301</b>	<b>-200.00 to 200.00 %</b>
Positive current clamp when BIPOLAR CLAMPS is ENABLED.		
<b>NEG. I CLAMP IN</b>	<b>48</b>	<b>-200.00 to 200.00 %</b>
<p>Negative current clamp when BIPOLAR CLAMPS is ENABLED.</p> <p><i>Note on bipolar current clamps: these clamps in bipolar mode can cross-over onto the same quadrant. The POS. I CLAMP IN value is internally prevented from going numerically below the NEG. I CLAMP IN.</i></p>		



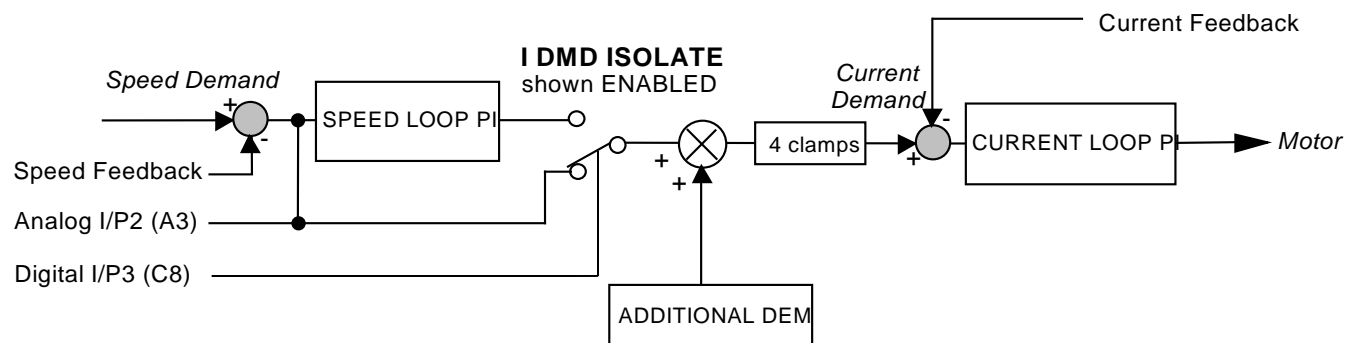
## CURRENT LOOP

Parameter	Tag	Range
-----------	-----	-------

<b>I DMD. ISOLATE</b>	<b>119</b>	<b>DISABLED / ENABLED</b>
-----------------------	------------	---------------------------

Speed loop bypass; the current demand is taken from ANIN 2 (A3).

With I DMD. ISOLATE disabled, the current loop uses the current demand from the speed loop. With I DMD. ISOLATE enabled, ANALOG I/P 2, terminal A3, supplies the current demand. With default scaling, 10V dc on terminal A3 is 100% current demand. An additional current input, ADDITIONAL DEM, can be added to the current demand. The simplified diagram below, with reference to the default Block Diagram, shows how the I DMD ISOLATE parameter selects the controlling loop.



<b>AT CURRENT LIMIT</b>	<b>42</b>	<b>FALSE / TRUE</b>
<i>Refer to Chapter 6: "The Keypad" - The Keypad Menus (DIAGNOSTICS).</i>		
<b>IaDmd UNFILTERED</b>	<b>66</b>	<b>—x % (h)</b>
<i>Refer to Chapter 6: "The Keypad" - The Keypad Menus (DIAGNOSTICS).</i>		
<b>CURRENT DEMAND</b>	<b>299</b>	<b>—xx %</b>
<i>Refer to Chapter 6: "The Keypad" - The Keypad Menus (DIAGNOSTICS).</i>		
<b>IaFbk UNFILTERED</b>	<b>65</b>	<b>—x % (h)</b>
<i>Refer to Chapter 6: "The Keypad" - The Keypad Menus (DIAGNOSTICS).</i>		
<b>CURRENT FBK. AMPS</b>	<b>538</b>	<b>—x AMPS</b>
<i>Refer to Chapter 6: "The Keypad" - The Keypad Menus (DIAGNOSTICS).</i>		
<b>MASTER BRIDGE</b>	<b>527</b>	<b>FALSE/TRUE</b>
A diagnostic indicating currently active bridge; master = TRUE, slave = FALSE.		
<b>BACK EMF</b>	<b>1173</b>	<b>—x V</b>
<i>Refer to Chapter 6: "The Keypad" - The Keypad Menus (DIAGNOSTICS).</i>		
<b>PHASE ANGLE @ E</b>	<b>1174</b>	<b>—x DEG</b>
The motor back EMF, presented as the angle at which the supply volts matches it. This is the instantaneous angle above which firing the thyristor would just start to make armature current.		

**CURRENT LOOP**

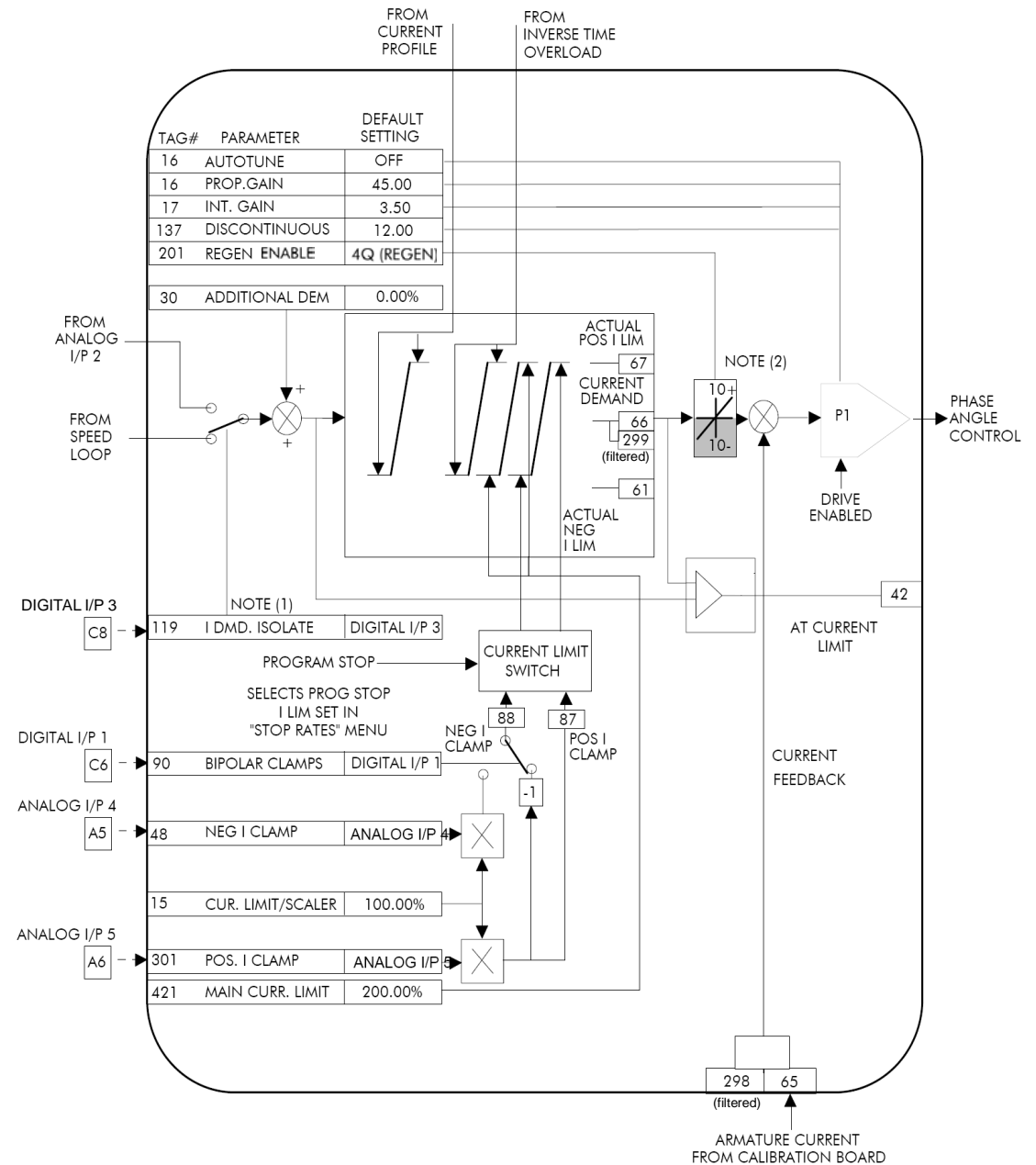
Parameter	Tag	Range
<b>POS. I CLAMP</b>	<b>87</b>	—x %
<i>Refer to Chapter 6: "The Keypad" - The Keypad Menus (DIAGNOSTICS).</i>		
<b>NEG. I CLAMP</b>	<b>88</b>	—x %
<i>Refer to Chapter 6: "The Keypad" - The Keypad Menus (DIAGNOSTICS).</i>		
<b>ACTUAL POS I LIM</b>	<b>67</b>	—x %
<i>Refer to Chapter 6: "The Keypad" - The Keypad Menus (DIAGNOSTICS).</i>		
<b>ACTUAL NEG I LIM</b>	<b>61</b>	—x %
<i>Refer to Chapter 6: "The Keypad" - The Keypad Menus (DIAGNOSTICS).</i>		
<b>ISOL DMD SOURCE</b>	<b>1275</b>	<b>ANIN 2 (A3) / FIELD I DEMAND</b>
Selects the source of the isolated current demand.		
<ul style="list-style-type: none"> <li>➤ Setting ANIN 2 (A3) makes use of the A3 analogue input terminal as the current demand.</li> <li>➤ Setting FIELD I DEMAND makes use of the current demand (%) at the field current controller, as the percentage armature current demand.</li> </ul>		
The use of this parameter is typically combined with parameters BEMF SOURCE, BEMF INPUT and 3-PHASE FIELD to apply the drive to field weakening control of a motor field.		

## Functional Description

Note 1: I DMD. ISOLATE removes speed loop demand and selects analog I/P 2 as current regulator demand.  
I DMD. ISOLATE is overridden by program stop and stop to return drive to speed regulation.

Note 2: REGEN ENABLE = 2Q (NON-REGEN) prevents negative current demand. Non-regenerative drives use non-regen mode irrespective of the REGEN ENABLE parameter setting.

## CURRENT LOOP



**MMI Menu Map**

- 1 **SETUP PARAMETERS**
- 2 **CURRENT PROFILE**
  - SPD BRK1 (LOW)
  - SPD BRK2 (HIGH)
  - IMAX BRK1 (SPD1)
  - IMAX BRK2 (SPD2)

## CURRENT PROFILE

Use this to clamp the current limit for applications where motors have a reduced ability to commutate armature current at low field currents.

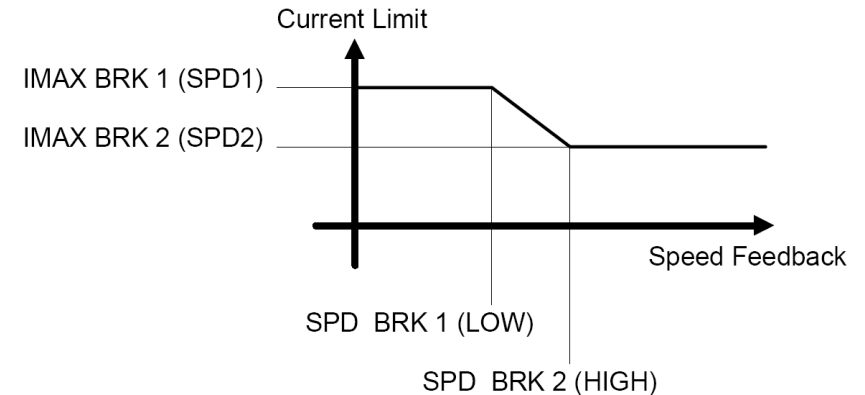
Normally this is required when using Field Weakening, although some motors exhibit commutation limitations at higher speeds even with rated field current.

The input to the block is SPEED FEEDBACK from the SPEED LOOP function block. The output of the block changes the current limit clamp in the current loop.

- When SPEED FEEDBACK exceeds SPD BRK 1 (LOW), the current profile begins scaling the current limit as set by IMAX BRK 1 (SPD1).
- As the SPEED FEEDBACK increases toward SPD BRK 2 (HIGH), the current limit is reduced linearly toward IMAX BRK 2 (SPD2).
- When the speed exceeds SPD BRK 2 (HIGH), the current limit remains at the IMAX BRK 2 (SPD2) setting.

FUNCTION BLOCKS MOTOR CONTROL CURRENT PROFILE

100.0 %	-	[ 32 ]	SPD BRK 1 (LOW)
100.0 %	-	[ 31 ]	SPD BRK 2 (HIGH)
200.0 %	-	[ 93 ]	IMAX BRK 1 (SPD1)
200.0 %	-	[ 33 ]	IMAX BRK 2 (SPD2)

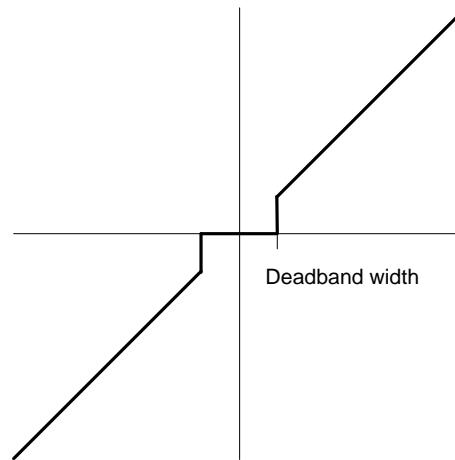
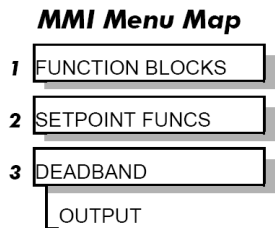
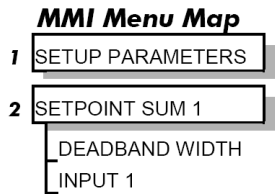
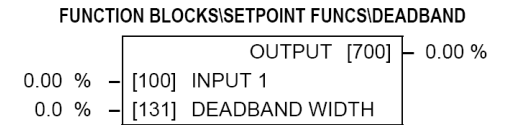


### CURRENT PROFILE

Parameter	Tag	Range
<b>SPD BRK 1 (LOW)</b>	<b>32</b>	<b>0.0 to 100.0 % (h)</b>
This is the motor speed at which current limit profiling begins.		
<b>SPD BRK 2 (HIGH)</b>	<b>31</b>	<b>0.0 to 100.0 % (h)</b>
This is the upper speed limit at which current limit profiling ends.		
<b>IMAX BRK 1 (SPD1)</b>	<b>93</b>	<b>0.0 to 200.0 % (h)</b>
This sets the current limit value at or below speed break-point 1, provided the other current limit clamps (inverse time overload, bipolar clamps and main current clamps) are greater than this setting.		
<b>IMAX BRK 2 (SPD2)</b>	<b>33</b>	<b>0.0 to 200.0 % (h)</b>
This sets the current limit value at or above speed break-point 2, provided the other current limit clamps setting (inverse time overload, bipolar clamps and main current clamps) are greater than this.		

## DEADBAND

When the input is within the deadband, the output is clamped to zero to ignore any noise. The limits are symmetrical around zero. The limits are set by the DEADBAND parameter.



### DEADBAND

Parameter	Tag	Range
<b>INPUT 1</b>	<b>100</b>	<b>-200.00 to 200.00 %</b>
Input 1 value. By default this is connected to Analog Input 1 (terminal A2).		
<b>DEADBAND</b>	<b>131</b>	<b>0.0 to 100.0 %</b>
Range within which the output is clamped at zero.		
<b>OUTPUT</b>	<b>700</b>	<b>—.xx %</b>
Modified value of input.		

**MMI Menu Map**

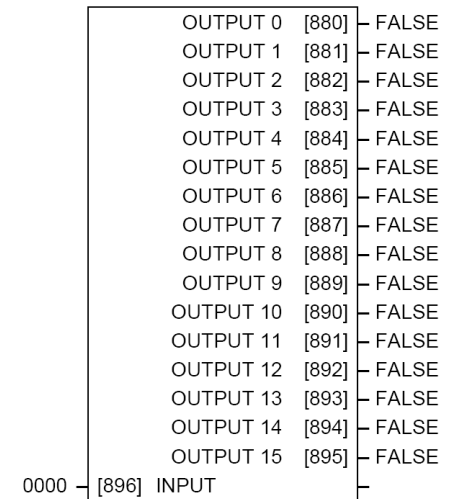
- 1 **FUNCTION BLOCKS**
- 2 **MISCELLANEOUS**
- 3 **DEMULTIPLEXER**
  - INPUT
  - OUTPUT 0
  - OUTPUT 1
  - OUTPUT 2
  - OUTPUT 3
  - OUTPUT 4
  - OUTPUT 5
  - OUTPUT 6
  - OUTPUT 7
  - OUTPUT 8
  - OUTPUT 9
  - OUTPUT 10
  - OUTPUT 11
  - OUTPUT 12
  - OUTPUT 13
  - OUTPUT 14
  - OUTPUT 15

## DEMULTIPLEXER

The demultiplexer function block splits the input word into 16 individual bits.

This may be used to extract the individual trip bits from the ACTIVE TRIPS parameter, for example.

FUNCTION BLOCKS\MISCELLANEOUS\DEMULTIPLEXER



### DEMULTIPLEXER

Parameter	Tag	Range
<b>INPUT</b>	<b>896</b>	<b>0x0000 to 0xFFFF</b>
The input to be split into its component bits.		
<b>OUTPUT 0 to OUTPUT 15</b>	<b>880 to 895</b>	<b>FALSE / TRUE</b>
Each output returns the corresponding bit of the 16 bit input word.		

## DIAMETER CALC.

### MMI Menu Map

1	SETUP PARAMETERS
2	SPECIAL BLOCKS
3	DIAMETER CALC.
	LINE SPEED
	REEL SPEED
	MIN DIAMETER
	MIN SPEED
	RESET VALUE
	EXTERNAL RESET
	RAMP RATE
	DIAMETER
	MOD OF LINE SPD
	MOD OF REEL SPD
	UNFILT DIAMETER

This block performs three functions.

**DIAMETER CALC:** Used to calculate roll diameters in winder applications.

**TAPER CALC:** Used to profile the tension demand with diameter.

**TENS+COMP CALC:** Used to provide additional torque to compensate for static and dynamic friction, as well as load inertia.

These three functions are combined into one function block as they are functionally closely coupled.

DIAMETER CALC calculates the diameter of a reel as a function of the reel speed and the line speed. The resulting diameter is a percentage of the maximum full roll diameter. A lead section, adjacent line section, or surface driven speed sensing device is required to supply the line speed signal. The winder or unwind drive's motor speed feedback provides the reel speed input.

The ratio of the minimum core diameter to the maximum roll diameter determines the operating range of the diameter calculator. Set MIN DIAMETER to that ratio using the expression:

$$\text{Minimum Core Outside Diameter} \div \text{Maximum Full Roll Diameter} \times 100\%$$

The magnitude of LINE SPEED is compared with MIN SPEED to determine when the diameter calculator will operate:

- When LINE SPEED is above MIN SPEED the calculator is on
- When LINE SPEED is below MIN SPEED, DIAMETER is held at the last calculated diameter

When EXTERNAL RESET is ENABLED, RESET VALUE is used as the diameter output.

**NOTE** In turret winder applications, LINE SPEED will usually be above MIN SPEED. During roll changes, EXTERNAL RESET must be held ENABLED for the new spindle until the web has been transferred and the diameter is calculated properly. RESET VALUE must be set to the appropriate new core value for a rewind, or new roll diameter for an unwind.

RAMP RATE adjusts the filtering of the diameter output. Its setting is the time it takes for a 100% change in DIAMETER. For example, at the default setting of 5.0 seconds, a 50% step change in diameter would take 2.5 seconds for the output diameter output to display the change.

### FUNCTION BLOCKS\WINDER\DIAMETER CALC.

	DIAMETER	[427]	0.00 %
	MOD OF LINE SPD	[428]	0.00 %
	MOD OF REEL SPD	[429]	0.00 %
	UNFILT DIAMETER	[430]	0.00 %
	TAPERED DEMAND	[452]	0.00 %
	TOT. TENS. DEMAND	[441]	0.00 %
	INERTIA COMP O/P	[485]	0.00 %
	OUTPUT	[706]	0.00 %
0.00 %	-	[424] LINE SPEED	
0.00 %	-	[437] REEL SPEED	
10.00 %	-	[425] MIN DIAMETER	
5.00 %	-	[426] MIN SPEED	
10.00 %	-	[462] RESET VALUE	
FALSE	-	[463] EXTERNAL RESET	
5.0 s	-	[453] RAMP RATE	
0.00 %	-	[438] TAPER	
0.00 %	-	[439] TENSION SPT.	
0.00 %	-	[440] TENSION TRIM	
0.00 %	-	[487] STATIC COMP	
0.00 %	-	[488] DYNAMIC COMP	
TRUE	-	[489] REWIND	
0.00 %	-	[479] FIX. INERTIA COMP	
0.00 %	-	[480] VAR. INERTIA COMP	
100.00 %	-	[481] ROLL WIDTH/MASS	
0.00 %	-	[498] LINE SPEED SPT	
10	-	[482] FILTER T.C.	
10.00	-	[483] RATE CAL	
0.00 %	-	[484] NORMALISED dv/dt	
1.0000	-	[486] TENSION SCALER	

### MMI Menu Map

1	SETUP PARAMETERS
2	SPECIAL BLOCKS
3	TAPER CALC.
	TAPER
	TENSION SPT
	TAPERED DEMAND
	TENSION TRIM
	TOT. TENS. DEMAND

**MMI Menu Map**

- 1 SETUP PARAMETERS
- 2 SPECIAL BLOCKS
- 3 TENS+COMP CALC.
  - STATIC COMP
  - DYNAMIC COMP
  - REWIND
  - FIX. INERTIA COMP
  - VAR. INERTIA COMP
  - ROLL WIDTH/MASS
  - LINE SPEED SPT
  - FILTER T.C.
  - RATE CAL
  - NORMALISED dv/dt
  - INERTIA COMP O/P
  - TENSION SCALER

**MMI Menu Map**

- 1 FUNCTION BLOCKS
- 2 WINDER
  - OUTPUT

**DIAMETER CALC.**

Parameter	Tag	Range
<b>LINE SPEED</b>	<b>424</b>	<b>-105.00 to 105.00 %</b>
This will usually be configured to be the analog tacho input and scaled appropriately during calibration.		
<b>REEL SPEED</b>	<b>437</b>	<b>-105.00 to 105.00 %</b>
This will usually be configured to be the drive's own speed feedback, i.e. encoder or armature volts feedback.		
<b>MIN DIAMETER</b>	<b>425</b>	<b>0.00 to 100.00 %</b>
Set to the minimum core diameter (normally the empty core diameter) as a percentage of the maximum roll diameter.		
<b>MIN SPEED</b>	<b>426</b>	<b>0.00 to 100.00 %</b>
This is the minimum LINE SPEED level below which the diameter calculation is frozen.		
<b>RESET VALUE</b>	<b>462</b>	<b>0.00 to 100.00 %</b>
Normally for winders this will be set to the MIN DIAMETER value. It is the diameter preset used when changing rolls. This value will be preloaded into the ramp (filter) output when EXTERNAL RESET is enabled.		
<b>EXTERNAL RESET</b>	<b>463</b>	<b>DISABLED / ENABLED</b>
Sets and holds the diameter to the RESET VALUE when ENABLED.		
<b>RAMP RATE</b>	<b>453</b>	<b>0.1 to 600.0 s</b>
This is used to smooth the output of the diameter calculator.		
<b>TAPER</b>	<b>438</b>	<b>-100.00 to 100.00 %</b>
This defines the amount of tapering in the tension demand with diameter variation. When TAPER is positive, the tension demand is hyperbolically decreased as diameter increases.		
<b>TENSION SPT.</b>	<b>439</b>	<b>0.00 to 100.00 %</b>
This is the required tension setpoint.		
<b>TENSION TRIM</b>	<b>440</b>	<b>-100.00 to 100.00 %</b>
This is the additional tension demand in the form of a trim.		
<b>STATIC COMP</b>	<b>487</b>	<b>-300.00 to 300.00 %</b>
Static friction compensation set-up parameter.		
<b>DYNAMIC COMP</b>	<b>488</b>	<b>-300.00 to 300.00 %</b>
Dynamic friction compensation set-up parameter.		
<b>REWIND</b>	<b>489</b>	<b>DISABLED / ENABLED</b>
Switches the sign of the friction compensations when the motor changes direction. Set to DISABLED only when the winder reverses.		



## MMI Menu Map

- 1 SETUP PARAMETERS
- 2 SPECIAL BLOCKS
- 3 TENS+COMP CALC.
  - STATIC COMP
  - DYNAMIC COMP
  - REWIND
  - FIX. INERTIA COMP
  - VAR. INERTIA COMP
  - ROLL WIDTH/MASS
  - LINE SPEED SPT
  - FILTER T.C.
  - RATE CAL
  - NORMALISED dv/dt
  - INERTIA COMP O/P
  - TENSION SCALER

## DIAMETER CALC.

Parameter	Tag	Range
<b>FIX. INERTIA COMP</b>	<b>479</b>	<b>-300.00 to 300.00 %</b>
Fixed inertia compensation set-up parameter.		
<b>VAR. INERTIA COMP</b>	<b>480</b>	<b>-300.00 to 300.00 %</b>
Variable inertia compensation set-up parameter.		
<b>ROLL WIDTH/MASS</b>	<b>481</b>	<b>0.00 to 100.00 %</b>
Scales the inertia fixed and variable compensations based on roll width. 100% = maximum roll width.		
<b>LINE SPEED SPT</b>	<b>498</b>	<b>-105.00 to 105.00 %</b>
Used to calculate the line speed acceleration rate value for the fixed and variable inertia compensations.		
<b>FILTER T.C.</b>	<b>482</b>	<b>0 to 20000</b>
The line speed acceleration rate value is calculated from the line speed input. The calculated rate value may have a large ripple content that can disturb the motor torque. The rate signal is therefore filtered, and this filter has a time constant set by this parameter.		
<b>RATE CAL</b>	<b>483</b>	<b>-100.00 to 100.00</b>
Scales the inertia compensation acceleration/deceleration rate value to 100% of the maximum line ramp rate. This parameter should be set to the maximum time required to ramp from zero to full speed in seconds. If RATE CAL = 0.00, then this parameter is set externally through NORMALISED dv/dt, otherwise, RATE CAL sets the inertia compensation acceleration/deceleration rate.		
<i>Note - Inertia compensation does not work well for line ramp rates above 100 seconds and therefore this parameter is limited to 100.00.</i>		
<b>NORMALISED dv/dt</b>	<b>484</b>	<b>-300.00 to 300.00 %</b>
Useful for large line ramp rates (>100 Secs). Tag an external signal to NORMALISED dv/dt to set the inertia compensation acceleration/deceleration rate externally from the drive. Useful for ramp rates exceeding 100 seconds. The external signal must be normalised to 100% = the maximum line ramp rate. Active <i>only</i> when RATE CAL = 0.00.		
<b>TENSION SCALER</b>	<b>486</b>	<b>-3.0000 to 3.0000</b>
Scales the TENSION DEMAND which is directly connected from the TAPER CALC. function block.		
<b>DIAMETER</b>	<b>427</b>	<b>—.xx %</b>
This is the output of the block.		
<b>MOD OF LINE SPEED</b>	<b>428</b>	<b>—.xx %</b>
Modulus of line speed.		
<b>MOD OF REEL SPEED</b>	<b>429</b>	<b>—.xx %</b>
Modulus of reel speed.		
<b>UNFILTERED DIAMETER</b>	<b>430</b>	<b>—.xx %</b>
Unfiltered value of “diameter” (before RAMP RATE filter).		
<b>TAPERED DEMAND</b>	<b>452</b>	<b>—.xx %</b>
This is the output of the TAPER calculation on the TENSION SPT (before adding TENSION TRIM).		

**MMI Menu Map**

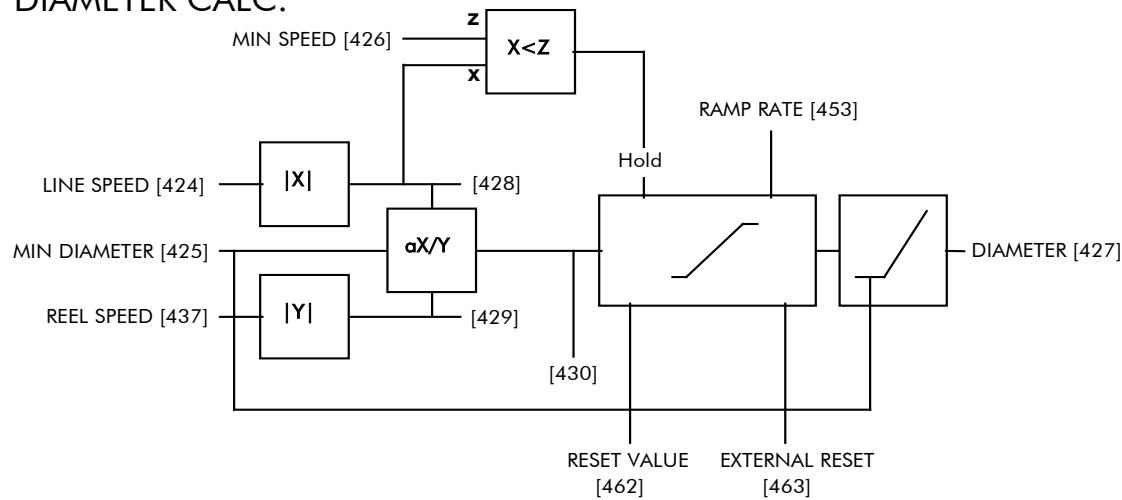
- 1 SETUP PARAMETERS
- 2 SPECIAL BLOCKS
- 3 TENS+COMP CALC.
  - STATIC COMP
  - DYNAMIC COMP
  - REWIND
  - FIX. INERTIA COMP
  - VAR. INERTIA COMP
  - ROLL WIDTH/MASS
  - LINE SPEED SPT
  - FILTER T.C.
  - RATE CAL
  - NORMALISED dv/dt
  - INERTIA COMP O/P
  - TENSION SCALER

**DIAMETER CALC.**

Parameter	Tag	Range
<b>TOT. TENS. DEMAND</b>	<b>441</b>	—. <b>xx</b> %
This is the final output of this block (total tension demand) which can be connected to the appropriate points in the block diagram.		
<b>INERTIA COMP O/P</b>	<b>485</b>	—. <b>xx</b> %
Monitors the sum of all inertia compensations.		
<b>OUTPUT</b>	<b>706</b>	—. <b>xx</b> %
The sum of the diameter-scaled TENSION DEMAND after the TENSION SCALER scaling and the compensation losses. For open loop winder applications, connect this output to the TORQUE DEMAND (Tag 432) in the TORQUE CALC. function block. (This output is located in the SYSTEM::CONFIGURE I/O::BLOCK DIAGRAM menu).		

**Functional Description**

**DIAMETER CALC.**

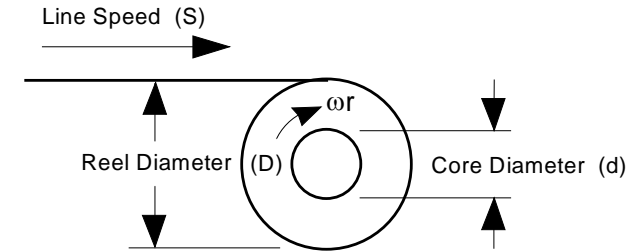


Circumference =  $\pi D$  or Line Speed (S) = Reel Speed ( $\omega r$ ) x D

Thus  $D = \frac{S}{\omega r}$

i.e.  $D \propto \frac{\text{Line Speed (S)}}{\text{Reel Speed } (\omega r)}$

Therefore with the web intact we can calculate the diameter from the two speeds.



## TAPER CALC

**Use this to profile the tension demand with diameter.**

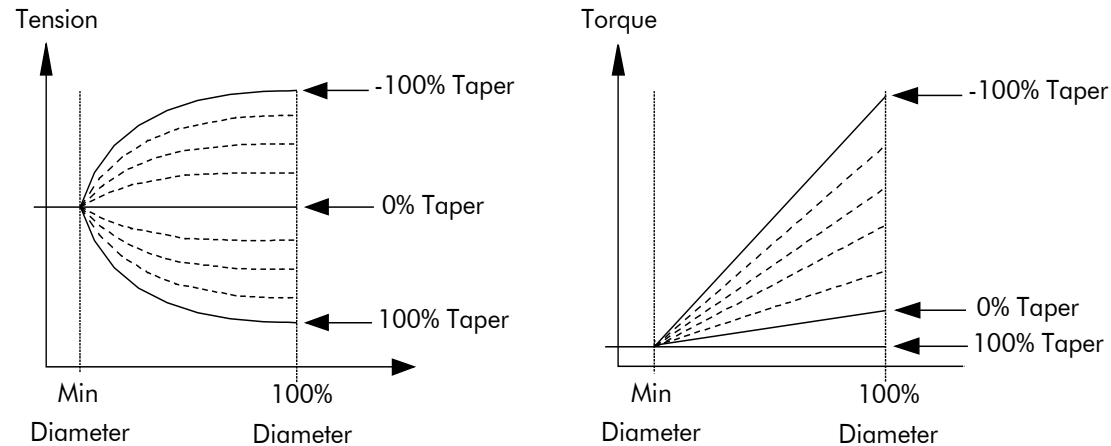
The function uses two inputs, tension setpoint and taper setpoint, to create the tension demand. The operator usually controls these setpoints.

Taper is a common requirement for winders. It reduces the tension as the roll diameter increases.

A profiler adjusts the tension using the equation:

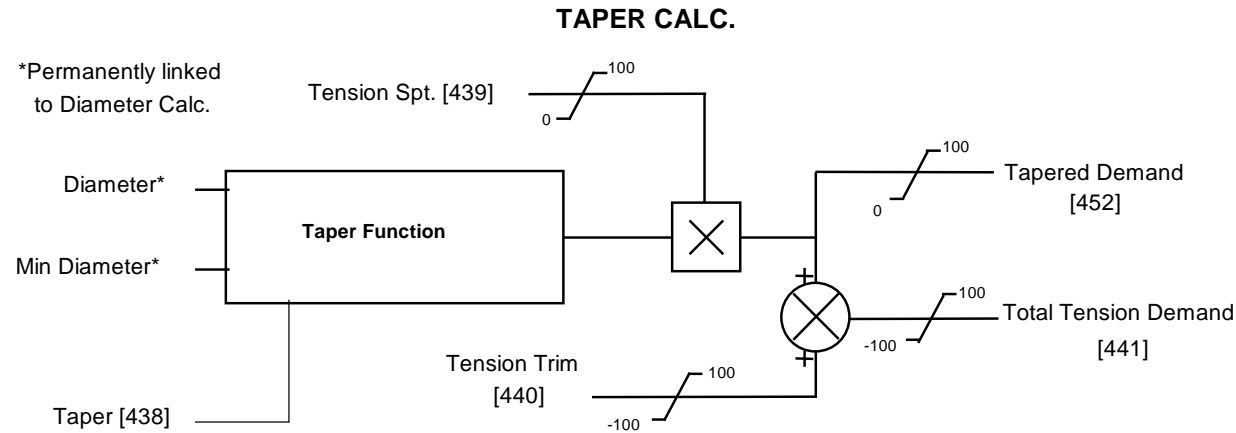
$$\text{Tapered Demand} = \text{Tension Spt} \times \left\{ 100\% - \frac{\text{Taper}}{\text{Diameter}} \times (\text{Diameter} - \text{Min Diameter}) \right\}$$

to yield a hyperbolic taper output. The taper tension characteristics are shown below:



The result is multiplied by TENSION SPT. to get TAPER DEMAND. When the taper setpoint is at 100%, the motor produces constant torque. That is, a constant torque from core to full roll, and the tension falls off as the roll builds.

TENSION TRIM allows the tension demand to be adjusted, for example, when using closed loop trim. The result is TOT. TENS DEMAND.



## TENS+COMP CALC

**This provides additional torque to compensate for static and dynamic friction, as well as the load inertia.**

Add these losses to the diameter-scaled tension demand to produce a compensated torque demand for open loop winder applications.

The inputs to this function are DIAMETER, TOT. TENS. DEMAND, and SPEED FEEDBACK from the SPEED LOOP function block.

For open loop winder applications, connect OUTPUT to TORQUE DEMAND (Tag 432) in the TORQUE CALC. function block.

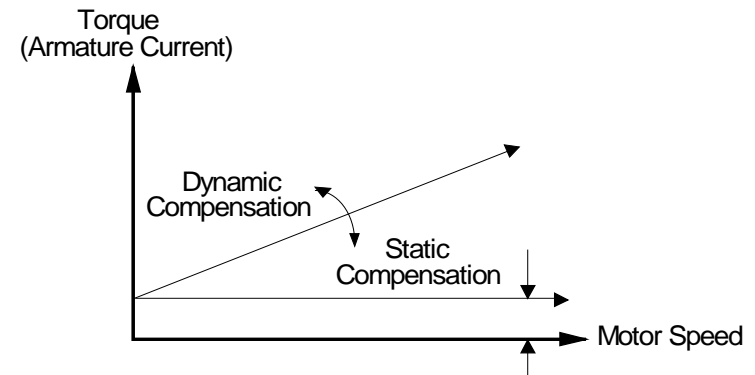
## Static and Dynamic Frictional Losses

Static and dynamic friction are due to gearbox resistance and mechanical binding in the winder spindle and motor bearings. Both absorb motor output torque and require compensation to maintain accurate winder tension.

Static friction, or "stiction", is a constant offset most noticeable at or near zero speed. The compensation torque required to overcome static friction is fixed over an entire operating speed range. You can ignore "stiction" for winders which do not normally operate at zero speeds.

Dynamic friction results from friction losses within the drive train, which includes gearboxes and chain belting linkages. The oil viscosity in gearboxes and windage losses in the motor armature fans also contribute to dynamic frictional losses.

The effects of static and dynamic friction are shown opposite.



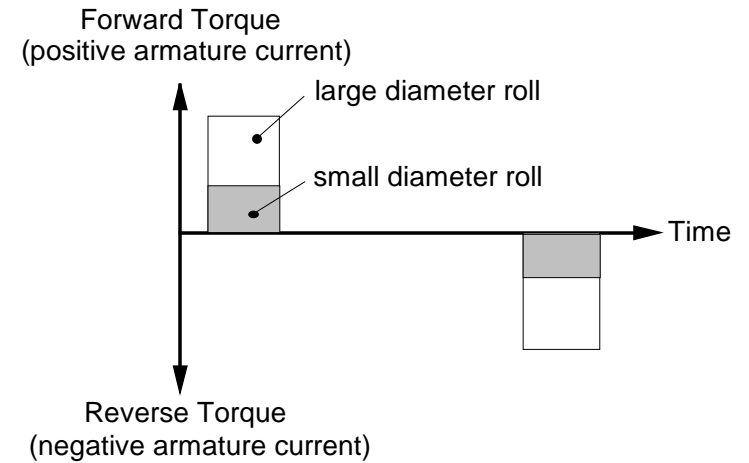
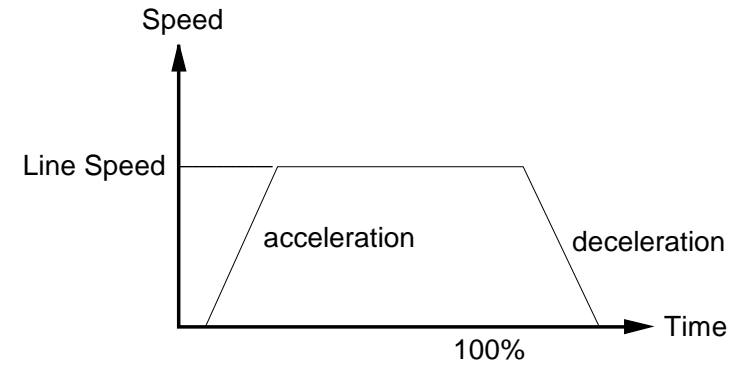
### Inertia Compensation

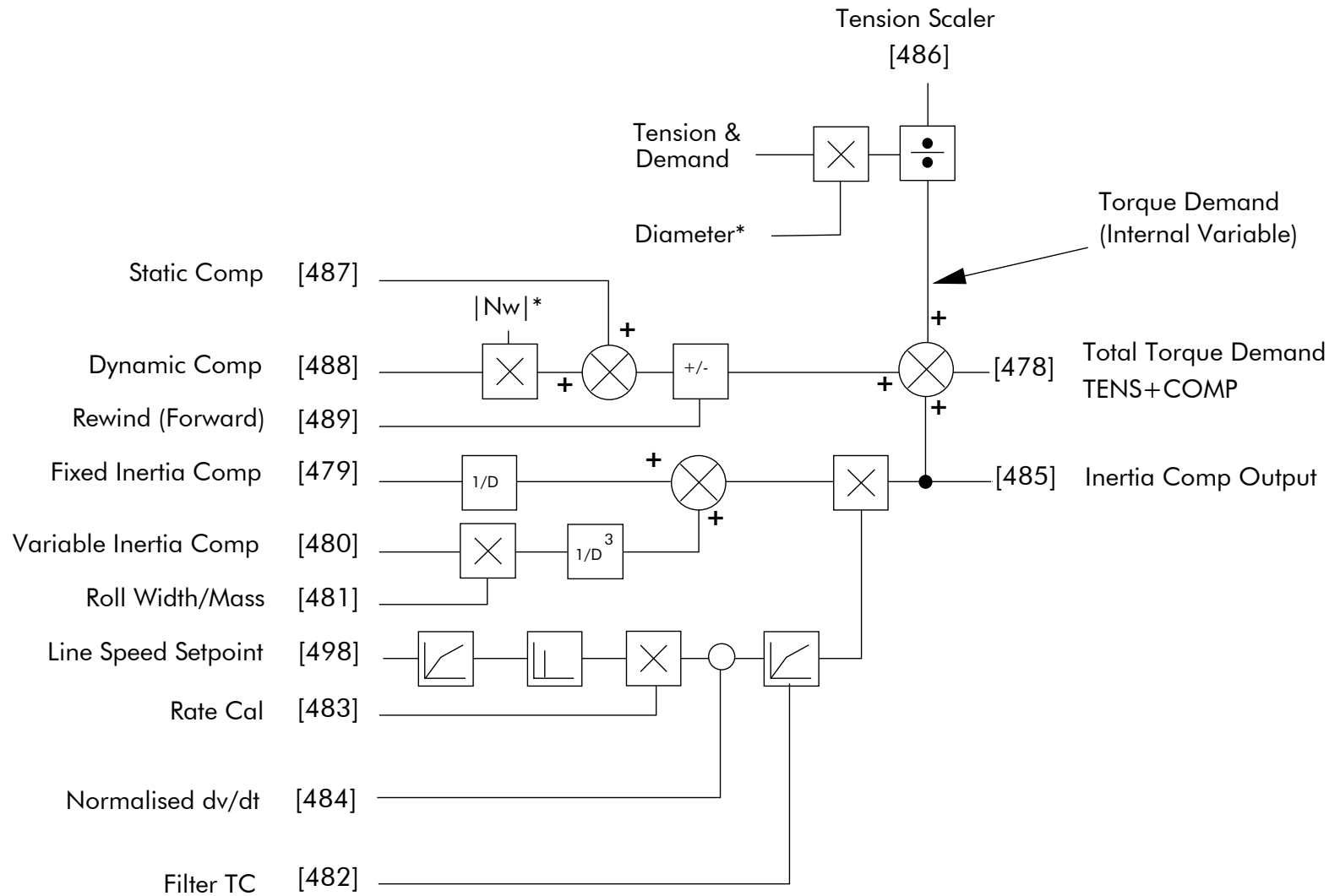
Many winders need inertia compensation to add or subtract torque during acceleration and deceleration to maintain constant tension, especially at large roll diameters. Without compensation, the tension holding capability of open loop winders diminishes during speed changes causing tension sag.

The inertia compensation characteristics is shown opposite.

For winder applications, inertia compensation is split into two components:

1. Fixed inertia compensation for the fixed motor, transmission and load components.
2. Variable inertia compensation for the changing roll inertia. This is especially necessary for high diameter build unwinds and winders.





& - Internally connected to Taper Calculator  
 \* - Internally connected to Diameter Calculator

**TENS + COMP Block Diagram**

**MMI Menu Map**

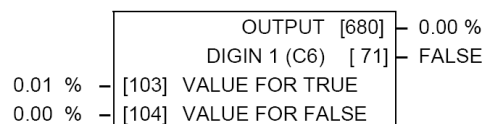
- 1 SYSTEM
- 2 CONFIGURE I/O
- 3 DIGITAL INPUTS
- 4 DIGIN 1 (C6)
- 4 DIGIN 2 (C7)
- 4 DIGIN 3 (C8)
- VALUE FOR TRUE
- VALUE FOR FALSE

# DIGITAL INPUTS

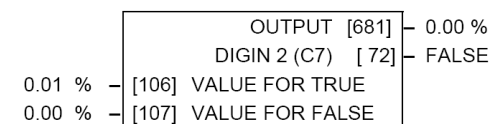
**Use this block to control the digital operating parameters of the software.**

The digital input can be configured to point to a destination location, and to set that destination TRUE or FALSE depending upon programmable values.

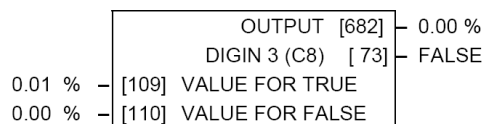
FUNCTION BLOCKS\INPUTS & OUTPUTS\DIGITAL INPUT\DIGITAL INPUT 1



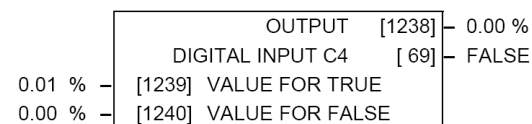
FUNCTION BLOCKS\INPUTS & OUTPUTS\DIGITAL INPUT\DIGITAL INPUT 2



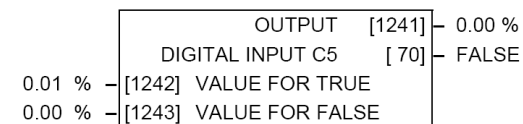
FUNCTION BLOCKS\INPUTS & OUTPUTS\DIGITAL INPUT\DIGITAL INPUT 3



FUNCTION BLOCKS\INPUTS & OUTPUTS\DIGITAL INPUT\DIGITAL INPUT 4



FUNCTION BLOCKS\INPUTS & OUTPUTS\DIGITAL INPUT\DIGITAL INPUT 5



## DIGITAL INPUTS

Parameter	Tag	Range
<b>VALUE FOR TRUE</b>	<b>103, 106, 109, 1239</b>	<b>-300.00 to 300.00 %</b>
The output value when input is TRUE, that is:		
Digital Input 1, terminal C6 = 24V (True)		
Digital Input 2, terminal C7 = 24V (True)		
Digital Input 3, terminal C8 = 24V (True)		
<b>VALUE FOR FALSE</b>	<b>104, 107, 110, 1240</b>	<b>-300.00 to 300.00 %</b>
The output value when input is FALSE, that is:		
Digital Input 1, terminal C6 = 0V (False)		
Digital Input 2, terminal C7 = 0V (False)		
Digital Input 3, terminal C8 = 0V (False)		
<b>OUTPUT</b>	<b>680, 681, 682, 1238</b>	<b>—,xx %</b>
The output value, this is either VALUE FOR TRUE or VALUE FOR FALSE.		
<b>DIGIN 1 (C6) to DIGITAL INPUT C5</b>	<b>71, 72, 73, 69</b>	<b>OFF / ON</b>
The Boolean representation of the actual voltage applied to the terminal.		

## Digital Input Examples

### Using Digital Inputs with LOGIC Parameters

Logic parameters have values of 1/0: TRUE/FALSE, ON/OFF, ENABLED/DISABLED etc.

For example, the default connections in the drive allow the Digital Inputs to switch LOGIC parameters. These are the connections from:

- Terminal C6 to Tag 90 (BIPOLAR CLAMPS)
- Terminal C7 to Tag 118 (RAMP HOLD)
- Terminal C8 to Tag 119 (I DMD. ISOLATE)

In each case, the state of the terminal (24V or 0V) switches the destination parameter by sending a 1 or 0.

The format for the VALUE FOR TRUE and VALUE FOR FALSE parameters is in percent, thus 0.00% = 0 and 0.01% (or any other non-zero positive number) = 1.

### *Inverting the Input Signal*

The default setting is for VALUE FOR TRUE to be 0.01% and VALUE FOR FALSE to be 0.00%. Inverting the digital input is therefore simple; set VALUE FOR TRUE to 0.00% and VALUE FOR FALSE to 0.01% (or any other non-zero number).

To do this:

1. Set CONFIGURE I/O::CONFIGURE ENABLE to TRUE
2. Set DIGIN 1 (C6)::VALUE FOR TRUE to 0.00%
3. Set VALUE FOR FALSE to 0.01%
4. Reset CONFIGURE I/O::CONFIGURE ENABLE to FALSE

Digital Input 1 now sends a 0 when the input signal is TRUE, and 1 when it is FALSE.

### Using Digital Inputs with VALUE Parameters

Value parameters have values such as 100.00, or with units like 50.00%, 10.0 SECS etc.

You can use a Digital Input to send two fixed values to a VALUE parameter depending upon the state of the input terminal, 24V or 0V. You set the two fixed values you require in the VALUE FOR TRUE and VALUE FOR FALSE parameters.



For example, to connect Digital Input 1 to SPEED LOOP::SPD.PROP.GAIN :

1. Set CONFIGURE I/O::CONFIGURE ENABLE to TRUE
2. Find the tag number for SPD.PROP.GAIN either from the function block detail in this chapter, or from the Parameter Table: MMI Order - refer to Appendix C. (It is 14).
3. Set DIGIN 1 (C6)::DESTINATION TAG to 14
4. Set VALUE FOR TRUE to 10.00%
5. Set VALUE FOR FALSE to 30.00%
6. Reset CONFIGURE I/O::CONFIGURE ENABLE to FALSE

Digital Input 1 will now set SPD.PROP.GAIN to two values depending upon the state of the input signal:

- When the input terminal is at 24V, SPD.PROP.GAIN is set to 10.00
- When the input terminal is at 0V, SPD.PROP.GAIN is set to 30.00

## DIGITAL INPUT C5

### Caution

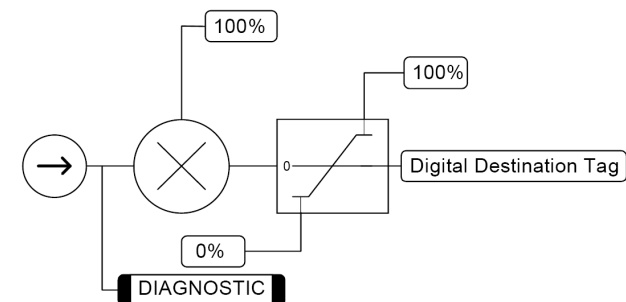
If you are isolating power on the drive output using a DC contactor, you must use an auxiliary, normally-open contact connected to terminal C5 to immediately disable the drive's current loop when the contactor coil de-energises. Free-up terminal C5 for other uses **only** when isolating main power on the input side of the drive using an AC contactor.

**NOTE** Some 590 DRV models isolate power on the 590 drive output using a DC contactor, so you cannot use terminal C5 as an additional digital input.

## Additional Digital Inputs

It is possible to use an Analog Input as a Digital Input to extend the number of Digital Inputs available. Again, 0.00% is regarded as Logic 0 and 0.01% (or any other non-zero positive value) is regarded as Logic 1.

### Using Analog I/P as Digital I/P



**MMI Menu Map**

- 1 SYSTEM
- 2 CONFIGURE I/O
- 3 DIGITAL OUTPUTS
- 4 DIGOUT 1 (B5)
- 4 DIGOUT 2 (B6)
- 4 DIGOUT 3 (B7)
  - \_ THRESHOLD (>)
  - \_ MODULUS
  - \_ SOURCE TAG
  - \_ INVERTED

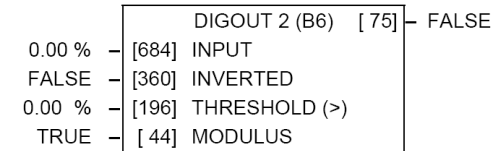
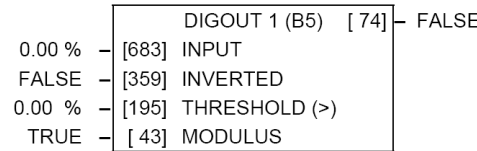
# DIGITAL OUTPUTS

**These function block allows you to output digital parameters within the software to other**

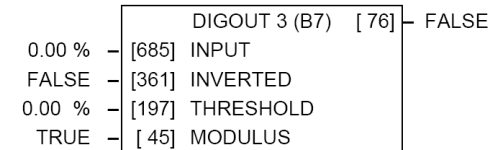
**equipment.**

A digital output can be configured to point to any digital value within the software system and to output information depending upon the status of that value.

FUNCTION BLOCKS\INPUTS & OUTPUTS\DIGITAL OUTPUT\DIGITAL OUTPUT 1      FUNCTION BLOCKS\INPUTS & OUTPUTS\DIGITAL OUTPUT\DIGITAL OUTPUT 2



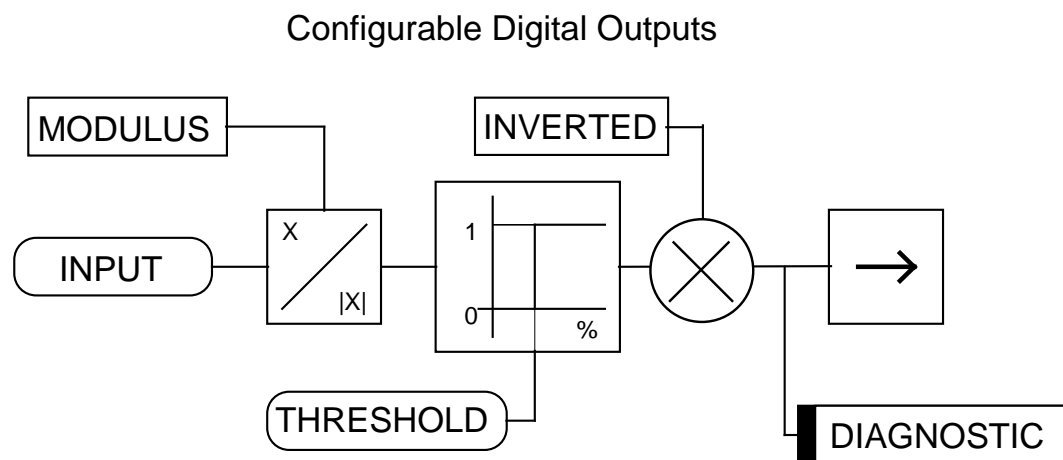
FUNCTION BLOCKS\INPUTS & OUTPUTS\DIGITAL OUTPUT\DIGITAL OUTPUT 3



## DIGITAL OUTPUTS

Parameter	Tag	Range
<b>INPUT</b> The unprocessed value to output.	<b>683, 684, 685</b>	<b>—.xx %</b>
<b>INVERTED</b> Selects to invert the output when TRUE.	<b>359, 360, 361</b>	<b>FALSE / TRUE</b>
<b>THRESHOLD</b> (THRESHOLD (>)) The threshold which the input value must exceed to set the output to TRUE.	<b>195, 196, 197</b>	<b>-300.00 to 300.00 %</b>
<b>MODULUS</b> When TRUE, the absolute value of INPUT is used for the threshold test.	<b>43, 44, 45</b>	<b>FALSE / TRUE</b>
<b>DIGOUT 1 (B5) to DIGOUT 3 (B7)</b> The actual Boolean value sent to the output terminal.	<b>74, 75, 76</b>	<b>OFF / ON</b>

## Functional Description



## Digital Output Examples

### Using Digital Outputs with LOGIC Parameters

Logic parameters have values of 1/0: TRUE/FALSE, ON/OFF, ENABLED/DISABLED etc.

For example, the (logic) default connections in the drive allow the Digital Outputs to provide (source) 24V or 0V dc depending upon the state of following tag connections:

- Terminal B5, Digital Output 1 is linked to Tag Number 77 (AT ZERO SPEED)
- Terminal B6, Digital Output 2 is linked to Tag Number 122 (HEALTH LED)
- Terminal B7, Digital Output 3 is linked to Tag Number 125 (READY)

In each case, the state of the source parameter defines the voltage available at the terminal (TRUE = 24V, FALSE = 0V when INVERTED = FALSE). Inverting the digital output is simple; set INVERTED to TRUE.

## Using Digital Outputs with VALUE Parameters (Up-to-speed Detector)

Value parameters have values such as 100.00, or with units like 50.00%, 10.0 SECS etc.

For example, to connect Digital Output 1 to read UNFIL.SPD.FBK:

1. Set CONFIGURE I/O::CONFIGURE ENABLE to TRUE
2. Find the tag number for UNFIL.SPD.FBK either from the function block detail in this chapter, or from the Parameter Table: MMI Order - refer to Appendix C. (It is 62).
3. Set DIGITAL OUTPUTS::DIGOUT 1 (B5)::SOURCE TAG to 62
4. Set DIGITAL OUTPUTS::DIGOUT 1 (B5)::THRESHOLD(>) to 50.00%
5. Set DIGITAL OUTPUTS::DIGOUT 1 (B5)::MODULUS to TRUE
6. Set DIGITAL OUTPUTS::DIGOUT 1 (B5)::INVERTED to FALSE
7. Set CONFIGURE I/O::CONFIGURE ENABLE to FALSE

This option is useful for generating an "up-to-speed" output. The MODULUS removes the sign from the value (so -100 becomes 100). The THRESHOLD(>) parameter determines when the output is 24V or 0V dc (the input signal must exceed this setting for the output to go high). Set INVERTED to TRUE to invert the result of the output.

## DRIVE INFO

This block provides information to identify the drive hardware and firmware version.

### MMI Menu Map

- 1 SERIAL LINKS
- 2 SYSTEM PORT (P3)
- VERSION NUMBER

### MMI Menu Map

- 1 FUNCTION BLOCKS
- 2 MISCELLANEOUS
- 3 DRIVE INFO
  - PCODE ID
  - PRODUCT CODE
  - FRAME ID

FUNCTION BLOCKS MISCELLANEOUS DRIVE INFO

PRODUCT CODE	[510]	-1
FRAME ID	[626]	-0
VERSION NUMBER	[155]	-0x0000
1 - [545] PCODE ID		

## DRIVE INFO

Parameter	Tag	Range
-----------	-----	-------

**PCODE ID** **545** **0 to 100**

The product code. This representation is guaranteed to be unchanged between different software versions.

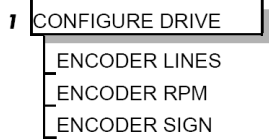
0: INVALID	71: DC 4Q 35A D	27: DC 4Q 450A D	45: DC 4Q 2200A 40 D	65: DC RETRO 4Q 720A
1: DC 4Q 15A	72: DC 2Q 35A D	28: DC 2Q 450A D	46: DC 2Q 2200A 40 D	66: DC RETRO 2Q 720A
2: DC 2Q 15A	73: DC 4Q 70A D	29: DC 4Q 720A D	47: DC 4Q 2700A 40 D	67: DC RETRO 4Q 128A
3: DC 4Q 35A	74: DC 2Q 70A D	30: DC 2Q 720A D	48: DC 2Q 2700A 40 D	68: DC RETRO 2Q 128A
4: DC 2Q 35A	75: DC 4Q 110A D	31: DC 4Q 800A D	49: DC 4Q 1200A 60 D	69: DC HW SCALE 4Q D
5: DC 4Q 40A	76: DC 2Q 110A D	32: DC 2Q 800A D	50: DC 2Q 1200A 60 D	70: DC HW SCALE 2Q D
6: DC 2Q 40A	77: DC 4Q 150A D	85: DC 4Q 1024* 30*D	51: DC 4Q 1700A 60 D	87: DC 2Q 40A
7: DC 4Q 55A	78: DC 2Q 150A D	86: DC 2Q 1024* 30*D	52: DC 2Q 1700A 60 D	88: DC 4Q 40A
8: DC 2Q 55A	21: DC 4Q 180A D	33: DC 4Q 1200A 20 D	53: DC 4Q 2200A 60 D	89: DC 4Q 725A
9: DC 4Q 70A	22: DC 2Q 180A D	34: DC 2Q 1200A 20 D	54: DC 2Q 2200A 60 D	90: DC 2Q 725A
10: DC 2Q 70A	23: DC 4Q 270A D	35: DC 4Q 1700A 20 D	55: DC 4Q 2700A 60 D	91: DC 4Q 830A
11: DC 4Q 90A	24: DC 2Q 270A D	36: DC 2Q 1700A 20 D	56: DC 2Q 2700A 60 D	92: DC 2Q 830A
12: DC 2Q 90A	79: DC 4Q 128* 20* D	37: DC 4Q 2200A 20 D	57: DC 4Q 1200A 80 D	93: DC 4Q 1580A
13: DC 4Q 110A	80: DC 2Q 128* 20* D	38: DC 2Q 2200A 20 D	58: DC 2Q 1200A 80 D	94: DC 2Q 1580A
14: DC 2Q 110A	81: DC 4Q 1024* 20*D	39: DC 4Q 2700A 20 D	59: DC 4Q 1700A 80 D	95: DC 4Q 275A
15: DC 4Q 125A	82: DC 2Q 1024* 20*D	40: DC 2Q 2700A 20 D	60: DC 2Q 1700A 80 D	96: DC 2Q 275A
16: DC 2Q 125A	83: DC 4Q 1024* 30*D	41: DC 4Q 1200A 40 D	61: DC 4Q 2200A 80 D	97: DC 4Q 380A
17: DC 4Q 162A	84: DC 2Q 1024* 30*D	42: DC 2Q 1200A 40 D	62: DC 2Q 2200A 80 D	98: DC 2Q 380A
18: DC 2Q 162A	25: DC 4Q 360A D	43: DC 4Q 1700A 40 D	63: DC 4Q 2700A 80 D	99: DC 4Q 500A
19: DC 4Q 165A	26: DC 2Q 360A D	44: DC 2Q 1700A 40 D	64: DC 2Q 2700A 80 D	100: DC 2Q 500A
20: DC 2Q 165A				

**DRIVE INFO**

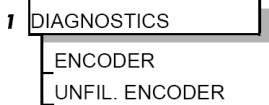
Parameter	Tag	Range
<b>PRODUCT CODE</b>	<b>510</b>	<b>0 to 96</b>
An internal representation of the product code. This representation may change between software versions.		
0: INVALID	21: DC 4Q 35A D	41: DC 4Q 450A D
1: DC 4Q 15A	22: DC 2Q 35A D	42: DC 2Q 450A D
2: DC 2Q 15A	23: DC 4Q 70A D	43: DC 4Q 720A D
3: DC 4Q 35A	24: DC 2Q 70A D	44: DC 2Q 720A D
4: DC 2Q 35A	25: DC 4Q 110A D	45: DC 4Q 800A D
5: DC 4Q 40A	26: DC 2Q 110A D	46: DC 2Q 800A D
6: DC 2Q 40A	27: DC 4Q 150A D	47: DC 4Q 1024* 30*D
7: DC 4Q 55A	28: DC 2Q 150A D	48: DC 2Q 1024* 30*D
8: DC 2Q 55A	29: DC 4Q 180A D	49: DC 4Q 1200A 20 D
9: DC 4Q 70A	30: DC 2Q 180A D	50: DC 2Q 1200A 20 D
10: DC 2Q 70A	31: DC 4Q 270A D	51: DC 4Q 1700A 20 D
11: DC 4Q 90A	32: DC 2Q 270A D	52: DC 2Q 1700A 20 D
12: DC 2Q 90A	33: DC 4Q 128* 20* D	53: DC 4Q 2200A 20 D
13: DC 4Q 110A	34: DC 2Q 128* 20* D	54: DC 2Q 2200A 20 D
14: DC 2Q 110A	35: DC 4Q 1024* 20*D	55: DC 4Q 2700A 20 D
15: DC 4Q 125A	36: DC 2Q 1024* 20*D	56: DC 2Q 2700A 20 D
16: DC 2Q 125A	37: DC 4Q 1024* 30*D	57: DC 4Q 1200A 40 D
17: DC 4Q 162A	38: DC 2Q 1024* 30*D	58: DC 2Q 1200A 40 D
18: DC 2Q 162A	39: DC 4Q 360A D	59: DC 4Q 1700A 40 D
19: DC 4Q 165A	40: DC 2Q 360A D	60: DC 2Q 1700A 40 D
20: DC 2Q 165A		61: DC 4Q 2200A 40 D
		62: DC 2Q 2200A 40 D
		63: DC 4Q 2700A 40 D
		64: DC 2Q 2700A 40 D
		65: DC 4Q 1200A 60 D
		66: DC 2Q 1200A 60 D
		67: DC 4Q 1700A 60 D
		68: DC 2Q 1700A 60 D
		69: DC 4Q 2200A 60 D
		70: DC 2Q 2200A 60 D
		71: DC 4Q 2700A 60 D
		72: DC 2Q 2700A 60 D
		73: DC 4Q 1200A 80 D
		74: DC 2Q 1200A 80 D
		75: DC 4Q 1700A 80 D
		76: DC 2Q 1700A 80 D
		77: DC 4Q 2200A 80 D
		78: DC 2Q 2200A 80 D
		79: DC 4Q 2700A 80 D
		80: DC 2Q 2700A 80 D
		81: DC RETRO 4Q 128A
		82: DC RETRO 2Q 128A
		83: DC 2Q 40A
		84: DC 4Q 40A
		85: DC 4Q 725A
		86: DC 2Q 725A
		87: DC 4Q 830A
		88: DC 2Q 830A
		89: DC 4Q 1580A
		90: DC 2Q 1580A
		91: DC 4Q 275A
		92: DC 2Q 275A
		93: DC 4Q 380A
		94: DC 2Q 380A
		95: DC 4Q 500A
		96: DC 2Q 500A
<b>FRAME ID</b>	<b>626</b>	<b>—</b>
An internal representation of the frame size.		
<b>VERSION NUMBER</b>	<b>155</b>	<b>0x0801</b>
The drive's version number as seen via communications. Version 8.01 is represented as 0x0801.		
Serial communications mnemonic = V0. The version number cannot be changed, and is software version dependent.		

## ENCODER

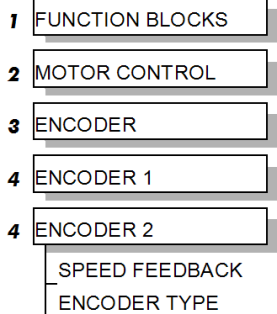
### MMI Menu Map (from ENCODER 1)



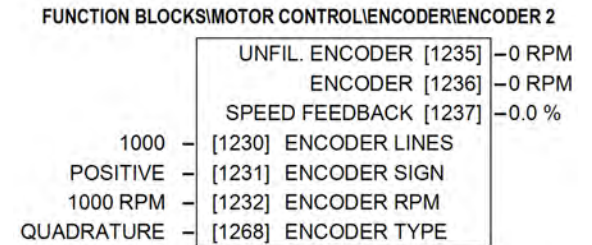
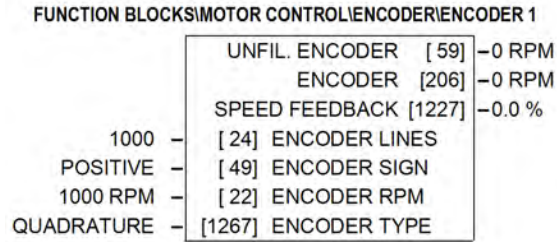
### MMI Menu Map (from ENCODER 1)



### MMI Menu Map



This block allows the Speed Feedback to be measured using a quadrature encoder when a Speed Feedback Option is fitted - refer to Chapter 3: Speed Feedback and Technology Options.



The ENCODER 1 function block is associated with the speed feedback option.

The ENCODER 2 function block is associated with Digital Input 2 (terminal C7) and Digital Input 3 (terminal C8) where:

- Digital Input 2 provides the clock.
- Digital Input 3 is used as a direction input.

## ENCODER

Parameter	Tag	Range
<b>ENCODER LINES</b>	<b>24, 1230</b>	<b>10 to 5000</b>
The number of lines must be set to match the type of encoder being used. Incorrect setting of this parameter will result in an erroneous speed measurement. The 5901 Microtach has 1000 lines per revolution as standard. Proprietary encoders of other specifications can be normalised by setting this parameter as appropriate.		
<b>ENCODER SIGN</b>	<b>49, 1231</b>	<b>NEGATIVE / POSITIVE</b>
Since the encoder feedback cannot be reversed electrically, the signal polarity can be reversed by the control software. <i>It is necessary to set up this parameter when in CLOSED-LOOP VEC mode, as the encoder direction must be correct for this mode to operate.</i>		
<b>ENCODER RPM</b>	<b>22, 1232</b>	<b>0 to 6000</b>
Motor top speed setting (100%) when using encoder feedback.		
<b>UNFIL. ENCODER</b>	<b>59, 1235</b>	<b>— RPM</b>
Unfiltered encoder speed in RPM		
<b>ENCODER</b>	<b>206, 1236</b>	<b>— RPM</b>
Encoder speed in RPM		
<b>SPEED FEEDBACK</b>	<b>1227, 1237</b>	<b>—x %</b>
Encoder speed in %. A speed of 100% indicates that the encoder is rotating at the value set in the ENCODER RPM parameter.		

**ENCODER**

Parameter	Tag	Range
<b>ENCODER TYPE</b>	<b>1267, 1268</b>	<b>See below</b>



Selects the operating mode of the encoder input. Both of these encoder function blocks can be used in either QUADRATURE or CLOCK/DIRECTION modes of operation. When in CLOCK/DIRECTION mode, the CLOCK input is applied to terminal A on the speed feedback option (for ENCODER 1) or to Digital Input 2 (for ENCODER 2), and every rising edge of the CLOCK is counted.

0 : CLOCK/DIRECTION  
1 : QUADRATURE

**Functional Description**

**You must configure Digital Input 2 and 3** which, by default, provide "Ramp Hold" and "Current Demand Isolate" functionality. In the default configuration they are linked using LINK 21 and LINK 22 respectively. The Encoder blocks are connected to terminals C7 and C8 internally and thus don't require these links. Use the Configurator Tool to delete the links.

Alternatively when the default configuration is loaded, this can be done using the Keypad as shown below:

Navigate to the SYSTEM::CONFIGURE I/O menu. Select the CONFIGURE ENABLE parameter and set to ENABLED. All LEDs on the Keypad will flash. Press the  key. Use the  key to navigate to the DIGITAL INPUTS menu.

In this menu, select the DIGIN 2 (C7) menu. Navigate to the DESTINATION TAG parameter and set this value to 0 (zero). Repeat this operation for the DIGIN 3 (C8) parameter.

Remember to perform a Parameter Save.

***ENCODER TYPE = CLOCK/DIRECTION***

This (pulse-counting mode) Encoder Type can be set in the ENCODER 2 function block only.

Digital Input 2 (terminal C7) is used to provide the clock - the pulses are applied on C7

Digital Input 3 (terminal C8) is used as a direction input:

- When C8 is high, (24V), the count is incremented
- When C8 is low, (0V), the count is decremented

Each full pulse received increments the encoder count.

A full pulse is the pulse input going from low to high, and then back to low.

Speed is calculated using the following function:

$$\text{SPEED HZ} = \text{filter} \left[ \frac{\text{CountsPerSecond}}{\text{Lines}}, \text{FilterTime} \right]$$



## ***ENCODER TYPE = QUADRATURE***

A quadrature encoder uses 2 input signals (A and B), phase shifted by a quarter of a cycle (90°).

Digital input 2, (C7) = Encoder A phase

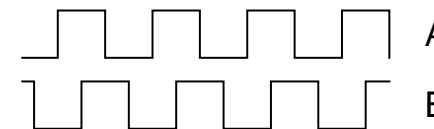
Digital input 3, (C8) = Encoder B phase

Direction is obtained by looking at the combined state of A and B.

Each edge received from the encoder increments the encoder count. There are 4 counts per line.

Speed is calculated using the following function:

$$\text{SPEED HZ} = \text{filter} \left[ \frac{\text{CountsPerSecond}}{\text{Lines} \times 4}, \text{FilterTime} \right]$$



**MMI Menu Map**

1	DIAGNOSTICS
	SPEED FEEDBACK
	CURRENT FEEDBACK
	UNFIL.FIELD FBK
	ARM VOLTS FBK
	TACH INPUT

## FEEDBACKS

Diagnostics for the motor feedbacks.

FUNCTION BLOCKSMOTOR CONTROL\FEEDBACKS

ARM VOLTS FBK	[605]	0 V
UNFIL.FIELD FBK	[181]	0.00 %
SPEED FEEDBACK	[207]	0.00 %
CURRENT FEEDBACK	[298]	0.00 %
TACH INPUT	[308]	0.0 %

## FEEDBACKS

Parameter	Tag	Range
<b>ARM VOLTS FBK</b>	<b>605</b>	<b>—.x V</b>
Back EMF scaled by NOM MOTOR VOLTS.		
<b>UNFIL.FIELD FBK</b>	<b>181</b>	<b>—.xx %</b>
Scaled field current feedback		
<b>SPEED FEEDBACK</b>	<b>207</b>	<b>—.xx %</b>
Speed feedback.		
<b>CURRENT FEEDBACK</b>	<b>298</b>	<b>—.xx %</b>
Scaled and filtered armature current feedback.		
<b>TACH INPUT</b>	<b>308</b>	<b>—.x %</b>
Scaled analog tachogenerator feedback.		

## FIELD CONTROL

### MMI Menu Map

- 1 SETUP PARAMETERS
- 2 FIELD CONTROL
  - FIELD ENABLE
  - FLD.CTRL MODE
  - FIELD I THRESH
  - UP TO FIELD
  - >> FLD.VOLTAGE VARS
  - >> FLD.CURRENT VARS
  - FLD.QUENCH DELAY
  - FLD. QUENCH MODE

**This function block contains all the parameters for the field operating mode.**

It controls the drive's full wave, single phase, motor field thyristor bridge circuit.

The FIELD CONTROL function block is viewed in three sub-menus on the MMI: FLD VOLTAGE VARS, FLD CURRENT VARS and FLD WEAK VARS.

In the FIELD CONTROL menu, you select the field operating mode: open loop voltage control or closed loop current control.

The inputs to the FIELD CONTROL block come from FLD VOLTAGE VARS and FLD CURRENT VARS.

FIELD ENABLE controls the field thyristor bridge and is set to DISABLED in permanent field motor applications. Disabling the field automatically overrides the field fail alarm. If FIELD ENABLE is enabled, you can select between voltage and current control using the FLD CTRL MODE parameter. The default is VOLTAGE CONTROL.

The diagnostic DRIVE ENABLE (Tag 84) is also used by the FLD. QUENCH DELAY to delay disabling the field when Run is removed.

### MMI Menu Map

- 1 SETUP PARAMETERS
- 2 FIELD CONTROL
- 3 FLD.VOLTAGE VARS
  - FLD.VOLTS RATIO

### FLD VOLTAGE VARS : MMI Sub-Menu

Contains the parameter for the open loop VOLTAGE CONTROL mode.

In VOLTAGE CONTROL mode, set the value of FLD.VOLTS RATIO to provide the correct field voltage. This control mode provides open-loop phase angle control of the thyristor bridge. To calculate FLD.VOLTS RATIO, divide the desired DC field voltage by the line-to-line RMS AC input voltage and multiply by 100. Note that supply voltage variations are not compensated for in the field supply when in this mode of operation.

### MMI Menu Map

- 1 SETUP PARAMETERS
- 2 FIELD CONTROL
- 3 FLD.CURRENT VARS
  - SETPOINT
  - PROP. GAIN
  - INT. GAIN
  - >> FLD.WEAK VARS

### FLD CURRENT VARS : MMI Sub-Menu

Contains the parameters for the closed loop current control mode.

CURRENT CONTROL mode uses actual field current feedback for closed-loop control giving accurate motor field control independent of motor temperature. This mode makes use of a simple PI controller and is a pre-requisite for field weakening.

### FUNCTION BLOCKS/MOTOR CONTROL/FIELD CONTROL

	FIELD ENABLE	[169]	DISABLED
	FIELD DEMAND	[183]	0.00 %
	FLD.FIRING ANGLE	[184]	0.00 DEG
	FIELD I FBK	[300]	0.00 %
	FIELD I FBK.AMPS	[539]	0.0 A
	UP TO FIELD	[618]	FALSE
	WEAK PID ERROR	[1185]	0.00 %
	WEAK PID OUT	[1186]	0.00 %
	FIELD STATE	[1187]	FIELD INIT
	BEMF INPUT	[1274]	0.00 %
ENABLED	-	[170]	FIELD ENABLE
100.00 %	-	[171]	SETPOINT
0.10	-	[173]	PROP. GAIN
1.28	-	[172]	INT. GAIN
DISABLED	-	[174]	FLD. WEAK ENABLE
2.00	-	[175]	EMF LEAD
40.00	-	[176]	EMF LAG
0.30	-	[177]	EMF GAIN
90.00 %	-	[179]	MIN FLD.CURRENT
100.00 %	-	[178]	MAX VOLTS
100	-	[191]	BEMF FBK LEAD
100	-	[192]	BEMF FBK LAG
0.0 s	-	[185]	FLD.QUENCH DELAY
QUENCH	-	[186]	FLD.QUENCH MODE
80.00 %	-	[617]	FIELD I THRESH
VOLTAGE CONTROL	-	[209]	FLD. CTRL MODE
90.0%	-	[210]	FLD.VOLTS RATIO
LOCAL BEMF	-	[1273]	BEMF SOURCE

## FLD WEAK VARS : MMI Sub-Menu

In certain applications of a DC motor controller, high speeds can only be achieved by reducing the field current and therefore the resultant torque. This is termed as the Constant-Horsepower region or Field-Weakening region, and the speed at which it begins is known as the Base Speed.

### MMI Menu Map

- 1 SETUP PARAMETERS
- 2 FIELD CONTROL
- 3 FLD.CURRENT VARS
- 4 FLD.WEAK VARS
  - FLD. WEAK ENABLE
  - EMF LEAD
  - EMF LAG
  - EMF GAIN
  - MIN FLD.CURRENT
  - MAX VOLTS
  - BEMF FBK LEAD
  - BEMF FBK LAG

### FIELD CONTROL

Parameter	Tag	Range
<b>FIELD ENABLE</b> Enables and disables the drive motor Field Control.	<b>170</b>	<b>DISABLED / ENABLED</b>
<b>SETPOINT</b> Field current setpoint as percentage of calibrated value.	<b>171</b>	<b>0.00 to 100.00 %</b>
<b>PROP. GAIN</b> This is the proportional gain adjustment of the field current PI loop. The default of 0.10 is equivalent to a real gain of 10.	<b>173</b>	<b>0.00 to 100.00</b>
<b>INT. GAIN</b> This is the integral gain adjustment of the field current PI loop.	<b>172</b>	<b>0.00 to 100.00</b>
<b>FLD. WEAK ENABLE</b> Activates the additional motor back-emf, gain-limited PI loop for field weakening (field spillover) control. STANDARD mode uses the control loop to convert the back-emf in excess of the MAX VOLTS setting, into a reduction of the demanded field current. ADVANCED mode also adds in a feedforward control term, based on a comparison of the speed feedback to the calculated base speed, and uses adaptive gain, in both the back-emf and speed control loops, to compensate for the gain effects of reduced field operation.	<b>174</b>	<b>DISABLED/STANDARD/ADVANCED</b>
<b>EMF LEAD</b> With field weakening control enabled, a gain-limited PI loop is brought into operation. This is the lead time constant adjustment of the field weakening PI loop. With a default of 2.00, real time constant = 200ms. Refer to Chapter 5: "Control Loops" for details of Tuning.	<b>175</b>	<b>0.10 to 50.00</b>
<b>EMF LAG</b> This is the lag time constant adjustment of the field weakening PI loop. With a default of 40.00, real time constant = 4000ms. Refer to Chapter 5: "Control Loops" for details of Tuning.	<b>176</b>	<b>0.00 to 200.00</b>
<b>EMF GAIN</b> This is the steady-state gain adjustment of the field weakening PI loop. With a default of 0.30, real gain = 30. Refer to Chapter 5: "Control Loops" for details of Tuning.	<b>177</b>	<b>0.00 to 100.00</b>

### MMI Menu Map

- 1 DIAGNOSTICS
  - FIELD ENABLED
  - FIELD DEMAND
  - FIELD I FBK
  - FIELD I FBK.AMPS
  - FLD.FIRING ANGLE

### MMI Menu Map

- 1 FUNCTION BLOCKS
- 2 MOTOR CONTROL
- 3 FIELD CONTROL
  - WEAK PID ERROR
  - WEAK PID OUT
  - FIELD STATE
  - BEMF SOURCE
  - BEMF INPUT

<b>FIELD CONTROL</b>		
<b>Parameter</b>	<b>Tag</b>	<b>Range</b>
<b>MIN FLD. CURRENT</b>	<b>179</b>	<b>0.00 to 100.00 %</b>
Protects against motor overspeeding due to unintended excessive field weakening. The field weakening loop reduces the field current to achieve speed control above base speed. At top speed the field reaches a minimum value. MIN FIELD CURRENT should be set below this minimum value to allow reasonable margin for transient control near the top speed but not lower than 6% as this could then cause the "Field Fail" alarm to operate.		
<b>MAX VOLTS</b>	<b>178</b>	<b>0.00 to 100.00 %</b>
Maximum volts is the back-emf voltage level at which field weakening begins. It is also known as "Spillover Bias". The default value is 100% of the nominal value as set by the armature voltage calibration value. This value might be reduced due to the known IR drop included in the armature voltage calibration value. Additionally for commissioning purposes, this value may be set to another (lower) desirable level, and subsequently returned to the original value.		
<b>BEMF FBK LEAD</b>	<b>191</b>	<b>20 to 5000</b>
This is the lead time constant of the back emf feedback filter which is used for reducing armature voltage overshoots when accelerating fast through base speed with a default of 100 (ms). Refer to Chapter 5: "Control Loops" for details of Tuning.		
<b>BEMF FBK LAG</b>	<b>192</b>	<b>20 to 5000</b>
This is the lag time constant of the above feedback filter. If the filter is active, the ratio of lead / lag should always be greater than 1 to give an overall lead action which reduces the voltage overshoot and less than, typically, 3 for stable control. The default values cancel each other and make the filter inactive with a default of 100 (ms). Refer to Chapter 5: "Control Loops" for details of Tuning.		
<b>FLD. QUENCH DELAY</b>	<b>185</b>	<b>0.0 to 600.0 s</b>
If dynamic braking is used the field must be maintained for a period after the drive is disabled until the motor reaches zero speed. The field quench delay is the period of time that the field is maintained for when the drive is disabled.		
<b>FLD. QUENCH MODE</b>	<b>186</b>	<b>QUENCH / STANDBY</b>
After the field quench delay has expired, the field can be entirely quenched or put into a standby mode at 50% of rated current or volts depending whether in current or voltage control mode respectively. (The default standby value of 50% can be modified through the "SYSTEM / Reserved" Menu which is primarily for factory use only and requires the "super" password.)		
<b>FIELD I THRESH</b>	<b>617</b>	<b>0.00 to 100.00 %</b>
Threshold for UP TO FIELD diagnostic as a percentage of calibrated field current (see below).		
<b>FLD. CTRL MODE</b>	<b>209</b>	<b>See below</b>
Selects between open-loop VOLTAGE CONTROL or closed-loop CURRENT CONTROL.		
<b>FLD. VOLTS RATIO</b>	<b>210</b>	<b>0.0 to 100.0 %</b>
Sets the output dc field voltage as a percentage of the RMS FIELD supply voltage (line-to-line) when FLD CTRL MODE is set to VOLTAGE CONTROL.		
<b>FIELD ENABLED</b>	<b>169</b>	<b>DISABLED / ENABLED</b>
Refer to Chapter 6: "The Keypad" - The Keypad Menus (DIAGNOSTICS).		

<b>FIELD CONTROL</b>		
<b>Parameter</b>	<b>Tag</b>	<b>Range</b>
<b>FIELD DEMAND</b>	<b>183</b>	<b>—.xx %</b>
<i>Refer to Chapter 6: "The Keypad" - The Keypad Menus (DIAGNOSTICS).</i>		
<b>FLD. FIRING ANGLE</b>	<b>184</b>	<b>—.xx DEG</b>
<i>Refer to Chapter 6: "The Keypad" - The Keypad Menus (DIAGNOSTICS).</i>		
<b>FIELD I FBK.</b>	<b>300</b>	<b>—.xx %</b>
Field current feedback, as a percentage of the calibrated level.		
<b>FIELD I FBK.AMPS</b>	<b>539</b>	<b>—.x A</b>
FIELD I FBK calibrated in Amps.		
<b>UP TO FIELD</b>	<b>618</b>	<b>FALSE / TRUE</b>
Field current feedback is above FIELD I THRESHOLD when TRUE. This may be used as part of a mechanical brake release strategy.		
<b>WEAK PID ERROR</b>	<b>1185</b>	<b>—.xx %</b>
Input error, as a percentage of calibrated Volts, to the field weakening controller. This is formed from the spill-over of filtered BEMF above the MAX VOLTS setting.		
<b>WEAK PID OUT</b>	<b>1186</b>	<b>—.xx %</b>
Output field reduction demand, as a percentage of calibrated field current, from the field weakening controller.		
<b>FIELD STATE</b>	<b>1187</b>	<b>See below</b>
State of the field controller.		
0 : FIELD INIT		
1 : FIELD QUENCH		
2 : FIELD STANDBY		
3 : FIELD FULL FLD		
4 : FIELD TIMER            indicates that the FLD.QUENCH DELAY timer is counting down		
5 : FIELD ERROR		
6 : LOCAL BEMF		
<b>BEMF SOURCE</b>	<b>1273</b>	<b>LOCAL BEMF / BEMF INPUT</b>
Selects the source of the back-emf feedback into the field weakening control loop.		
Setting LOCAL BEMF makes use of the back-emf measured at the armature terminals.		
Setting BEMF INPUT uses the value in the parameter BEMF INPUT as the feedback for the field weakening control.		

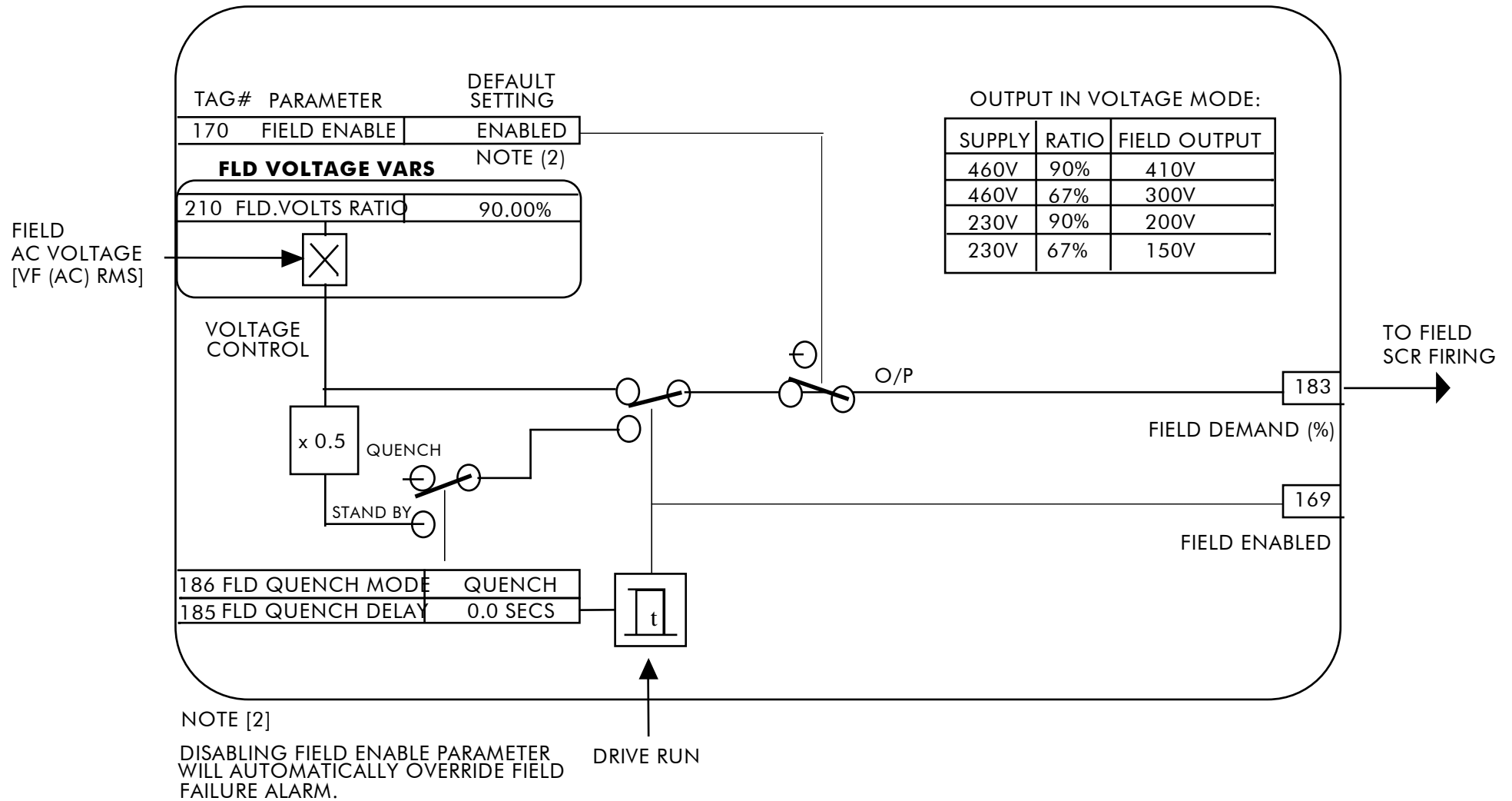
**FIELD CONTROL**

Parameter	Tag	Range
<b>BEMF INPUT</b>	<b>1274</b>	<b>—,xx %</b>
<p>The feedback value of back-emf used for the field weakening control, when BEMF SOURCE is set to BEMF INPUT. It allows for the use of the field weakening control structure on motors not directly connected to the armature terminals. It can be wired within the block diagram to an analogue input or a communications path.</p> <p>The use of this parameter is typically combined with parameters ISOL DMD SOURCE and 3-PHASE FIELD (CURRENT LOOP function block) to apply the drive to field weakening control of a motor field.</p> <p>Note: If the ADVANCED field weakening mode is being used with an external back-emf feedback, ensure to apply the speed feedback so that the base speed calculator can function correctly.</p>		

---

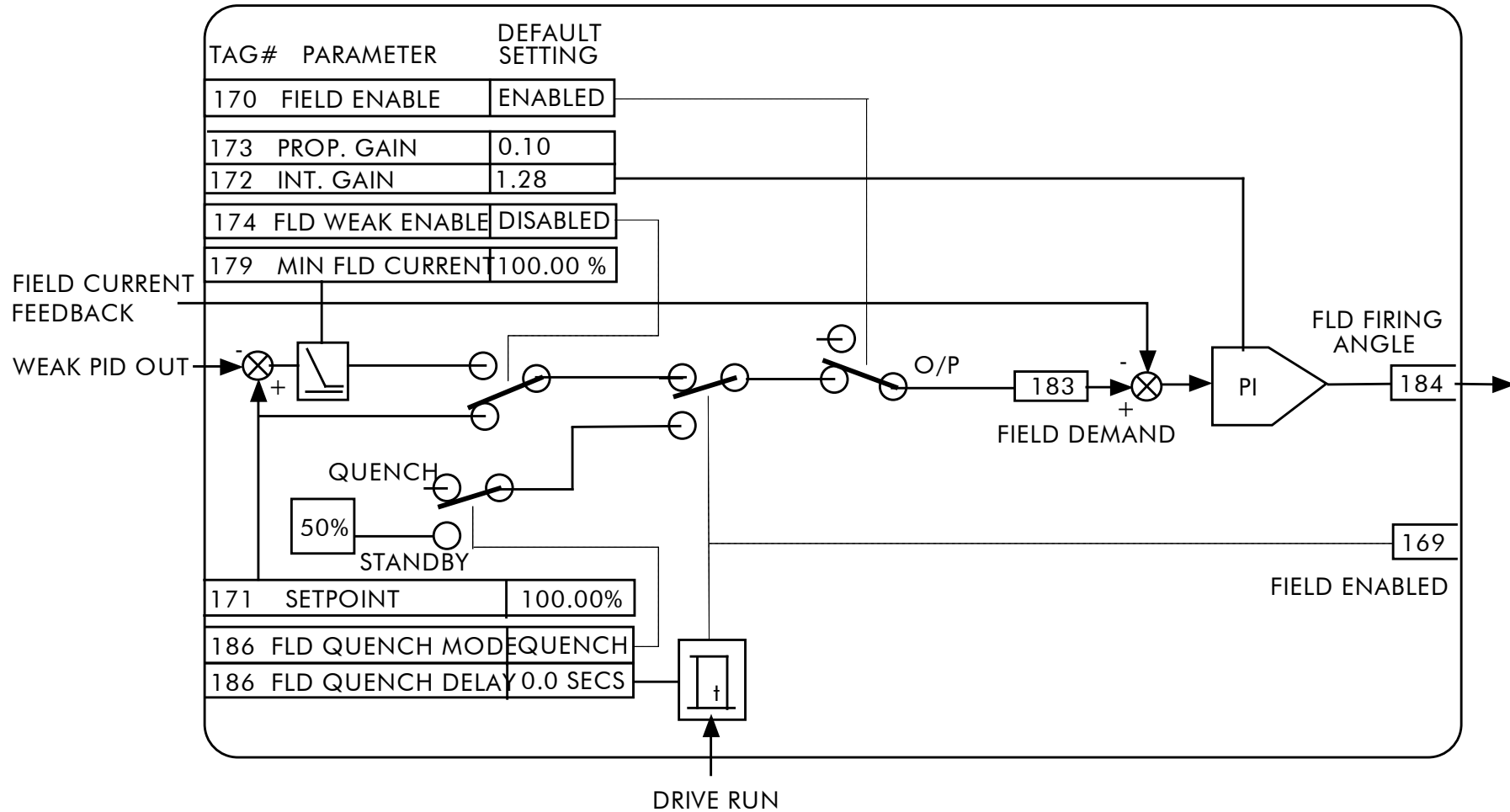
## Functional Description

### FIELD CONTROL MODE : VOLTAGE

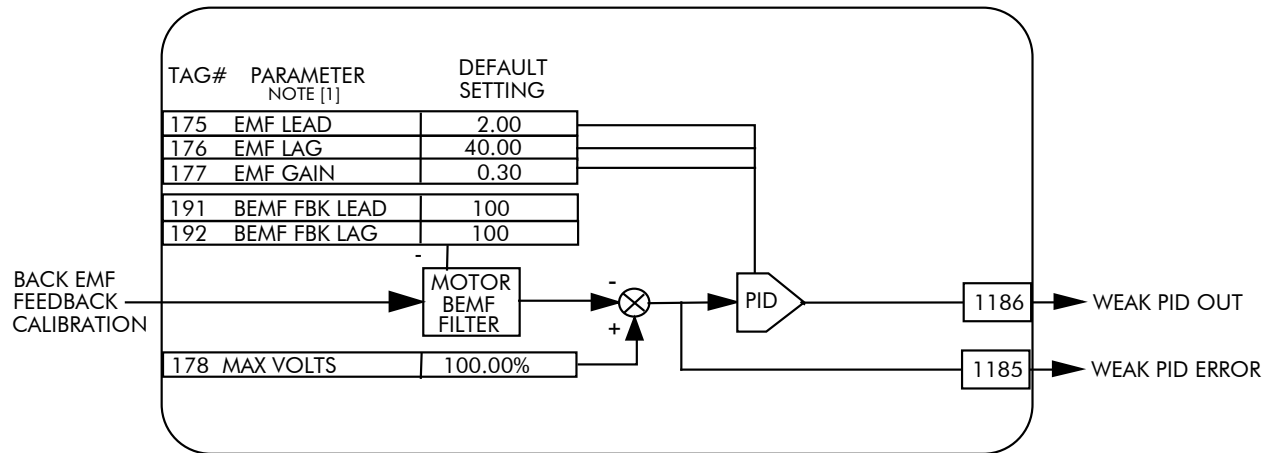




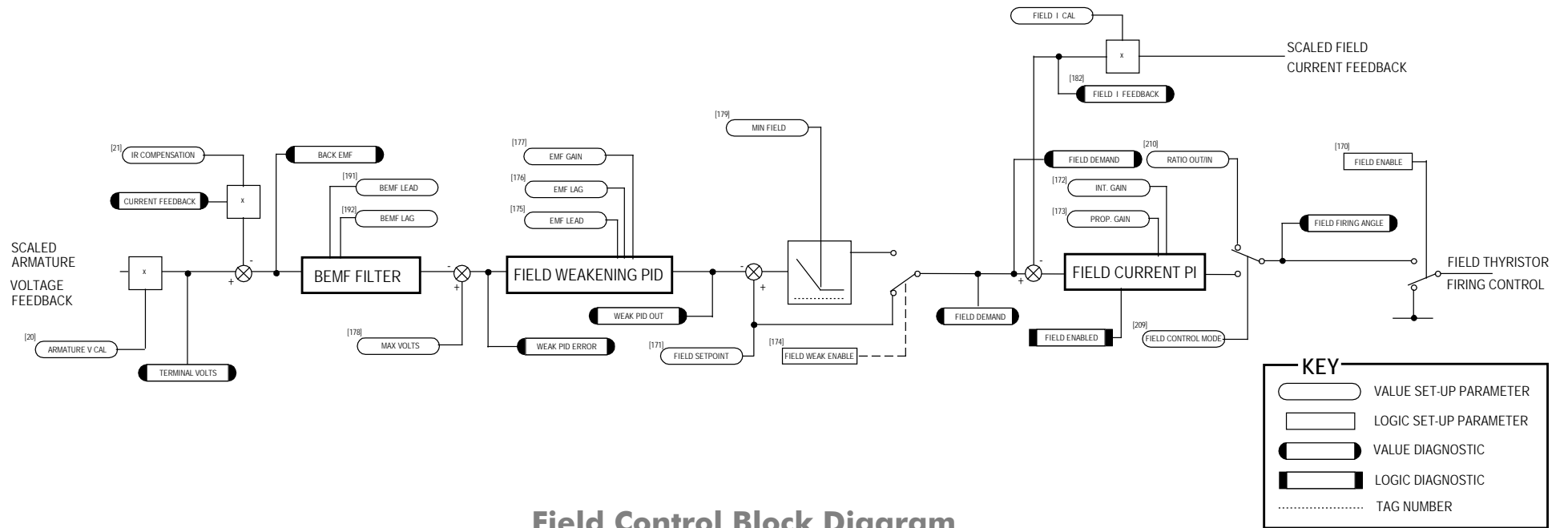
### FIELD CONTROL MODE : CURRENT



### FLD WEAK VARS



NOTE [1]  
FIELD WEAKENING OPERATION REQUIRES ENCODER OR ANALOG TACH FEEDBACK



**KEY**

- VALUE SET-UP PARAMETER
- LOGIC SET-UP PARAMETER
- VALUE DIAGNOSTIC
- LOGIC DIAGNOSTIC
- ..... TAG NUMBER

Field Control Block Diagram

**MMI Menu Map**

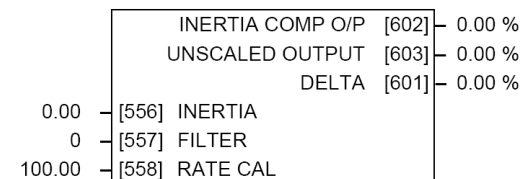
- 1 SETUP PARAMETERS
- 2 SPEED LOOP
- 3 ADVANCED
- 4 INERTIA COMP
  - INERTIA
  - FILTER
  - RATE CAL
  - DELTA
  - UNSCALED OUTPUT
  - INERTIA COMP O/P

# INERTIA COMP

**This function block directly compensates for load inertia during acceleration.**

This is particularly useful in high accuracy applications such as positioning systems and elevators. The block calculates its output at the same rate as the current loop for maximum performance.

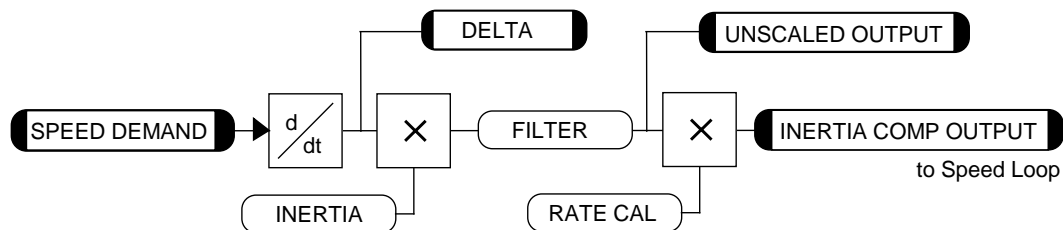
FUNCTION BLOCKS\MOTOR CONTROL\INERTIA COMP



## INERTIA COMP

Parameter	Tag	Range
<b>INERTIA</b>	<b>556</b>	<b>0.00 to 200.00</b>
The value of current necessary to accelerate load to 100% speed in 1 second.		
<b>FILTER</b>	<b>557</b>	<b>0 to 20000</b>
Low pass filter acting on the DELTA parameter.		
<b>RATE CAL</b>	<b>558</b>	<b>0.00 to 200.00</b>
Inertia compensation scaling factor.		
<b>INERTIA COMP O/P</b>	<b>602</b>	<b>— .xx %</b>
Inertia compensation directly added to the speed loop output.		
<b>UNSCALED OUTPUT</b>	<b>603</b>	<b>— .xx %</b>
Unscaled inertia compensation.		
<b>DELTA</b>	<b>601</b>	<b>— .xx %</b>
Rate of change of speed demand in %/s <sup>2</sup> .		

## Functional Description



**MMI Menu Map**

- 1 FUNCTION BLOCKS
- 2 MISCELLANEOUS
- 3 LINK
- 4 LINK 1
- 4 LINK 80
  - SOURCE TAG
  - DESTINATION TAG

## LINK

Use internal links to connect between function block parameters.

FUNCTION BLOCKS\MISCELLANEOUS\LINK\LINK1

- 0 - [364] SOURCE TAG
- 0 - [365] DESTINATION TAG

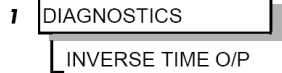
FUNCTION BLOCKS\MISCELLANEOUS\LINK\LINK80

- 0 - [778] SOURCE TAG
- 0 - [779] DESTINATION TAG

## LINK

Parameter	Tag	Range
<b>LINK 1 - 80</b>		
<b>SOURCE TAG</b>	<b>Refer to Parameter Table</b>	<b>-1276 to 1276</b>
Enter the tag number of the source input value. Refer to “Making and Breaking Function Block Connections”, page D-2.		
<b>DESTINATION TAG</b>	<b>Refer to Parameter Table</b>	<b>0 to 1276</b>
Enter the tag number for the destination output value. Refer to “Making and Breaking Function Block Connections”, page D-2.		

**MMI Menu Map**



## INVERSE TIME

**The purpose of the inverse time is to automatically reduce the current limit in response to prolonged overload conditions.**

FUNCTION BLOCKS/MOTOR CONTROL/INVERSE TIME

INVERSE TIME [203] 0.00 %

As the motor current exceeds an internal threshold of 103%, the excess current is integrated. The inverse time output remains unchanged until the integrated value is equivalent to an overload of 200% current for 60s. Once this limit is reached the integral value is clamped, and the inverse time output is decreased towards 103% at 10% per second.

Should the current drop below the 103% threshold the integrator value starts to discharge. As soon as the integrated value is less than the maximum overload level the inverse time output is allowed to ramp back up to 200% at a rate of 10% per second.

The inverse time output parameter is internally used by the current loop.

### INVERSE TIME

Parameter	Tag	Range
INVERSE TIME	203	—.xx %

Inverse time clamp output level.

**MMI Menu Map**

- 1 SETUP PARAMETERS
- 2 JOG/SLACK
  - JOG SPEED 1
  - JOG SPEED 2
  - TAKE UP 1
  - TAKE UP 2
  - CRAWL SPEED
  - MODE
  - RAMP RATE

**MMI Menu Map**

- 1 FUNCTION BLOCKS
- 2 SEQ & REF
- 3 JOG/SLACK
  - JOG/SLACK OUTPUT

# JOG/SLACK

This block can be used to provide jog, take up slack and crawl speed functions.

The inputs to this block are the Start and Jog signals via the SEQUENCING function block, and the speed demand from the RAMPS function block. The output of this block is connected to the RAMPS function block.

The JOG/SLACK parameters modify or replace the ramp input speed demand. You should use a spare digital input to switch between modes to achieve full functionality.

The JOG/SLACK OUTPUT parameter is internally connected to the RAMPS function block. This output is the modified value of the speed demand as required by MODE, Start, and Jog. These settings are shown in the Setpoint Selection table.

- **Jog:** With the Start signal OFF, the jog speed demand replaces the ramp input speed demand. MODE selects between jog setpoints 1 and 2. The jog RAMP RATE replaces the RAMP ACCEL TIME and RAMP DECEL TIME in the RAMPS function block. % S-RAMP is also set to 0.00%.
- **Take Up Slack:** With the Start signal ON, the jog signal performs a "take up slack" function. When a jog signal is received, the take up slack setpoint is added to the ramp input speed demand. MODE and Jog settings, from the table, select between the two take-up slack setpoints.
- **Crawl:** CRAWL SPEED replaces the ramp input speed demand as the output signal when both Start and Jog signals are ON, and MODE is TRUE.

FUNCTION BLOCKS/SEQ & REF/JOG/SLACK

5.00 %	- [218] JOG SPEED 1	OPERATING MODE [212]	STOP
-5.00 %	- [219] JOG SPEED 2	JOG/SLACK OUTPUT [698]	0.00 %
5.00 %	- [253] TAKE UP 1		
-5.00 %	- [254] TAKE UP 2		
10.00 %	- [225] CRAWL SPEED		
FALSE	- [228] MODE		
1.0 s	- [355] RAMP RATE		

## JOG/SLACK

Parameter	Tag	Range
<b>JOG SPEED 1</b> Jog speed setpoint 1.	<b>218</b>	<b>-100.00 to 100.00 %</b>
<b>JOG SPEED 2</b> Jog speed setpoint 2.	<b>219</b>	<b>-100.00 to 100.00 %</b>
<b>TAKE UP 1</b> Take-up slack speed setpoint 1.	<b>253</b>	<b>-100.00 to 100.00 %</b>
<b>TAKE UP 2</b> Take-up slack speed setpoint 2.	<b>254</b>	<b>-100.00 to 100.00 %</b>
<b>CRAWL SPEED</b> Crawl speed setpoint.	<b>225</b>	<b>-100.00 to 100.00 %</b>
<b>MODE</b> Selects jog speed setpoints, take up setpoints, and the crawl setpoint. To achieve full functionality, connect MODE to a spare digital input.	<b>228</b>	<b>FALSE / TRUE</b>

<b>JOG/SLACK</b>		
Parameter	Tag	Range
<b>RAMP RATE</b>	<b>355</b>	<b>0.1 to 600.0 s</b>
The ramp rate used while jogging. This is independent of the main ramp rate during normal running. The acceleration and deceleration times in jog are always equal.		
<b>OPERATING MODE</b>	<b>212</b>	<b>See below</b>
<i>Refer to Chapter 6: "The Keypad" - The Keypad Menus (DIAGNOSTICS).</i>		
0 : STOP		
1 : STOP		
2 : JOG SP. 1		
3 : JOG SP. 2		
4 : RUN		
5 : TAKE UP SP. 1		
6 : TAKE UP SP. 2		
7 : CRAWL		
<b>JOG/SLACK OUTPUT</b>	<b>698</b>	<b>____.00 %</b>
The setpoint combined with the JOG / SLACK function.		

## Functional Description

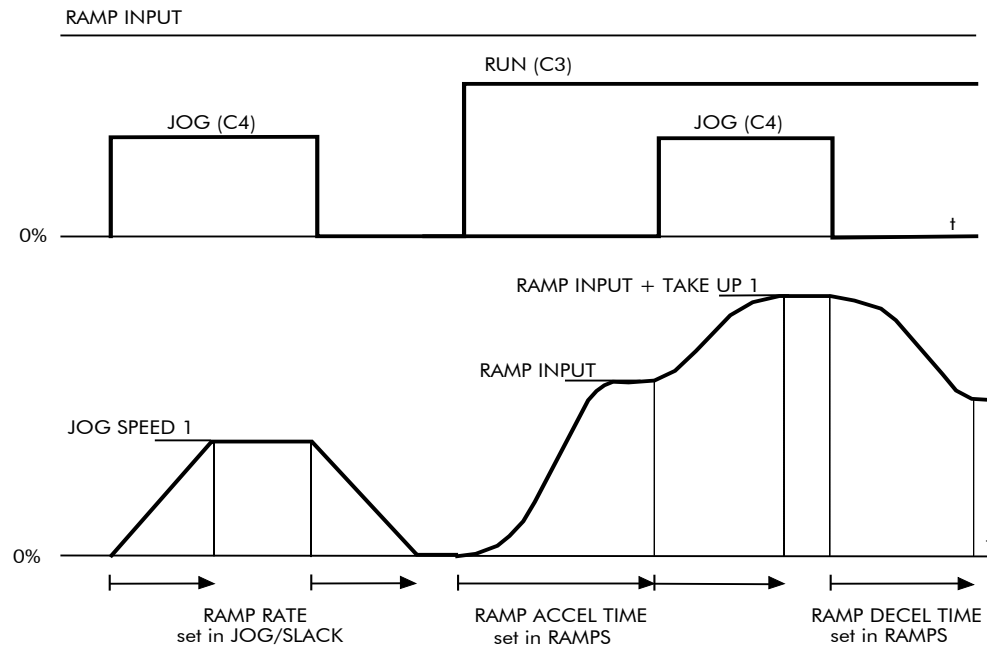
**NOTE**

The setpoint column in the table below refers to the Ramp Input ONLY, as indicated in the table. Any "direct" setpoints present will also add to this setpoint to make the total speed setpoint. If you don't want this to happen, for example during jogging, then disconnect the direct setpoint(s) during the appropriate conditions.

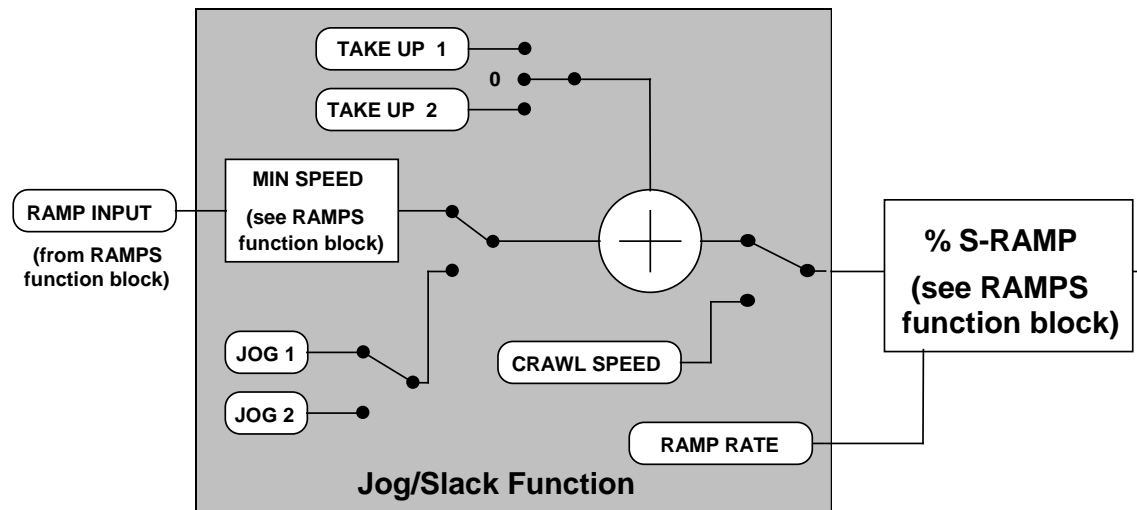
### Setpoint Selection Table

OPERATING MODE [212] - diagnostic	Start C3	Jog C4	MODE [228]	Ramp Input	Ramp Time	Contactor
0 : STOP	OFF	OFF	False	Setpoint	Default	OFF
1 : STOP	OFF	OFF	True	Setpoint	Default	OFF
2 : JOG SP. 1 (inch/jog 1)	OFF	ON	False	JOG SPEED 1	RAMP RATE	ON
3 : JOG SP. 2 (inch/jog 2)	OFF	ON	True	JOG SPEED 2	RAMP RATE	ON
4 : RUN	ON	OFF	False	Setpoint	Default	ON
5 : TAKE UP SP. 1 (take-up slack 1)	ON *	ON *	False	Setpoint + TAKE UP 1	Default	ON
6 : TAKE UP SP. 2 (take-up slack 2)	ON	OFF	True	Setpoint + TAKE UP 2	Default	ON
7 : CRAWL	ON *	ON *	True	CRAWL SPEED	Default	ON

\* Start (C3) and Jog (C4) must be applied (ON) simultaneously in the cases of TAKE UP SP.1 and CRAWL.



### Block Diagram





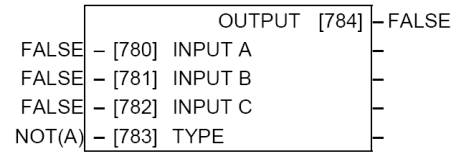
## LOGIC FUNC

These generic function blocks can be configured to perform one of a number of simple functions upon a fixed number of inputs.

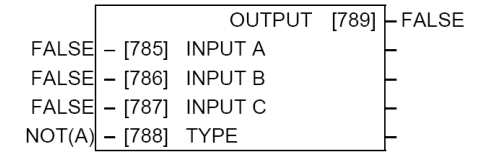
### MMI Menu Map

1	FUNCTION BLOCKS
2	MISCELLANEOUS
3	LOGIC FUNC
4	LOGIC FUNC 1
4	LOGIC FUNC 2
4	LOGIC FUNC 3
4	LOGIC FUNC 4
4	LOGIC FUNC 5
4	LOGIC FUNC 6
4	LOGIC FUNC 7
4	LOGIC FUNC 8
4	LOGIC FUNC 9
4	LOGIC FUNC 10
	INPUT A
	INPUT B
	INPUT C
	TYPE
	OUTPUT

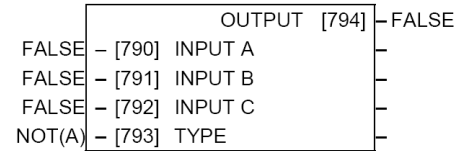
FUNCTION BLOCKS\MISCELLANEOUS\LOGIC FUNC\LOGIC FUNC 1



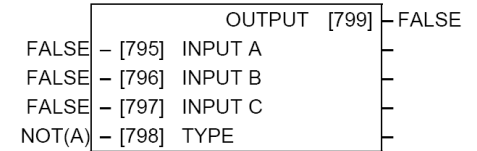
FUNCTION BLOCKS\MISCELLANEOUS\LOGIC FUNC\LOGIC FUNC 2



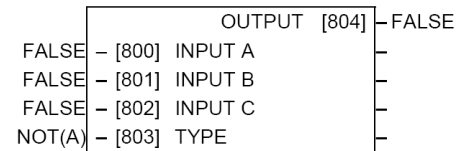
FUNCTION BLOCKS\MISCELLANEOUS\LOGIC FUNC\LOGIC FUNC 3



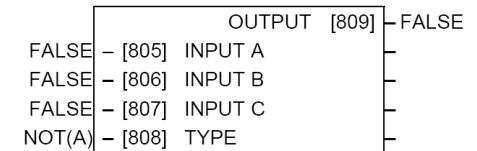
FUNCTION BLOCKS\MISCELLANEOUS\LOGIC FUNC\LOGIC FUNC 4



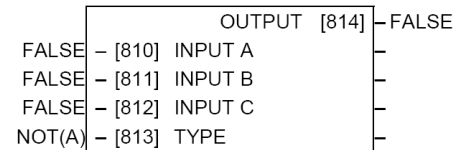
FUNCTION BLOCKS\MISCELLANEOUS\LOGIC FUNC\LOGIC FUNC 5



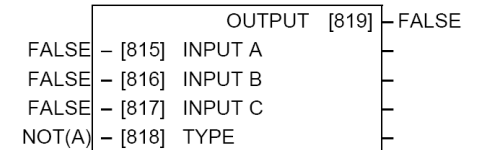
FUNCTION BLOCKS\MISCELLANEOUS\LOGIC FUNC\LOGIC FUNC 6



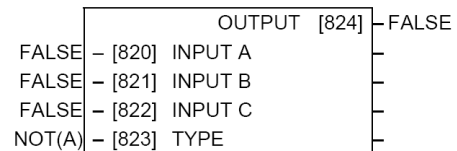
FUNCTION BLOCKS\MISCELLANEOUS\LOGIC FUNC\LOGIC FUNC 7



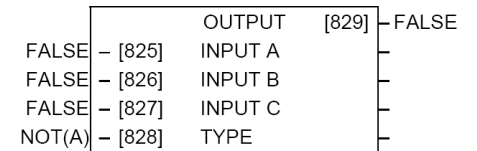
FUNCTION BLOCKS\MISCELLANEOUS\LOGIC FUNC\LOGIC FUNC 8



FUNCTION BLOCKS\MISCELLANEOUS\LOGIC FUNC\LOGIC FUNC 9

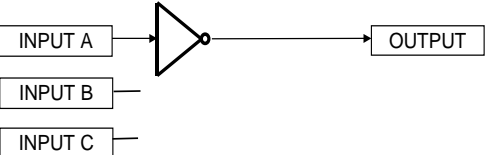
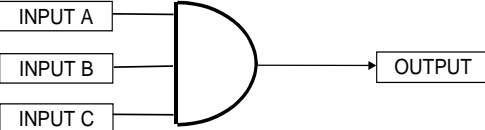
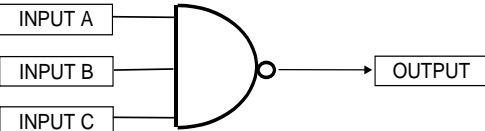
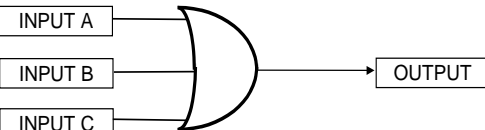
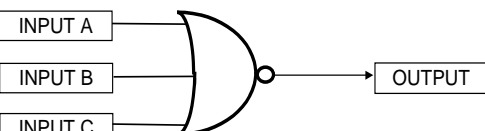
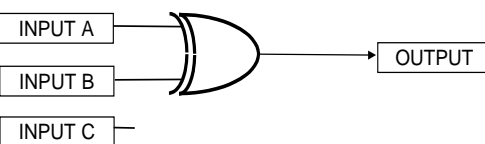


FUNCTION BLOCKS\MISCELLANEOUS\LOGIC FUNC\LOGIC FUNC 10



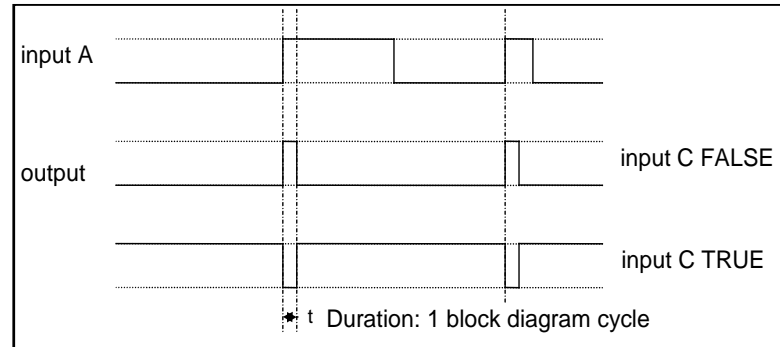
<b>LOGIC FUNC</b>		
<b>Parameter</b>	<b>Tag</b>	<b>Range</b>
<b>INPUT A</b>	<b>780, 785, 790, 795, 800, 805, 810, 815, 820, 825</b>	<b>FALSE / TRUE</b>
General purpose logic input.		
<b>INPUT B</b>	<b>781, 786, 791, 796, 801, 806, 811, 816, 821, 826</b>	<b>FALSE / TRUE</b>
General purpose logic input.		
<b>INPUT C</b>	<b>782, 787, 792, 797, 802, 807, 812, 817, 822, 827</b>	<b>FALSE / TRUE</b>
General purpose logic input.		
<b>TYPE</b>	<b>783, 788, 793, 798, 803, 808, 813, 818, 823, 828</b>	<b>See below</b>
The operation to be performed on the three inputs to produce the output value. The operations that can be selected are:		
0: NOT(A)		
1: AND(A,B,C)		
2: NAND(A,B,C)		
3: OR(A,B,C)		
4: NOR(A,B,C)		
5: XOR(A,B)		
6: 0-1 EDGE(A)		
7: 1-0 EDGE(A)		
8: AND(A,B,!C)		
9: OR(A,B,!C)		
10: S FLIP-FLOP		
11: R FLIP-FLOP		
12: LATCH		
13: SWITCH		
14: (A AND B) OR C		
15: (A OR B) AND C		
<b>OUTPUT</b>	<b>784, 789, 794, 799, 804, 809, 814, 819, 824, 829</b>	<b>FALSE / TRUE</b>
The result of performing the selected operation on the inputs.		

## Functional Description

Operation	Description
NOT(A)	<p><b>NOT(A)</b></p> <p>If INPUT A is TRUE the OUTPUT is FALSE, otherwise the OUTPUT is TRUE.</p> 
AND(A,B,C)	<p><b>AND(A,B,C)</b></p> <p>If A and B and C are all TRUE then the OUTPUT is TRUE, otherwise the OUTPUT is FALSE.</p> 
NAND(A,B,C)	<p><b>NAND(A,B,C)</b></p> <p>If A and B and C are all TRUE then the OUTPUT is FALSE, otherwise the OUTPUT is TRUE.</p> 
OR(A,B,C)	<p><b>OR(A,B,C)</b></p> <p>If at least one of A or B or C is TRUE then the OUTPUT is TRUE, otherwise the OUTPUT is FALSE.</p> 
NOR(A,B,C)	<p><b>NOR(A,B,C)</b></p> <p>If at least one of A or B or C is TRUE then the OUTPUT is FALSE, otherwise the OUTPUT is TRUE.</p> 
XOR(A,B)	<p><b>XOR(A,B)</b></p> <p>If A and B are the same, (both TRUE or both FALSE), then the output is FALSE, otherwise the output is TRUE.</p> 

Operation	Description
-----------	-------------

0-1 EDGE(A)



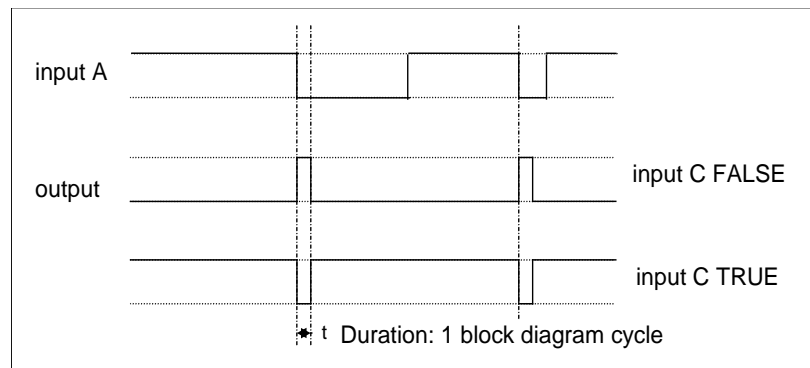
**Rising Edge Trigger**

Input B is not used.

This function outputs a pulse of 5ms duration when INPUT A to the block becomes TRUE. When INPUT C is TRUE, the output is inverted.

The output is held TRUE for one execution of the function block diagram.

1-0 EDGE(A)

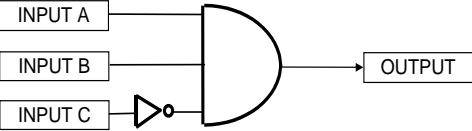
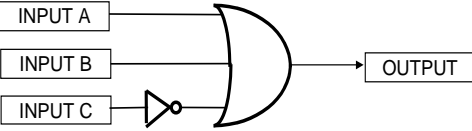
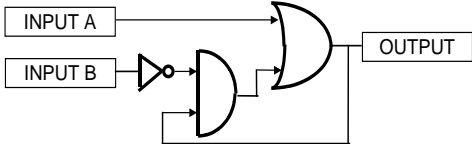


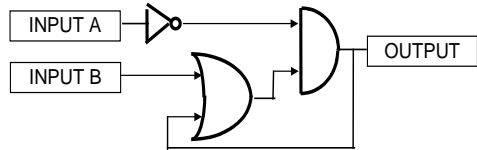
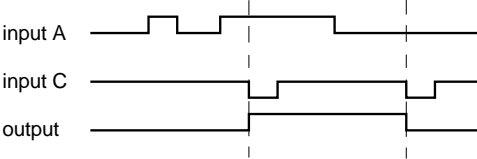
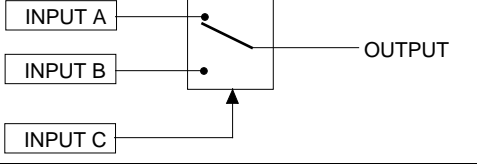
**Falling Edge Trigger**

Input B is not used.

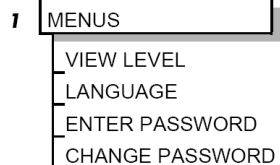
This function outputs a pulse of 20ms duration when INPUT A to the block becomes FALSE. When INPUT C is TRUE, the output is inverted.

The output is held TRUE for one execution of the function block diagram.

Operation	Description																																					
AND(A,B,!C)	<p><b>AND(A,B,!C)</b></p>  <p>Refer to the Truth Table. FALSE = 0, TRUE = 1.</p>	<p><b>Input State</b></p> <table border="1"> <thead> <tr> <th>A</th> <th>B</th> <th>C</th> <th>Output State</th> </tr> </thead> <tbody> <tr><td>0</td><td>0</td><td>0</td><td>0</td></tr> <tr><td>0</td><td>0</td><td>1</td><td>0</td></tr> <tr><td>0</td><td>1</td><td>0</td><td>0</td></tr> <tr><td>0</td><td>1</td><td>1</td><td>0</td></tr> <tr><td>1</td><td>0</td><td>0</td><td>0</td></tr> <tr><td>1</td><td>0</td><td>1</td><td>0</td></tr> <tr><td>1</td><td>1</td><td>0</td><td>1</td></tr> <tr><td>1</td><td>1</td><td>1</td><td>0</td></tr> </tbody> </table>	A	B	C	Output State	0	0	0	0	0	0	1	0	0	1	0	0	0	1	1	0	1	0	0	0	1	0	1	0	1	1	0	1	1	1	1	0
A	B	C	Output State																																			
0	0	0	0																																			
0	0	1	0																																			
0	1	0	0																																			
0	1	1	0																																			
1	0	0	0																																			
1	0	1	0																																			
1	1	0	1																																			
1	1	1	0																																			
OR(A,B,!C)	<p><b>OR(A,B,!C)</b></p>  <p>Refer to the Truth Table. FALSE = 0, TRUE = 1.</p>	<p><b>Input State</b></p> <table border="1"> <thead> <tr> <th>A</th> <th>B</th> <th>C</th> <th>Output State</th> </tr> </thead> <tbody> <tr><td>0</td><td>0</td><td>0</td><td>1</td></tr> <tr><td>0</td><td>0</td><td>1</td><td>0</td></tr> <tr><td>0</td><td>1</td><td>0</td><td>1</td></tr> <tr><td>0</td><td>1</td><td>1</td><td>1</td></tr> <tr><td>1</td><td>0</td><td>0</td><td>1</td></tr> <tr><td>1</td><td>0</td><td>1</td><td>1</td></tr> <tr><td>1</td><td>1</td><td>0</td><td>1</td></tr> <tr><td>1</td><td>1</td><td>1</td><td>1</td></tr> </tbody> </table>	A	B	C	Output State	0	0	0	1	0	0	1	0	0	1	0	1	0	1	1	1	1	0	0	1	1	0	1	1	1	1	0	1	1	1	1	1
A	B	C	Output State																																			
0	0	0	1																																			
0	0	1	0																																			
0	1	0	1																																			
0	1	1	1																																			
1	0	0	1																																			
1	0	1	1																																			
1	1	0	1																																			
1	1	1	1																																			
S FLIP-FLOP	<p><b>S FLIP-FLOP</b></p> 	<p>This is a set dominant flip-flop. INPUT A functions as <i>set</i>, and INPUT B as <i>reset</i> .</p>																																				

Operation	Description
R FLIP-FLOP	<p data-bbox="640 217 761 240"><b>R FLIP-FLOP</b></p> <p data-bbox="1128 217 2033 240">This is a reset dominant flip-flop. INPUT A functions as <i>reset</i>, and INPUT B as <i>set</i>.</p> 
LATCH	<p data-bbox="1128 413 2033 469">When INPUT C is low, the output is the value of INPUT A. This output value is then latched until INPUT C is low again. INPUT B is not used.</p> 
SWITCH	<p data-bbox="1128 595 2033 651">When INPUT C is FALSE, the output is equal to INPUT A. When INPUT C is TRUE, the output is equal to INPUT B.</p> 

**MMI Menu Map**



## MENUS

Use this block to select one of three MMI menu structures, to set a display language, and to protect the Keypad with a password.

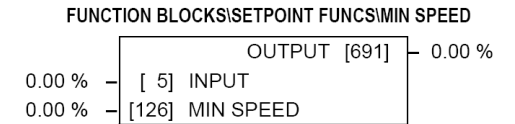
	FUNCTION BLOCKS	MENUS	MENUS
STANDARD	-	[ 37]	VIEW LEVEL
ENGLISH	-	[304]	LANGUAGE
0x0000	-	[120]	ENTER PASSWORD
0x0000	-	[121]	CHANGE PASSWORD

## MENUS

Parameter	Tag	Range
<b>VIEW LEVEL</b>	<b>37</b>	<b>BASIC / STANDARD / ADVANCED</b>
This parameter controls which parameters and menus are visible on the MMI. Refer to Chapter 6: "The Keypad" -The Menu System Map to see the effects of these selections.		
<b>LANGUAGE</b>	<b>304</b>	<b>ENGLISH / OTHER</b>
Selects the MMI display language. Other languages are available, please contact Parker SSD Drives. Refer also to Chapter 6: "The Keypad" - Selecting the Display Language.		
<b>ENTER PASSWORD</b>	<b>120</b>	<b>0x0000 to 0xFFFF</b>
Refer to Chapter 6: "The Keypad" - Password Protection for further instruction.		
<b>CHANGE PASSWORD</b>	<b>121</b>	<b>0x0000 to 0xFFFF</b>
Refer to Chapter 6: "The Keypad" - Password Protection for further instruction.		

# MIN SPEED

The Min Speed function block may be used to prevent the drive running with a zero setpoint.



- MMI Menu Map**
- 1 FUNCTION BLOCKS
  - 2 SETPOINT FUNCTIONS
  - 3 MIN SPEED
  - OUTPUT

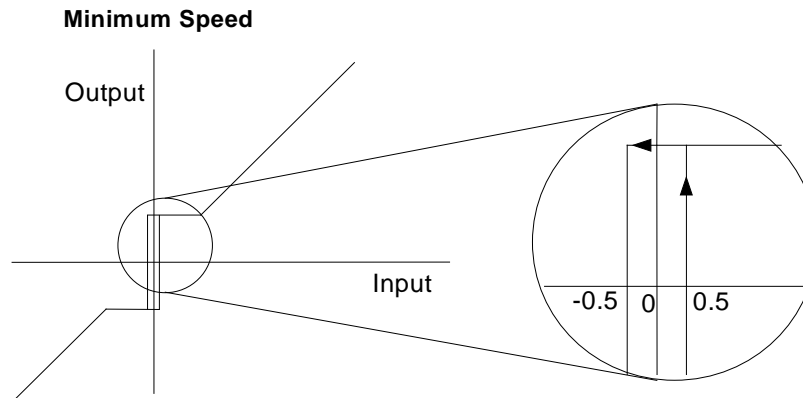
- MMI Menu Map**
- 1 SETUP PARAMETERS
  - 2 RAMPS
  - INPUT
  - MIN SPEED

## MIN SPEED

Parameter	Tag	Range
-----------	-----	-------

<b>INPUT</b>	<b>5</b>	<b>-105.00 to 105.00 %</b>
Input value.		

<b>MIN SPEED</b>	<b>126</b>	<b>0.00 to 100.00 %</b>
The minimum speed clamp is fully bi-directional and operates with a 0.5% hysteresis. If this parameter is less than 0.5% it is ignored and OUTPUT = INPUT.		



<b>OUTPUT</b>	<b>691</b>	<b>— .XX %</b>
Clamped value of input.		



**MMI Menu Map**

- 1 SYSTEM
- 2 miniLINK
  - VALUE 1
  - VALUE 2
  - VALUE 3
  - VALUE 4
  - VALUE 5
  - VALUE 6
  - VALUE 7
  - VALUE 8
  - VALUE 9
  - VALUE 10
  - VALUE 11
  - VALUE 12
  - VALUE 13
  - VALUE 14
  - LOGIC 1
  - LOGIC 2
  - LOGIC 3
  - LOGIC 4
  - LOGIC 5
  - LOGIC 6
  - LOGIC 7
  - LOGIC 8

## miniLINK

**These parameters are general purpose tags.**

These parameters are used extensively in conjunction with communications masters in order to map the field bus parameters into the drive. Refer to the appropriate Tech Box manual.

FUNCTION BLOCKS\COMMUNICATIONS\miniLINK

0.00 %	-	[339]	VALUE 1
0.00 %	-	[340]	VALUE 2
0.00 %	-	[341]	VALUE 3
0.00 %	-	[342]	VALUE 4
0.00 %	-	[343]	VALUE 5
0.00 %	-	[344]	VALUE 6
0.00 %	-	[345]	VALUE 7
0.00 %	-	[379]	VALUE 8
0.00 %	-	[380]	VALUE 9
0.00 %	-	[381]	VALUE 10
0.00 %	-	[382]	VALUE 11
0.00 %	-	[383]	VALUE 12
0.00 %	-	[384]	VALUE 13
0.00 %	-	[385]	VALUE 14
OFF	-	[346]	LOGIC 1
OFF	-	[347]	LOGIC 2
OFF	-	[348]	LOGIC 3
OFF	-	[349]	LOGIC 4
OFF	-	[350]	LOGIC 5
OFF	-	[351]	LOGIC 6
OFF	-	[352]	LOGIC 7
OFF	-	[353]	LOGIC 8

miniLINK		
Parameter	Tag	Range
<b>VALUE 1 to VALUE 14</b> General purpose inputs.	<b>339 to 385</b>	<b>-300.00 to 300.00 %</b>
<b>LOGIC 1 to LOGIC 8</b> General purpose logic inputs.	<b>346 to 353</b>	<b>OFF / ON</b>

**MMI Menu Map**

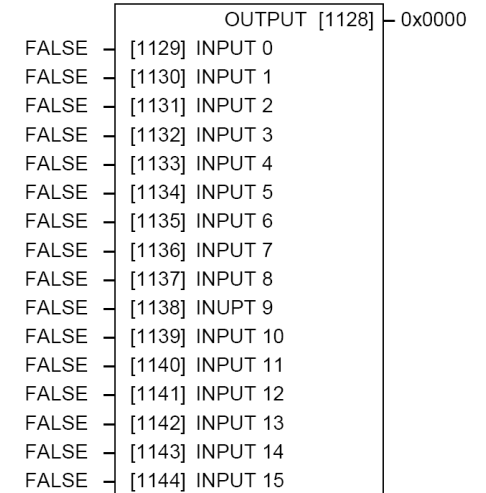
- 1 **FUNCTION BLOCKS**
- 2 **MISCELLANEOUS**
- 3 **MULTIPLEXER**
  - INPUT 0
  - INPUT 1
  - INPUT 2
  - INPUT 3
  - INPUT 4
  - INPUT 5
  - INPUT 6
  - INPUT 7
  - INPUT 8
  - INPUT 9
  - INPUT 10
  - INPUT 11
  - INPUT 12
  - INPUT 13
  - INPUT 14
  - INPUT 15
  - OUTPUT

## MULTIPLEXER

Each block collects together 16 Boolean input values into a single word.

For example, one may be used to collect individual bits within a word for efficient access from a communications master.

FUNCTION BLOCKS MISCELLANEOUS MULTIPLEXER



### MULTIPLEXER

Parameter	Tag	Range
<b>INPUT 0 to INPUT 15</b>	<b>1129 to 1144</b>	<b>FALSE / TRUE</b>
The Boolean inputs to be assembled into a single word.		
<b>OUTPUT</b>	<b>1128</b>	<b>0x0000 to 0xFFFF</b>
The resulting word.		

## OP STATION

MMI Set-up options and Local setpoint information.

### MMI Menu Map

- 1 SETUP PARAMETERS
- 2 OP-STATION
- 3 SET UP
  - SETPOINT
  - JOG SETPOINT
  - LOCAL KEY ENABLE

### MMI Menu Map

- 1 SETUP PARAMETERS
- 2 OP-STATION
- 3 START UP VALUES
  - INITIAL SETPOINT
  - INITIAL JOG
  - INITIAL DIRECTION
  - INITIAL VIEW
  - INITIAL MODE

### MMI Menu Map

- 1 SETUP PARAMETERS
- 2 OP-STATION
- 3 LOCAL RAMP
  - RAMP ACCEL TIME
  - RAMP DECEL TIME

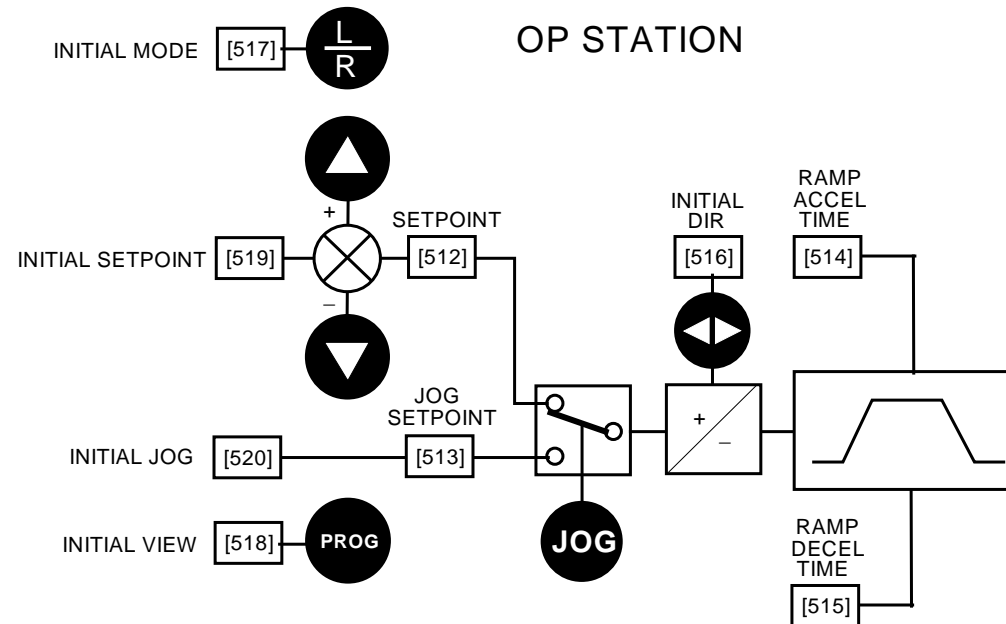
FUNCTION BLOCKS\MENUS\OP-STATION	
TRUE	[511] LOCAL KEY ENABLE
0.00 %	[512] SETPOINT
5.00 %	[513] JOG SETPOINT
10.0 s	[514] RAMP ACCEL TIME
10.0 s	[515] RAMP DECEL TIME
FORWARD	[516] INITIAL DIR
REMOTE	[517] INITIAL MODE
LOCAL	[518] INITIAL VIEW
0.00 %	[519] INITIAL SETPOINT
5.00 %	[520] INITIAL JOG

## OP STATION

Parameter	Tag	Range
<b>LOCAL KEY ENABLE</b>	<b>511</b>	<b>FALSE / TRUE</b>
Enables the LOCAL/REMOTE control key on the op-station. Set to TRUE to allow the operator to toggle between local and remote modes.		
<b>SETPOINT</b>	<b>512</b>	<b>0.00 to 100.00 %</b>
SET UP menu - Actual value of local setpoint. This value is not persistent.		
<b>JOG SETPOINT</b>	<b>513</b>	<b>0.00 to 100.00 %</b>
SET UP menu - Actual value of local jog setpoint. This value is not persistent.		
<b>RAMP ACCEL TIME</b>	<b>514</b>	<b>0.1 to 600.0 s</b>
Acceleration time used while in Local mode.		
<b>RAMP DECEL TIME</b>	<b>515</b>	<b>0.1 to 600.0 s</b>
Deceleration time used while in Local mode.		
<b>INITIAL DIR</b>	<b>516</b>	<b>REVERSE / FORWARD</b>
START UP VALUES menu - Start-up mode of local direction on power-up. Set to TRUE for Forward.		
<b>INITIAL MODE</b>	<b>517</b>	<b>REMOTE / LOCAL</b>
START UP VALUES menu - Start-up mode of Keypad LOCAL/REMOTE control key on power-up. Set to TRUE for Local mode.		
<b>INITIAL VIEW</b>	<b>518</b>	<b>LOCAL / PROGRAM</b>
START UP VALUES menu - Start-up mode of Keypad PROG key on power-up. Set to TRUE for Program mode to see the local setpoint.		

OP STATION		
Parameter	Tag	Range
<b>INITIAL SETPOINT</b>	<b>519</b>	<b>0.00 to 100.00 %</b>
START UP VALUES menu - Default value of local setpoint on power-up.		
<b>INITIAL JOG</b>	<b>520</b>	<b>0.00 to 100.00 %</b>
START UP VALUES menu - Default Value of local jog setpoint on power up.		

### Functional Description



*Local Setpoint (only active when the drive is in Local mode)*

## PID

### MMI Menu Map

- 1 SETUP PARAMETERS
- 2 SPECIAL BLOCKS
- 3 PID
  - PROP. GAIN
  - INT.TIME.CONST
  - DERIVATIVE TC
  - POSITIVE LIMIT
  - NEGATIVE LIMIT
  - O/P SCALER(TRIM)
  - INPUT 1
  - INPUT 2
  - RATIO 1
  - RATIO 2
  - DIVIDER 1
  - DIVIDER 2
  - ENABLE
  - INT. DEFEAT
  - FILTER T.C.

This is a general purpose PID block which can be used for many different closed loop control applications.

The PID feedback can be loadcell tension, dancer position or any other transducer feedback such as pressure, flow etc.

This block is ignored by the drive unless SYSTEM::CONFIGURE I/O::BLOCK DIAGRAM::PID O/P DEST is connected to a non-zero tag.

#### Features:

- Independent adjustment of gain and time constants.
- Additional first-order filter (F).
- Functions P, PI, PD, PID with/without F individually selected.
- Ratio and divider for scaling each input.
- Independent positive and negative limits.
- Output scaler (Trim).
- Gain profiled by diameter for centre-driven winder control.

### MMI Menu Map

- 1 DIAGNOSTICS
  - PID OUTPUT
  - PID CLAMPED
  - PID ERROR

### MMI Menu Map

- 1 FUNCTION BLOCKS
  - HI RES PROP GAIN

### FUNCTION BLOCKS\SETPOINT FUNCS\PID

	PID OUTPUT	[417]	0.00 %
	PID CLAMPED	[416]	FALSE
	PID ERROR	[415]	0.00 %
1.0	[711] PROP. GAIN		
5.00 s	[402] INT. TIME CONST.		
0.000 s	[401] DERIVATIVE TC		
0.100 s	[403] FILTER T.C.		
100.00 %	[405] POSITIVE LIMIT		
-100.00 %	[406] NEGATIVE LIMIT		
0.2000	[407] O/P SCALER (TRIM)		
0.00 %	[410] INPUT 1		
0.00 %	[411] INPUT 2		
1.0000	[412] RATIO 1		
1.0000	[413] RATIO 2		
1.0000	[418] DIVIDER 1		
1.0000	[414] DIVIDER 2		
ENABLED	[408] ENABLE		
OFF	[409] INT. DEFEAT		
0.000	[1259] HI RES PROP GAIN		

## PID

Parameter	Tag	Range
<b>PROP. GAIN</b>	<b>711</b>	<b>0.0 to 100.0</b>
The maximum limit of the proportional gain. This is a pure gain factor which shifts up or down the whole Bode PID transfer function leaving the time constants unaffected. A value of P = 10.0 means that, for an error of 5%, the proportional part (initial step) of the PID output will be: $10 \times [1 + (T_d/T_i)] \times 5\%$ , i.e. approx. 50% for $T_d \ll T_i$ . Also refer to HI RES PROP GAIN below.		
<b>INT. TIME CONST.</b>	<b>402</b>	<b>0.01 to 100.00 s</b>
The integral time constant ( $T_i$ )		
<b>DERIVATIVE TC</b>	<b>401</b>	<b>0.000 to 10.000 s</b>
The derivative time constant ( $T_d$ ). Set this value to 0.000 to remove the derivative term.		
<b>FILTER T.C.</b>	<b>403</b>	<b>0.000 to 10.000 s</b>
A first-order filter for removing high frequency noise from the PID output. When set to 0.000 the filter is removed. The high frequency lift of the transfer function is determined by the ratio k of the Derivative Time Const ( $T_d$ ) over the Filter Time Constant ( $T_f$ ) - typically 4 of 5.		

<b>PID</b>		
<b>Parameter</b>	<b>Tag</b>	<b>Range</b>
<b>POSITIVE LIMIT</b> The upper limit of the PID algorithm.	<b>405</b>	<b>0.00 to 105.00 %</b>
<b>NEGATIVE LIMIT</b> The lower limit of the PID algorithm.	<b>406</b>	<b>-105.00 to 0.00 %</b>
<b>O/P SCALER (TRIM)</b> The ratio that the limited PID output is multiplied by in order to give the final PID Output. Normally this ratio would be between 0 and 1.	<b>407</b>	<b>-3.0000 to 3.0000</b>
<b>INPUT 1</b> PID setpoint input. This can be either a position/tension feedback or a reference/offset.	<b>410</b>	<b>-300.00 to 300.00 %</b>
<b>INPUT 2</b> PID feedback input. This can be either a position/tension feedback or a reference/offset	<b>411</b>	<b>-300.00 to 300.00 %</b>
<b>RATIO 1</b> This multiplies Input 1 by a factor (Ratio 1).	<b>412</b>	<b>-3.0000 to 3.0000</b>
<b>RATIO 2</b> This multiplies Input 2 by a factor (Ratio 2).	<b>413</b>	<b>-3.0000 to 3.0000</b>
<b>DIVIDER 1</b> This divides Input 1 by a factor (Divider 1).	<b>418</b>	<b>-3.0000 to 3.0000</b>
<b>DIVIDER 2</b> This divides Input 2 by a factor (Divider 2).	<b>414</b>	<b>-3.0000 to 3.0000</b>
<b>ENABLE</b> Enables or disables the PID output.	<b>408</b>	<b>DISABLED / ENABLED</b>
<b>INT. DEFEAT</b> When ON, the Integral term is disabled. The block transfer function then becomes P+D only.	<b>409</b>	<b>OFF / ON</b>
<b>HI RES PROP GAIN</b> Additive, high resolution, proportional term gain. This value is added to PROP GAIN to form the total proportional term gain. Its default value is 0.000 (unused).	<b>1259</b>	<b>0.000 to 100.000</b>
<b>PID OUTPUT</b> <i>Refer to Chapter 6: "The Keypad" - The Keypad Menus (DIAGNOSTICS).</i>	<b>417</b>	<b>— .xx %</b>
<b>PID CLAMPED</b> <i>Refer to Chapter 6: "The Keypad" - The Keypad Menus (DIAGNOSTICS).</i>	<b>416</b>	<b>FALSE / TRUE</b>
<b>PID ERROR</b> <i>Refer to Chapter 6: "The Keypad" - The Keypad Menus (DIAGNOSTICS).</i>	<b>415</b>	<b>— .xx %</b>

## Functional Description

The following block diagram shows the internal structure of the PID block.

PID is used to control the response of any closed loop system. It is used specifically in system applications involving the control of drives to allow zero steady state error between Reference and Feedback, together with good transient performance.

The block executes a Proportional Gain + Integral + Derivative control algorithm, with an added filter to attenuate high-frequency noise. You can select P, PD, PI or PID as required.

### Proportional Gain (PROP. GAIN)

This is used to adjust the basic response of the closed loop control system. It is defined as the portion of the loop gain fed back to make the complete control loop stable. The PID error is multiplied by the Proportional Gain to produce an output.

### Integral (INT. TIME CONST.)

The Integral term is used to give zero steady state error between the setpoint and feedback values of the PID. If the integral is set to a small value, this will cause an underdamped or unstable control system.

### Derivative (DERIVATIVE TC)

This is used to correct for certain types of control loop instability, and therefore improve response. It is sometimes used when heavy or large inertia rolls are being controlled. The derivative term has an associated filter to suppress high frequency signals.

The algorithm modifies the error between the setpoint and the feedback with the proportional, integral, and derivative terms. The error is clamped internally to  $\pm 105\%$  maximum.

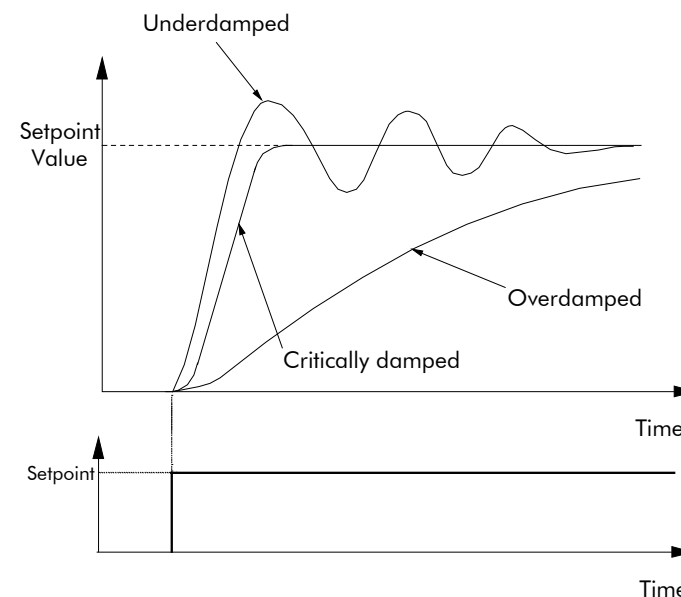
The proportional, integral, and derivative terms are scaled by PROP. GAIN, INT. TIME CONST., and DERIVATIVE TC respectively. An additional gain profiler can modify the proportional gain as the roll diameter changes. The block diagram shows how the proportional gain changes when using the profiler.

## Proportional Gain

Proportional gain scales the output based upon the input error. Increasing PROP. GAIN will improve the response time while increasing overshoot. MODE selects the proportional gain profile. When set to 0, the proportional gain remains constant over the entire roll. Changing the value of MODE increases the profile as shown opposite.

You should try to achieve a critically damped response which allows the mechanics to track as precisely as possible a step change on the setpoint.

## Critically Damped Response



## Integral Gain

Integral eliminates steady-state error. Reducing INT. TIME CONST. improves the response, however, if it is set too short it will cause instability. The integral value is clamped internally by the settings of POSITIVE LIMIT and NEGATIVE LIMIT. It is also held at the last value when the PID CLAMPED output is TRUE. Setting INT. DEFEAT to ON will disable the integral gain term.

## Derivative Gain

Derivative gain instantaneously boosts the PID output signal. Increasing DERIVATIVE TC decreases the damping, which in most cases causes overshoot and oscillations resulting in an unacceptable system response.

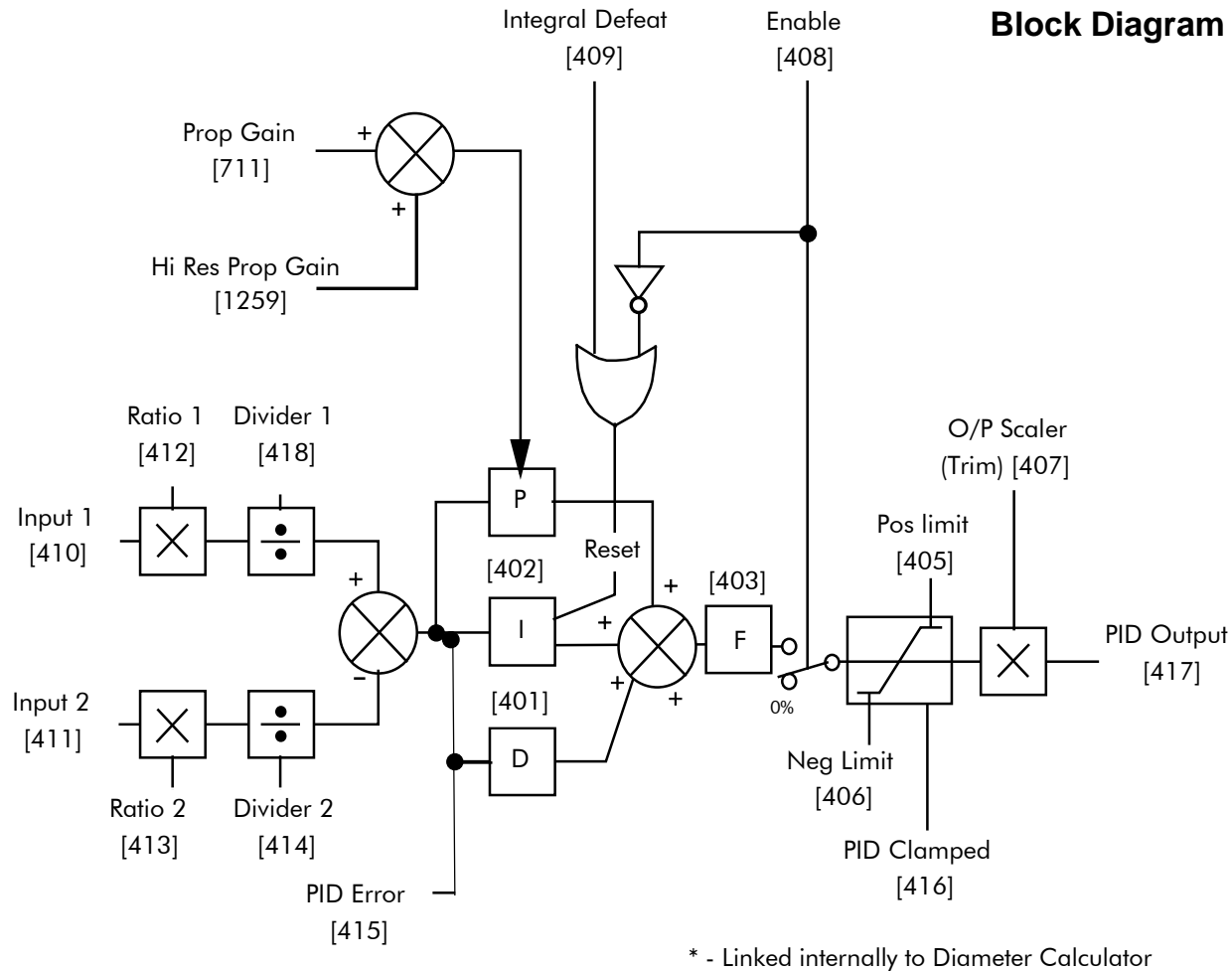
**NOTE** For most applications, derivative gain is never used and is usually left at its default value of 0.000 seconds.

Derivative gain can improve response in some dancer tension controlled systems, particularly those systems with high inertia dancers which need an instantaneous response to overcome the weight of the dancer roll. For loadcell controlled tension systems, derivative gain is almost *never* used.

- In underdamped systems, the output oscillates and the settling time increases.
- Critically damped systems have no overshoot or oscillations. They reach the setpoint within the desired response time.
- Overdamped systems do not oscillate but do not reach the setpoint within the desired response time.

**NOTE** The EMULATE 590P parameter in the CONFIGURE DRIVE function block affects the time constants used in the PID. If this parameter is non-zero, the filter, integral and derivative time constants used within the PID are four times greater than those shown on the input parameters. This emulates the behaviour of earlier versions of the 590P.





Operators can read the PID error, PID output, setpoint and feedback on the drive's MMI by monitoring the following values:

- PID ERROR : displayed in the DIAGNOSTICS menu
- PID OUTPUT : displayed in the DIAGNOSTICS menu
- SETPOINT : monitored at SETUP PARAMETERS::SPECIAL BLOCKS::PID::INPUT 1
- FEEDBACK : monitored at SETUP PARAMETERS::SPECIAL BLOCKS::PID::INPUT 2

**MMI Menu Map**

- 1 FUNCTION BLOCKS
- 2 MOTOR CONTROL
- 3 PLL
  - PLL STATE
  - PHASE ERROR
  - PLL MAINS FREQ

## PLL (PHASE LOCKED LOOP)

The phase locked loop function block allows the drive to ride through short disturbances to the supply voltage, frequency or phase and provides immunity to waveform distortion.

FUNCTION BLOCKS MOTOR CONTROL PLL

PLL STATE	[1198]	STOPPED
PHASE ERROR	[1199]	0.00
PLL MAINS FREQ	[1201]	0.00

### PLL (PHASE LOCKED LOOP)

Parameter	Tag	Range
-----------	-----	-------

<b>PLL STATE</b>	<b>1198</b>	<b>See below</b>
------------------	-------------	------------------

Indicates the current operating state of the phase locked loop function block. Normally the PLL will reside in the LOCKED state after close of the 3-phase line contactor. The FAIL state results if the supply frequency moves beyond the acceptable operating range.

- 0 : STOPPED
- 1 : 1ST CODING EDGE
- 2 : READ EDGES
- 3 : MAINS PERIOD
- 4 : LOCKED
- 5 : UNLOCKED
- 6 : FAIL

<b>PHASE ERROR</b>	<b>1199</b>	<b>—,xx</b>
--------------------	-------------	-------------

The instantaneous angle error between the zero-crossing detection of the line supply and the reference output from the PLL function block.

<b>PLL MAINS FREQ</b>	<b>1201</b>	<b>—,xx</b>
-----------------------	-------------	-------------

The measured 3-phase line supply frequency at the output of the PLL function block.

## PNO CONFIG

### MMI Menu Map

- 1 SERIAL LINKS
- 2 PNO CONFIG
  - PNO 112
  - PNO 113
  - PNO 114
  - PNO 115
  - PNO 116
  - PNO 117
  - PNO 118
  - PNO 119
  - PNO 120
  - PNO 121
  - PNO 122
  - PNO 123
  - PNO 124
  - PNO 125
  - PNO 126
  - PNO 127

The PNO parameters are used in conjunction with the EI ASCII and EI BINARY communications protocols.

Refer to Appendix A: "Serial Communications".

### FUNCTION BLOCKS\COMMUNICATIONS\PNO CONFIG

0	[312]	PNO 112
0	[313]	PNO 113
0	[314]	PNO 114
0	[315]	PNO 115
0	[316]	PNO 116
0	[317]	PNO 117
0	[318]	PNO 118
0	[319]	PNO 119
379	[320]	PNO 120
380	[321]	PNO 121
381	[322]	PNO 122
382	[323]	PNO 123
383	[324]	PNO 124
384	[325]	PNO 125
385	[326]	PNO 126
0	[327]	PNO 127

### PNO CONFIG

Parameter	Tag	Range
PNO 112 - 127	312 to 327	-1276 to 1276

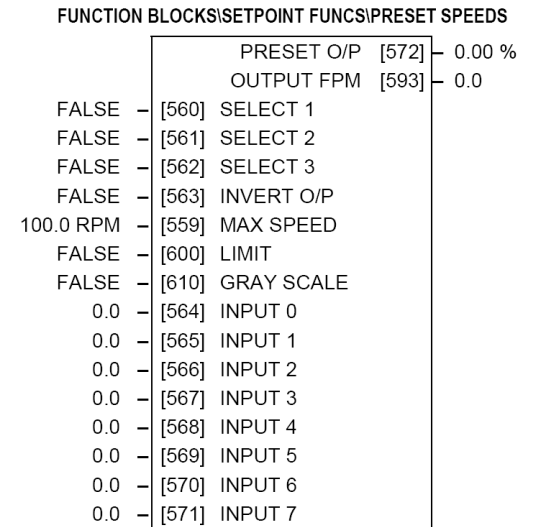
Indirect access parameters.

**MMI Menu Map**

- 1 SETUP PARAMETERS
- 2 PRESET SPEEDS
  - SELECT 1
  - SELECT 2
  - SELECT 3
  - INVERT O/P
  - MAX SPEED
  - LIMIT
  - GRAY SCALE
  - INPUT 0
  - INPUT 1
  - INPUT 2
  - INPUT 3
  - INPUT 4
  - INPUT 5
  - INPUT 6
  - INPUT 7
  - PRESET O/P
  - OUTPUT

## PRESET SPEEDS

The Preset Speeds block allows you to select one of eight preset inputs, which in turn may be connected to other blocks of inputs.

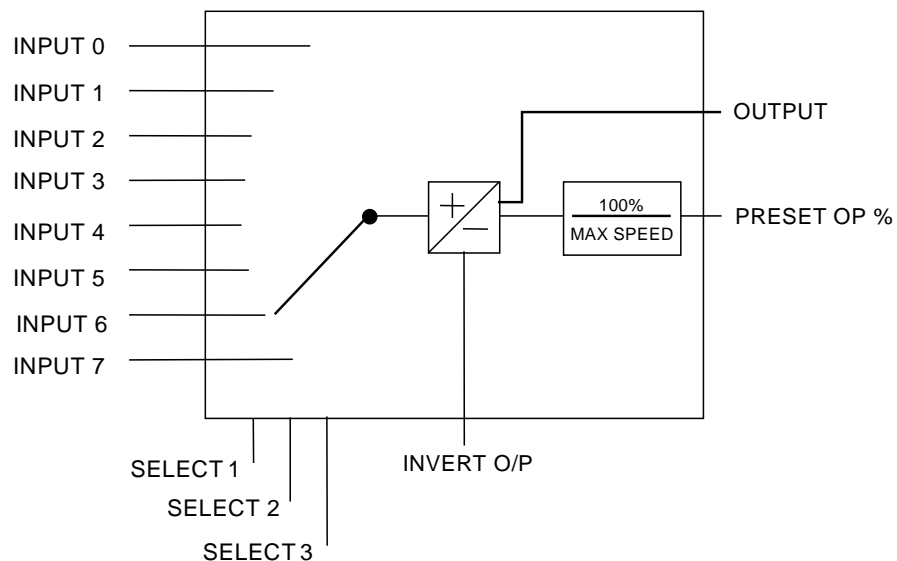


PRESET SPEEDS		
Parameter	Tag	Range
<b>SELECT 1</b>	<b>560</b>	<b>FALSE / TRUE</b>
Select inputs 1.		
<b>SELECT 2</b>	<b>561</b>	<b>FALSE / TRUE</b>
Select inputs 2.		
<b>SELECT 3</b>	<b>562</b>	<b>FALSE / TRUE</b>
Select inputs 3.		
<b>INVERT O/P</b>	<b>563</b>	<b>FALSE / TRUE</b>
Changes the sign of the output. If TRUE, the output is of the opposite sign to the selected input.		
<b>MAX SPEED</b>	<b>559</b>	<b>0.1 to 3000.0 RPM</b>
Scaler for PRESET OP (%).		

## PRESET SPEEDS

Parameter	Tag	Range
<b>LIMIT</b>	<b>600</b>	<b>FALSE / TRUE</b>
Clamp output to MAX SPEED if TRUE.		
<b>GRAY SCALE</b>	<b>610</b>	<b>FALSE / TRUE</b>
Selects Gray Scale encoding when TRUE, Binary encoding when FALSE. When gray scale is selected, only one input changes between state preventing the mis-selection of intermediate states.		
<b>INPUT 0 to INPUT 7</b>	<b>564, 565, 566, 567, 568, 569, 570, 571</b>	<b>-3000.0 to 3000.0</b>
Pre-set input variables.		
<b>PRESET O/P</b>	<b>572</b>	<b>—.xx %</b>
Scales the selected preset input by MAX SPEED.		
<b>OUTPUT FPM</b>	<b>593</b>	<b>—.x</b>
Outputs the selected INPUT value.		

## Functional Description



## Selection Table

Three Boolean variables used to select between one of the 8 preset values.

BINARY ENCODING			
Select 3	Select 2	Select 1	Input
FALSE	FALSE	FALSE	0
FALSE	FALSE	TRUE	1
FALSE	TRUE	FALSE	2
FALSE	TRUE	TRUE	3
TRUE	FALSE	FALSE	4
TRUE	FALSE	TRUE	5
TRUE	TRUE	FALSE	6
TRUE	TRUE	TRUE	7

GRAY SCALE ENCODING			
Select 3	Select 2	Select 1	Input
FALSE	FALSE	FALSE	0
FALSE	FALSE	TRUE	1
FALSE	TRUE	TRUE	2
FALSE	TRUE	FALSE	3
TRUE	TRUE	FALSE	4
TRUE	TRUE	TRUE	5
TRUE	FALSE	TRUE	6
TRUE	FALSE	FALSE	7

## PROFILED GAIN

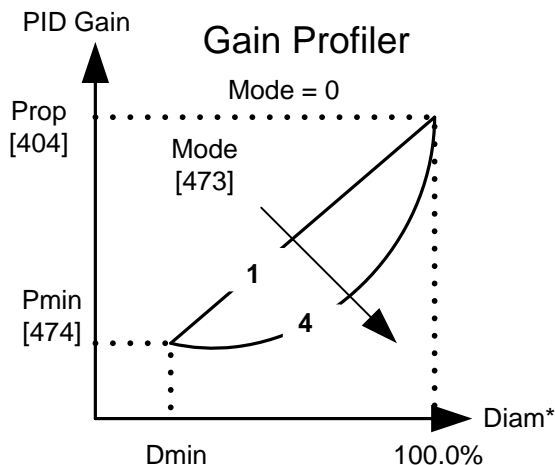
This function block may be used to profile the proportional gain input to the PID block.

### MMI Menu Map

- 1 SETUP PARAMETERS
- 2 SPECIAL BLOCKS
- 3 PID
  - PROP. GAIN
  - MODE
  - MIN PROFILE GAIN
  - PROFILED GAIN

### MMI Menu Map

- 1 FUNCTION BLOCKS
- 2 WINDER
- 3 PROFILED GAIN
  - DIAMETER
  - MIN DIAMETER



### FUNCTION BLOCKS|WINDER|PROFILED GAIN

- 1.0 - [475] PROFILED GAIN
- 20.00 % - [404] PROP. GAIN
- 10.00 % - [474] MIN PROFILE GAIN
- 10.00 % - [709] DIAMETER
- 0 - [710] MIN DIAMETER
- 0 - [473] MODE

## PROFILED GAIN

Parameter	Tag	Range
<b>PROP. GAIN</b>	<b>404</b>	<b>0.0 to 100.0</b>
The nominal gain prior to profiling.		
<b>MIN PROFILE GAIN</b>	<b>474</b>	<b>0.00 to 100.00 %</b>
This expresses the minimum gain required at minimum diameter (core) as a percentage of the (maximum) P gain at full diameter (100%), when MODE > 0.		
<b>DIAMETER</b>	<b>709</b>	<b>0.00 to 100.00 %</b>
The actual measured diameter. If appropriate, this may be connected to the DIAMETER output parameter in the DIAMETER CALC function block.		
<b>MIN DIAMETER</b>	<b>710</b>	<b>0.00 to 100.00 %</b>
Set to the minimum core diameter (normally the empty core diameter) as a percentage of the maximum roll diameter. If appropriate, this may be connected to the MIN DIAMETER parameter in the DIAMETER CALC function block.		

**PROFILED GAIN**

Parameter	Tag	Range
-----------	-----	-------

<b>MODE</b>	<b>473</b>	<b>0 to 4</b>
-------------	------------	---------------

This determines the shape of the proportional gain profile. The higher the setting, the steeper the curve of the profiled gain.

For Mode = 0, Profiled Gain = constant = P.

For Mode = 1, Profiled Gain = A \* (diameter - min diameter) + B.

For Mode = 2, Profiled Gain = A \* (diameter - min diameter)<sup>2</sup> + B.

For Mode = 3, Profiled Gain = A \* (diameter - min diameter)<sup>3</sup> + B.

For Mode = 4, Profiled Gain = A \* (diameter - min diameter)<sup>4</sup> + B.

<b>PROFILED GAIN</b>	<b>475</b>	<b>—x</b>
----------------------	------------	-----------

The proportional gain after profiling by a profiler block which varies the gain versus diameter. This is primarily to be used with Speed Profiled Winders for compensation against varying diameter and therefore inertia.

- When MODE is not ZERO (see above) this overrides the P gain above.
- When MODE = 0, then PROFILED GAIN = PROP. GAIN.



## RAISE/LOWER

This function block acts as an internal motorised potentiometer (MOP).

The OUTPUT is not preserved when the drive is powered-down.

FUNCTION BLOCKS	SETPOINT FUNCS	RAISE/LOWER
		RAISE/LOWER O/P [264] — 0.00 %
0.00 %	[255]	RESET VALUE
10.0 s	[256]	INCREASE RATE
10.0 s	[257]	DECREASE RATE
FALSE	[261]	RAISE INPUT
FALSE	[262]	LOWER INPUT
-100.00 %	[258]	MIN VALUE
100.00 %	[259]	MAX VALUE
FALSE	[307]	EXTERNAL RESET

### MMI Menu Map

1 SETUP PARAMETERS

2 RAISE/LOWER

- RESET VALUE
- INCREASE RATE
- DECREASE RATE
- RAISE INPUT
- LOWER INPUT
- MIN VALUE
- MAX VALUE
- EXTERNAL RESET

### MMI Menu Map

1 FUNCTION BLOCKS

2 SETPOINT FUNCS

3 RAISE/LOWER

- RAISE/LOWER O/P

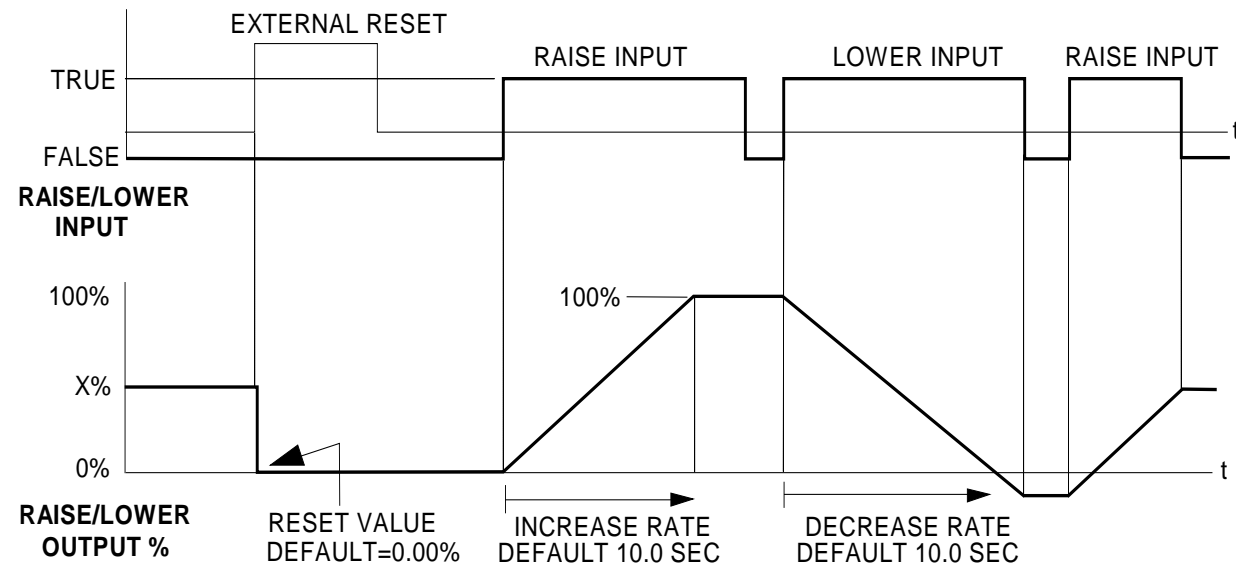
## RAISE/LOWER

Parameter	Tag	Range
<b>RAISE/LOWER O/P</b>	<b>264</b>	<b>— .xx %</b>
The output value.		
<b>RESET VALUE</b>	<b>255</b>	<b>-300.00 to 300.00 %</b>
This reset value is pre-loaded directly into the output when EXTERNAL RESET is TRUE, or at power-up. It is clamped by MIN VALUE and MAX VALUE.		
<b>INCREASE RATE</b>	<b>256</b>	<b>0.1 to 600.0 s</b>
Rate of change of an increasing output value. An increasing value is defined as the output ramping away from zero.		
<b>DECREASE RATE</b>	<b>257</b>	<b>0.1 to 600.0 s</b>
Rate of change of a decreasing output value. A decreasing value is defined as the output ramping towards zero.		
<b>RAISE INPUT</b>	<b>261</b>	<b>FALSE / TRUE</b>
Command to raise the output value. When TRUE, increases the output at the rate determined by INCREASE RATE.		
<b>LOWER INPUT</b>	<b>262</b>	<b>FALSE / TRUE</b>
Command to lower the output value. When TRUE, decreases the output at the rate determined by DECREASE RATE.		

## RAISE/LOWER

Parameter	Tag	Range
<b>MIN VALUE</b>	<b>258</b>	<b>-300.00 to 300.00 %</b>
Minimum ramp output clamp. This is a plain clamp, not a ramped "min speed" setting.		
<b>MAX VALUE</b>	<b>259</b>	<b>-300.00 to 300.00 %</b>
Maximum ramp output clamp.		
<b>EXTERNAL RESET</b>	<b>307</b>	<b>FALSE / TRUE</b>
When TRUE, sets the output of the Raise/Lower block to the RESET VALUE.		

## Functional Description



The diagram above illustrates the raise/lower functionality.

## D-102 Programming

When EXTERNAL RESET is set TRUE, the raise/lower output resets to RESET VALUE (default = 0.00%).

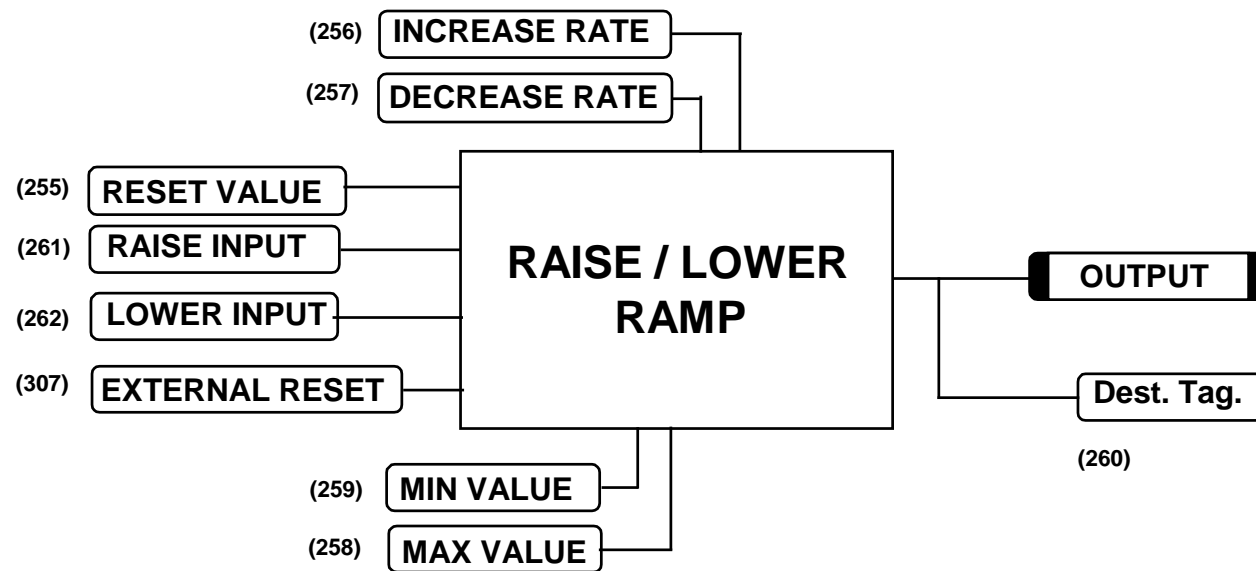
When RAISE INPUT is TRUE, the output increases at INCREASE RATE. The output cannot exceed MAX VALUE.

The reverse is true when LOWER INPUT is TRUE: LOWER INPUT reduces the output at DECREASE RATE. The output cannot drop below MIN VALUE.

The ramp is held at its last value when the RAISE and LOWER INPUT are removed.

Setting both RAISE INPUT and LOWER INPUT to TRUE at the same time creates a ramp hold condition.

If MIN VALUE is greater than MAX VALUE the output is forced to zero.



If Reset, Output = Reset Value (Clamped)

**MMI Menu Map**

- 1 SETUP PARAMETERS
  - 2 RAMPS
    - RAMP ACCEL TIME
    - RAMP DECEL TIME
    - RAMP HOLD
    - INVERT
    - % S-RAMP
    - RAMPING THRESH.
    - AUTO RESET
    - EXTERNAL RESET
    - RESET VALUE

**MMI Menu Map**

- 1 FUNCTION BLOCKS
  - 2 SEQ & REF
    - 3 RAMPS
      - RAMP INPUT

**MMI Menu Map**

- 1 DIAGNOSTICS
  - RAMPING
  - RAMP OUTPUT

## RAMPS

The RAMPS parameters set the shape and duration of the ramp used for starting and changing speeds.

**NOTE** The STOP RATES function block contains a separate deceleration rate for controlled stopping of the drive.

By default the inputs are ANIN 3 (A4) for a ramped speed input, and DIGIN 2 (C7) to switch RAMP HOLD. The input signal to the block is clamped by MIN SPEED, which sets the minimum ramp input speed when the drive is enabled. The default output connection is to SPEED LOOP:: SETPOINT 3.

RAMP INPUT is internally routed to the JOG/SLACK function block to be modified as determined by the JOG inputs. The RAMPS block then shapes the signal to produce the RAMP OUTPUT signal.

The RAMPING output becomes TRUE when the absolute value of the difference between RAMP OUTPUT and the JOG/SLACK function block output exceeds RAMPING THRESH.

RAMP ACCEL TIME and RAMP DECEL TIME set the acceleration and deceleration times taken for input changes. % S-RAMP adds a "S" shaped section to the linear ramp. When set to 0.00%, the ramp will be linear. As the percentage is increased, 350% of the S-RAMP time is added to the linear ramp creating more gradual starting and stopping. The formula for the actual ramp time is shown below. Ramp time is the value of parameters RAMP ACCEL TIME or RAMP DECEL TIME.

$$Actual\ Ramp\ Time = RAMP\ TIME \times (3.5 \times \% S-RAMP / 100 + 1)$$

RAMP HOLD stops the ramp from changing. When DIGIN 2 (C7) is ON, the ramp stays at the last ramp value.

The reset signal can have two sources, a RUN signal or an external reset signal. When AUTO RESET is ENABLED, the ramp resets whenever a Run signal is given at terminal C3. Connecting a digital input to EXTERNAL RESET allows an external source to reset the ramp.

FUNCTION BLOCKS: SEQ & REF: RAMPS

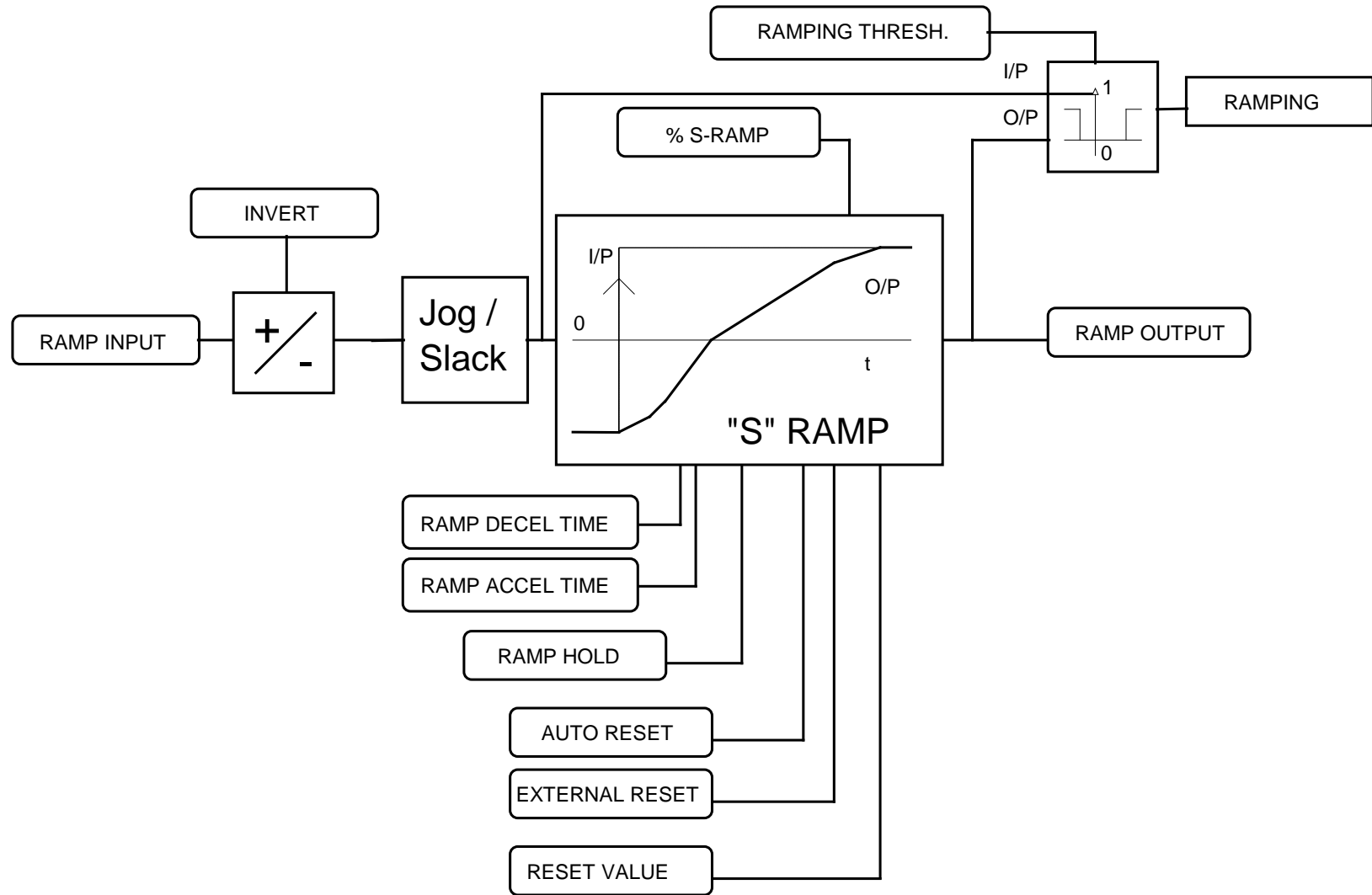
	RAMP OUTPUT [ 85]	0.00 %
	RAMPING [113]	FALSE
10.0 s	[ 2] RAMP ACCEL TIME	
10.0 s	[ 3] RAMP DECEL TIME	
OFF	[118] RAMP HOLD	
FALSE	[620] INVERT	
0.00 %	[697] RAMP INPUT	
2.50 %	[266] % S-RAMP	
0.50 %	[286] RAMPING THRESH.	
ENABLED	[287] AUTO RESET	
DISABLED	[288] EXTERNAL RESET	
0.00 %	[422] RESET VALUE	

## RAMPS

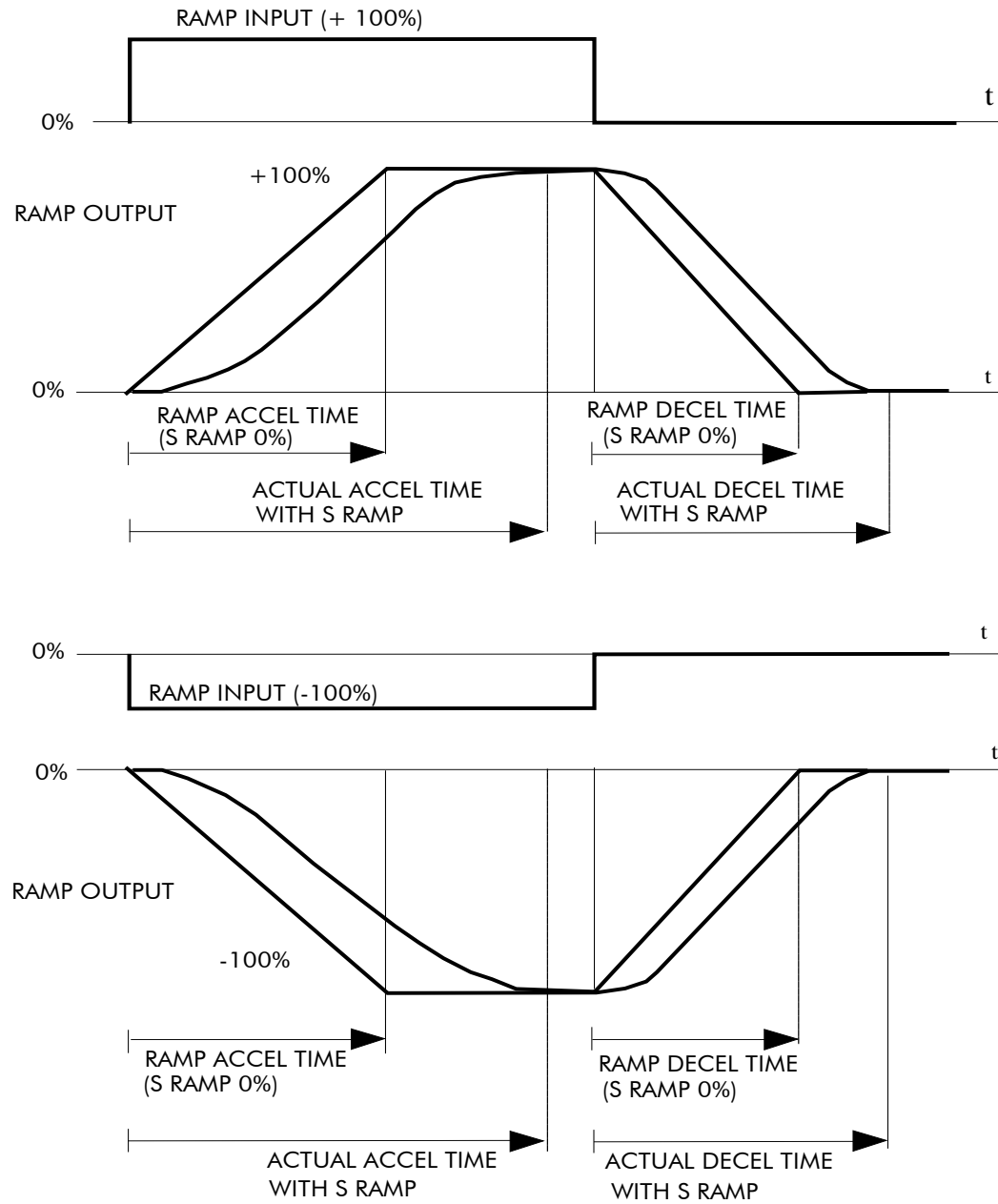
Parameter	Tag	Range
<b>RAMP ACCEL TIME</b>	<b>2</b>	<b>0.1 to 600.0 s</b>
The acceleration time for 100% change.		
<b>RAMP DECEL TIME</b>	<b>3</b>	<b>0.1 to 600.0 s</b>
The deceleration time for 100% change.		

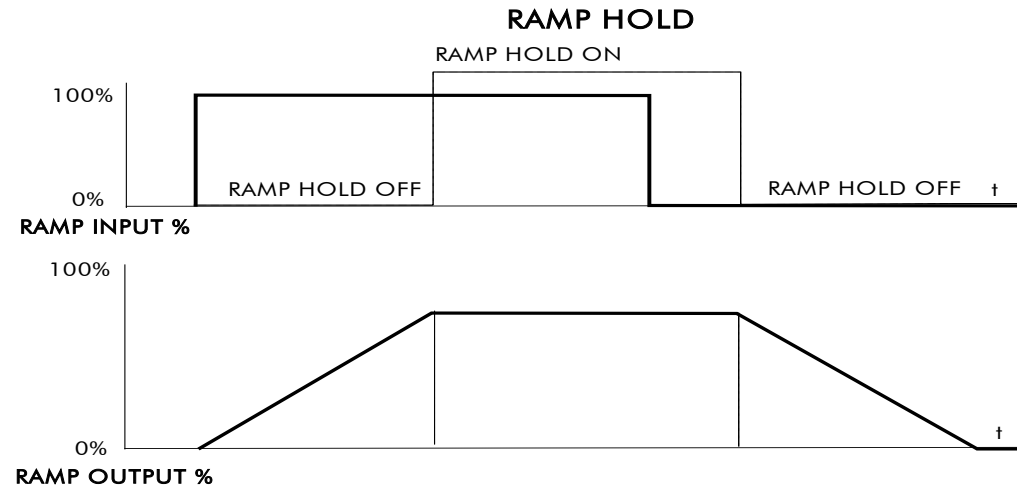
<b>RAMPS</b>		
<b>Parameter</b>	<b>Tag</b>	<b>Range</b>
<b>RAMP HOLD</b>	<b>118</b>	<b>OFF / ON</b>
When ON, the ramp output is held at its last value. This is overridden by a ramp reset.		
<b>INVERT</b>	<b>620</b>	<b>FALSE / TRUE</b>
Inverts the RAMP INPUT signal.		
<b>RAMP INPUT</b>	<b>5</b>	<b>-105.00 to 105.00 %</b>
Input value.		
<b>% S-RAMP</b>	<b>266</b>	<b>0.00 to 100.00 %</b>
Percentage of ramp with S-shaped rate of change. A value of zero is equivalent to a linear ramp. Changing this value affects the ramp times.		
<b>RAMPING THRESH.</b>	<b>286</b>	<b>0.00 to 100.00 %</b>
Ramping flag threshold level. The threshold is used to detect whether the ramp is active.		
<b>AUTO RESET</b>	<b>287</b>	<b>DISABLED / ENABLED</b>
When ENABLED, the ramp is reset whenever SYSTEM RESET is TRUE. (SYSTEM RESET Tag 374 is an internal flag that is set TRUE for one cycle after the Speed/Current loop is enabled, i.e. every time the drive is started).		
<b>EXTERNAL RESET</b>	<b>288</b>	<b>DISABLED / ENABLED</b>
When ENABLED, the ramp is reset to RESET VALUE. EXTERNAL RESET does not depend on AUTO RESET for its operation.		
<b>RESET VALUE</b>	<b>422</b>	<b>-300.00 to 300.00 %</b>
The ramp output value at power-up, or when the ramp is reset. In order to catch a spinning load smoothly ('bumpless transfer') connect SPEED FEEDBACK Tag No. 62 (source) to RESET VALUE Tag No. 422 (destination).		
<b>RAMP OUTPUT</b>	<b>85</b>	<b>—,xx %</b>
Setpoint ramp output.		
<b>RAMPING</b>	<b>113</b>	<b>FALSE / TRUE</b>
The SETPOINT ramp function block is limiting the rate of change of Speed Setpoint.		

## Functional Description

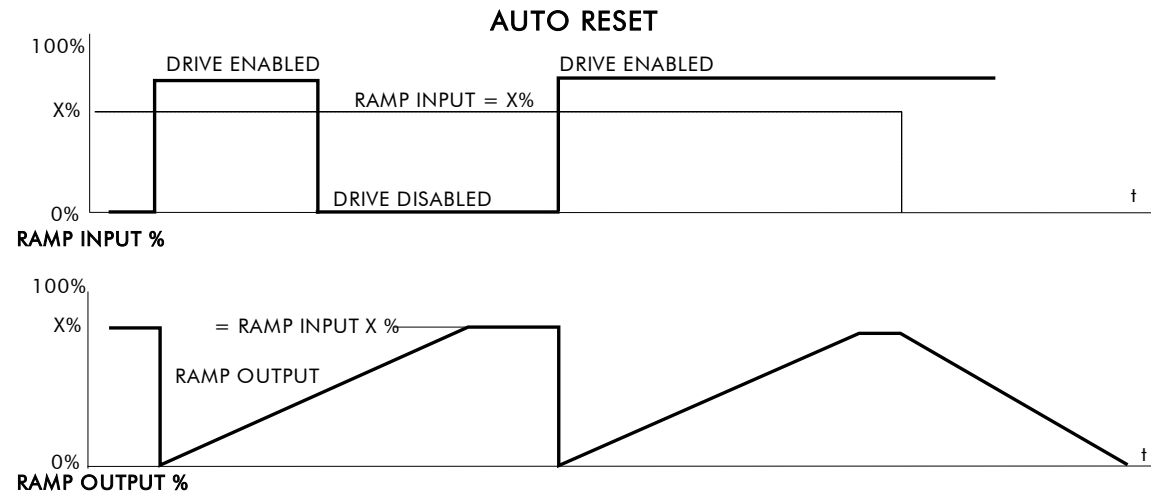


### ACCELERATION/DECELERATION RATES



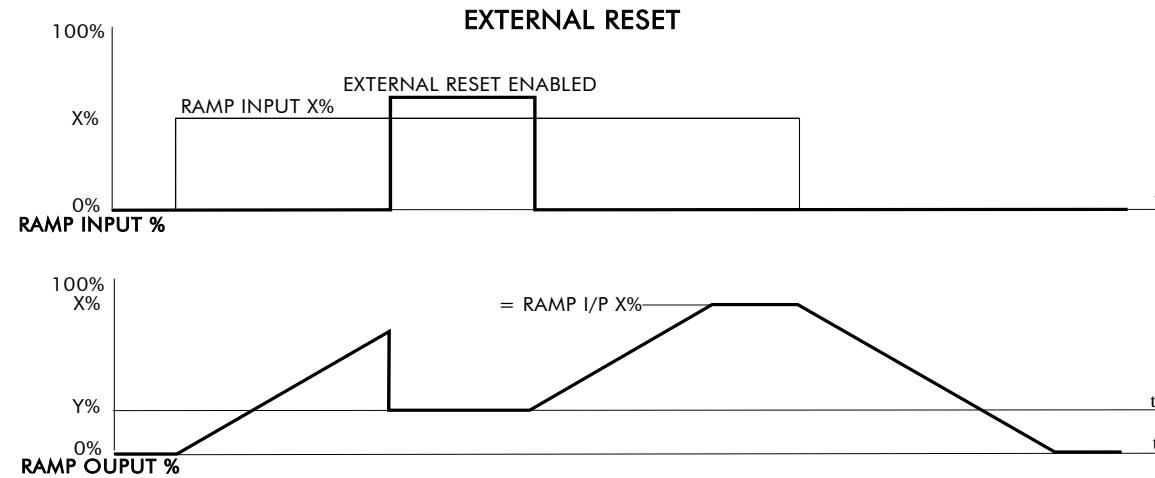


The ramp will function when a ramp input is present. When DIGIN 2 (C7) is ON, RAMP HOLD stops the ramp from changing. Even when the ramp input signal is removed, RAMP HOLD keeps the ramp output from changing. Once RAMP HOLD is OFF, the ramp resumes.



When AUTO RESET is ENABLED, ramp output resets to RESET VALUE each time the drive is enabled. In this example RESET VALUE is 0.00%. It does not reset if the drive is disabled.





The ramp input is set to X% at time  $t_0$ . The ramp output will increase at the ramp rate. While EXTERNAL RESET is ENABLED, the ramp output resets to RESET VALUE (Y%). When EXTERNAL RESET is DISABLED, the ramp output continues to follow the input signal.

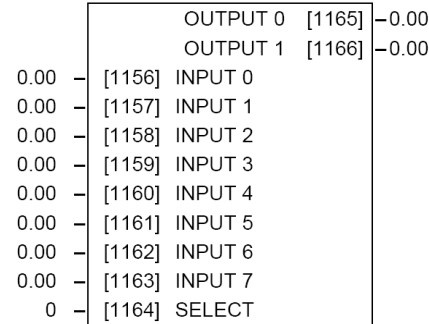
**MMI Menu Map**

- 1 FUNCTION BLOCKS
- 2 SETPOINT FUNCS
- 3 SELECT
- 4 SELECT 1
- 4 SELECT 2
  - INPUT 0
  - INPUT 1
  - INPUT 2
  - INPUT 3
  - INPUT 4
  - INPUT 5
  - INPUT 6
  - INPUT 7
  - SELECT
  - OUTPUT 0
  - OUTPUT 1

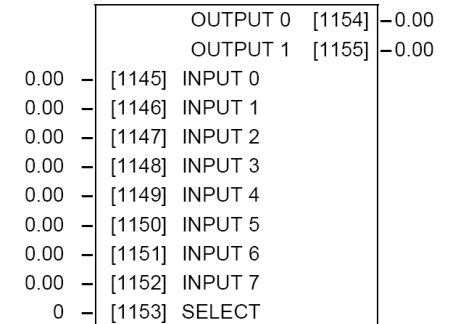
## SELECT

Used to select a value from one of eight inputs, depending on the value of the select input. A second output is provided to allow the block to be used as two banks of four inputs.

FUNCTION BLOCKS\SETPOINT FUNCS\SELECT\SELECT 1



FUNCTION BLOCKS\SETPOINT FUNCS\SELECT\SELECT 2



### SELECT

Parameter	Tag	Range
<b>INPUT 0 to INPUT 7</b>	<b>1156 to 1163</b>	<b>-32768.00 to 32768.00</b>
Inputs to the select block		
<b>SELECT</b>	<b>1164</b>	<b>0 to 7</b>
Determines which of the inputs is routed to OUTPUT 1 . In addition, if SELECT INPUT is in the range 0 to 3, INPUT 4 to INPUT 7 respectively is routed to OUTPUT 2, otherwise OUTPUT 2 is unchanged.		
<b>OUTPUT 0</b>	<b>1165</b>	<b>—.xx</b>
Selected output		
<b>OUTPUT 1</b>	<b>1166</b>	<b>—.xx</b>
Alternative selected output from INPUT 4 to INPUT 7 if SELECT is less than 4.		

# SEQUENCING

This function block contains all the parameters relating to the sequencing (start and stop) of the drive.

### MMI Menu Map

- 1 SETUP PARAMETERS
- 2 AUX I/O
  - AUX START
  - AUX JOG
  - AUX ENABLE
  - JOG SLACK
  - ENABLE
  - REM.SEQ.ENABLE
  - REM. SEQUENCE
  - SEQ STATUS

### MMI Menu Map

- 1 DIAGNOSTICS
  - PROGRAM STOP
  - COAST STOP
  - DRIVE START
  - DRIVE ENABLE
  - START (C3)
  - CONTACTOR CLOSED
  - READY
  - DRIVE RUNNING
  - SYSTEM RESET

### MMI Menu Map

- 1 FUNCTION BLOCKS
- 2 SEQ & REF
- 3 SEQUENCING
  - COMMS TIMEOUT
  - SEQ STATE

### FUNCTION BLOCKS/SEQ & REF/SEQUENCING

SEQ STATUS [537]	-	0x0000
DRIVE START [82]	-	OFF
CONTACTOR CLOSED [83]	-	FALSE
DRIVE ENABLE [84]	-	FALSE
DRIVE RUNNING [376]	-	FALSE
SYSTEM RESET [374]	-	FALSE
READY [125]	-	FALSE
SEQ STATE [114]	-	SEQ INIT
START (C3) [68]	-	OFF
PROGRAM STOP [80]	-	FALSE
COAST STOP [525]	-	FALSE
ON - [161]	AUX START	
ON - [227]	AUX JOG	
ON - [168]	AUX ENABLE	
OFF - [496]	JOG/SLACK	
OFF - [497]	ENABLE	
OFF - [535]	REM.SEQ.ENABLE	
0x8000 - [536]	REM.SEQUENCE	
0.0 s - [1204]	COMMS TIMEOUT	

## SEQUENCING

Parameter	Tag	Range
<b>AUX START</b>	<b>161</b>	<b>OFF / ON</b>
Software Start/Run command. Auxiliary Start is ANDed with the Start input, C3, to generate Drive Start. This should normally be left ON.		
<b>AUX JOG</b>	<b>227</b>	<b>OFF / ON</b>
Software Jog command. Auxiliary Jog is ANDed with the Jog input, Tag 496 (by default C4), to generate Drive Jog. This should normally be left ON.		
<b>AUX ENABLE</b>	<b>168</b>	<b>OFF / ON</b>
Software Enable command. Auxiliary Enable is ANDed with the Enable input, Tag 497 (by default C5), to generate Drive Enable. This should normally be left ON.		

**SEQUENCING**

Parameter	Tag	Range
<b>JOG/SLACK</b>	<b>496</b>	<b>OFF / ON</b>
Main jog input which is connected to DIGITAL INPUT C4 by default. The Jog input is ANDed with Auxiliary Jog input, Tag 227, to generate Drive Jog.		
<b>ENABLE</b>	<b>497</b>	<b>OFF / ON</b>
Enable input which is connected to DIGITAL INPUT C5 by default. The Enable input is ANDed with Auxiliary Enable input, Tag 168, to generate Drive Enable.		
<b>REM.SEQ.ENABLE</b>	<b>535</b>	<b>FALSE / TRUE</b>
(Refer to Chapter 4: "External Control of the Drive"). When enabled, the drive will accept Sequencing commands exclusively from the REM. SEQUENCE parameter, Tag 536.		
FALSE - disables REM. SEQUENCE TRUE - enables REM. SEQUENCE		
<b>REM.SEQUENCE</b>	<b>536</b>	<b>0x0000 to 0xFFFF</b>
A control word that allows the device to be operated remotely over a field bus. REM. SEQ. ENABLE must be TRUE to enable this function. (Refer to Chapter 4: "External Control of the Drive").		
<b>COMMS TIMEOUT</b>	<b>1204</b>	<b>0.0 to 60.0 s</b>
A watchdog timeout that may be used when the drive is in remote sequencing mode. The watchdog feature is enabled by selecting a non-zero time in this parameter. The watchdog is reset every time the REM.SEQUENCE word, (Tag 536), is written.		
<b>SEQ STATUS</b>	<b>537</b>	<b>0x0000 to 0xFFFF</b>
An data word that reports the status of the important system flags that can be read over a field bus. (Refer to Chapter 4: "External Control of the Drive").		
<b>DRIVE START</b>	<b>82</b>	<b>OFF / ON</b>
Logical OR of the START and JOG inputs.		
<b>CONTACTOR CLOSED</b>	<b>83</b>	<b>FALSE / TRUE</b>
When ON, the main contactor coil is energised. Refer to Terminal Information for D5 & D6 in Appendix E: "Technical Specifications" - Terminal Information.		
<b>DRIVE ENABLE</b>	<b>84</b>	<b>FALSE / TRUE</b>
Drive speed and current loop are enabled/quenched.		
<b>DRIVE RUNNING</b>	<b>376</b>	<b>FALSE / TRUE</b>
When TRUE, the stack is switched on and enabled.		

<b>SEQUENCING</b>		
<b>Parameter</b>	<b>Tag</b>	<b>Range</b>
<b>SYSTEM RESET</b> Set for one cycle as the drive is enabled.	<b>374</b>	<b>FALSE / TRUE</b>
<b>READY</b> The drive is ready to accept an enable signal.	<b>125</b>	<b>FALSE / TRUE</b>
<b>SEQ STATE</b> 0: SEQ INIT 1: SEQ INIT 2: SEQ HOLD 3: SEQ STANDBY 4: SEQ PRE READY 5: SEQ READY 6: SEQ AUTOTUNING 7: SEQ RUN 8: SEQ AT ZERO SPD. 9: SEQ QUENCH 10: SEQ PROGRAM STOP 11: SEQ STOP 12: SEQ DELAY STOP 13: CURRENT DECAY 14: SEQ COAST STOP 15: SEQ ERROR	<b>114</b>	<b>See below</b>
<b>START (C3)</b> State of the Start/Run terminal.	<b>68</b>	<b>OFF / ON</b>
<b>PROGRAM STOP</b> State of program stop (Terminal B8). When B8 is at 24V, then PROGRAM STOP is FALSE.	<b>80</b>	<b>FALSE / TRUE</b>
<b>COAST STOP</b> State of coast stop (Terminal B9). When B9 is at 24V, then COAST STOP is FALSE.	<b>525</b>	<b>FALSE / TRUE</b>

## SETPOINT SUM

Use this menu to sum and scale up to three analog inputs to produce the SPT. SUM output.

INPUT 0 and INPUT 1 have individual ratio and divider scalars, and signs. The inputs have symmetrical limits set by LIMIT. INPUT 2 has no scaling or limits.

The output, after INPUT 0, INPUT 1 and INPUT 2 are summed, is also clamped by LIMIT before producing the SPT. SUM output.

FUNCTION BLOCKS\SETPOINT FUNCS\SETPOINT SUM\SETPOINT SUM 1	FUNCTION BLOCKS\SETPOINT FUNCS\SETPOINT SUM\SETPOINT SUM 2
SPT SUM OUTPUT [ 86] - 0.00 %	SPT SUM OUTPUT [451] - 0.00 %
STPT SUM 1 OUT 1 [702] - 0.00 %	STPT SUM 2 OUT 1 [492] - 0.00 %
STPT SUM 1 OUT 0 [703] - 0.00 %	STPT SUM 2 OUT 0 [491] - 0.00 %
0.00 % - [309] INPUT 0	0.00 % - [444] INPUT 0
0.00 % - [701] INPUT 1	0.00 % - [443] INPUT 1
0.00 % - [423] INPUT 2	0.00 % - [445] INPUT 2
1.0000 - [ 6] RATIO 1	1.0000 - [446] RATIO 1
1.0000 - [208] RATIO 0	1.0000 - [447] RATIO 0
1.0000 - [419] DIVIDER 1	1.0000 - [466] DIVIDER 1
1.0000 - [420] DIVIDER 0	1.0000 - [448] DIVIDER 0
POSITIVE - [ 8] SIGN 1	POSITIVE - [704] SIGN 1
POSITIVE - [292] SIGN 0	POSITIVE - [705] SIGN 0
105.00 % - [375] LIMIT	105.00 % - [449] LIMIT

### MMI Menu Map

- 1 SETUP PARAMETERS
- 2 SETPOINT SUM 1
  - RATIO 1
  - RATIO 0
  - SIGN 1
  - SIGN 0
  - DIVIDER 1
  - DIVIDER 0
  - LIMIT
  - INPUT 2
  - INPUT 1
  - INPUT 0

### MMI Menu Map

- 1 FUNCTION BLOCKS
- 2 SETPOINT FUNCS
- 3 SETPOINT SUM
- 4 SETPOINT SUM 1
  - SPT SUM OUTPUT
  - STPT SUM 1 OUT 1
  - STPT SUM 1 OUT 0

SETPOINT SUM		
Parameter	Tag	Range
<b>INPUT 0</b> Input 0 value.	<b>309</b>	<b>-300.00 to 300.00 %</b>
<b>INPUT 1</b> Input 1 value.	<b>701</b>	<b>-300.00 to 300.00 %</b>
<b>INPUT 2</b> Input 2 value.	<b>423</b>	<b>-300.00 to 300.00 %</b>
<b>RATIO 1</b> Multiplier term for INPUT 1.	<b>6</b>	<b>-3.0000 to 3.0000</b>
<b>RATIO 0</b> Multiplier term for INPUT 0.	<b>208</b>	<b>-3.0000 to 3.0000</b>
<b>DIVIDER 1</b> Divider scaling for INPUT 1. Dividing by 0 (zero) results in a zero output.	<b>419</b>	<b>-3.0000 to 3.0000</b>
<b>DIVIDER 0</b> Divider scaling for INPUT 0. Dividing by 0 (zero) results in a zero output.	<b>420</b>	<b>-3.0000 to 3.0000</b>
<b>SIGN 1</b> Polarity for INPUT 1.	<b>8</b>	<b>NEGATIVE / POSITIVE</b>
<b>SIGN 0</b> Polarity for INPUT 0.	<b>292</b>	<b>NEGATIVE / POSITIVE</b>

**MMI Menu Map**

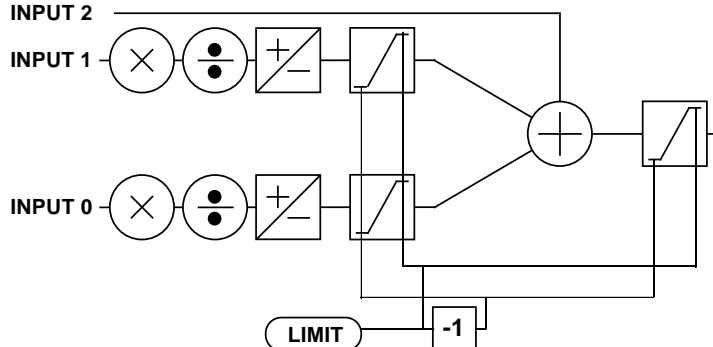
- 1 FUNCTION BLOCKS
- 2 SETPOINT FUNCS
- 3 SETPOINT SUM
- 4 SETPOINT SUM 2
  - INPUT 0
  - INPUT 1
  - INPUT 2
  - RATIO 1
  - RATIO 0
  - DIVIDER 1
  - DIVIDER 0
  - SIGN 1
  - SIGN 0
  - LIMIT
  - SPT SUM OUTPUT
  - STPT SUM 2 OUT 1
  - STPT SUM 2 OUT 0

## SETPOINT SUM

Parameter	Tag	Range
-----------	-----	-------

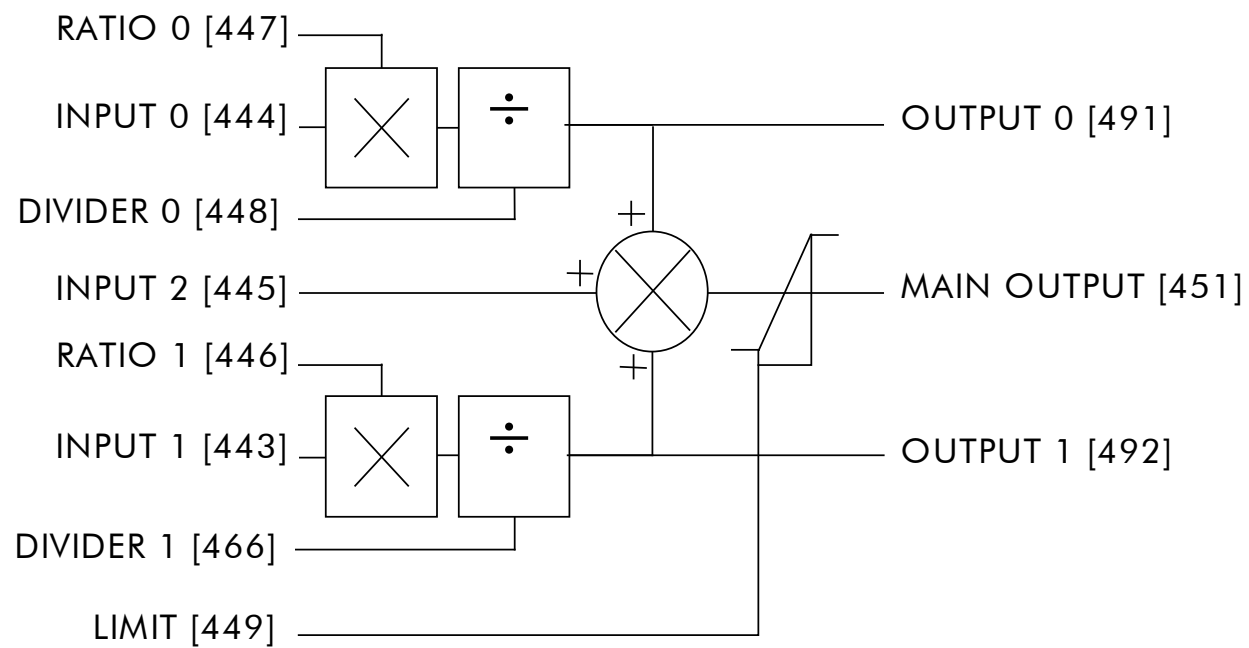
**LIMIT** **375** **0.00 to 200.00 %**

The Setpoint Sum programmable limit is symmetrical and has the range 0.00% to 200.00%. The limit is applied both to the intermediate results of the RATIO calculation and the total output.



<b>SPT SUM OUTPUT</b>	<b>86</b>	<b>—.xx %</b>
The sum of input 0, 1 and 2 after the limit clamp.		
<b>STPT SUM 1 OUT 1</b>	<b>702</b>	<b>—.xx %</b>
An additional output provided to gain access to Input 1 channel sub-calculations. The result of (INPUT 1 x RATIO 1) / DIVIDER 1 clamped to within ± LIMIT.		
<b>STPT SUM 1 OUT 0</b>	<b>703</b>	<b>—.xx %</b>
An additional output provided to gain access to Input 0 channel sub-calculations. The result of (INPUT 0 x RATIO 0) / DIVIDER 0 clamped to within ± LIMIT.		

## Functional Description





## SPEED LOOP

Use this block to tune the speed loop PI to produce a current demand.

This function block has five main functions:

### 1. Combining the 4 speed setpoints into a single speed setpoint.

Note that the speed demand is created from the combined speed setpoints and modified by any prevailing stop condition according to the STOP RATES function block settings.

### 2. Selection of the speed feedback method.

ZERO SPD OFFSET from the CALIBRATION function block is applied to the selected speed feedback to null out any remaining feedback at zero actual speed.

### 3. Implementation of the PI speed controller.

SPEED DEMAND is summed algebraically with SPEED FEEDBACK to produce SPEED ERROR. When the drive is enabled, SPEED ERROR is controlled by the PI loop. The resulting current demand signal is routed to the CURRENT LOOP function block and to the ADVANCED::ZERO SPD. QUENCH sub-menu.

The PI output is accessible via Tag No. 356, TOTAL I DMD. This point is before the I Limit clamps and the summing of the additional current demand. (This tag is not visible on the MMI).

### 4. Speed controller gain and integral time constant profiling with speed.

The gains change when the motor speed feedback reaches the thresholds set by SPD BRK 1 (LOW) and SPD BRK 2 (HIGH).

- At or below SPD BRK 1 (LOW), the speed loop uses the PROP. GAIN and INT. TIME CONST. values as its PI loop gains.
- Between SPD BRK 1 (LOW) and SPD BRK 2 (HIGH), profiling occurs and the speed loop gains are determined by another parameter value (according to the selection of the MODE parameter).
- Above SPD BRK 2 (HIGH), the SPD. PROP. GAIN and SPD. INT. TIME settings are used.

MODE selects the parameter for profiling the speed loop PI gains when the motor speed is between the two speed breakpoints.

### FUNCTION BLOCKS/MOTOR CONTROL/SPEED LOOP

SPEED ERROR FILTERED	[297]	0.00 %
SPEED LOOP O/P	[549]	0.00 %
SPEED DEMAND	[ 89]	0.00 %
UNFIL.SP.D.FBK	[ 62]	0.00 %
SPEED SETPOINT	[ 63]	0.00 %
UNFIL.SP.D.ERROR	[ 64]	0.00 %
SETPOINT 2 (A3)	[290]	0.00 %
10.00	[ 14]	SPD PROP GAIN
0.500 s	[ 13]	SPD INT TIME
OFF	[202]	INT. DEFEAT
0.000	[547]	SPD.FBK.FILTER
0.00 %	[289]	SETPOINT 1
POSITIVE	[ 9]	SIGN 2 (A3)
1.0000	[ 7]	RATIO 2 (A3)
0.00 %	[291]	SETPOINT 3
0.00 %	[ 41]	SETPOINT 4
105.00 %	[357]	MAX DEMAND
-105.00 %	[358]	MIN DEMAND
0.00 %	[595]	PRESET TORQUE
100.00 %	[604]	PRESET T SCALE
DISABLED	[268]	MODE
1.00 %	[269]	SPD BRK1 (LOW)
5.00 %	[270]	SPD BRK2 (HIGH)
5.00	[271]	PROP. GAIN
0.500 s	[272]	INT TIME CONST
1.0000	[274]	I GAIN IN RAMP
0.50 %	[284]	ZERO SPD. LEVEL
1.50 %	[285]	ZERO IAD LEVEL
ARM VOLTS FBK	[ 47]	SPEED FBK SELECT

**MMI Menu Map**

1	SETUP PARAMETERS
2	SPEED LOOP
	SPD.PROP.GAIN
	SPD.INT.TIME
	INT. DEFEAT
	PRESET TORQUE
	PRESET T SCALE
	SPEED FBK SELECT
	ENCODER SIGN
	SPD.FBK.FILTER
>>	ADVANCED
>>	SETPOINTS

**MMI Menu Map**

1	SETUP PARAMETERS
2	SPEED LOOP
3	SETPOINTS
	SETPOINT 1
	SIGN 2 (A3)
	RATIO 2 (A3)
	SETPOINT 2 (A3)
	SETPOINT 3
	SETPOINT 4
	MAX DEMAND
	MIN DEMAND

**5. Zero speed/current disabling of thyristor firing**

The current loop is disabled when SPEED DEMAND, SPEED FEEDBACK and CURRENT DEMAND have all dropped to the threshold levels set by ZERO SPD. LEVEL and ZERO IAD LEVEL.

This is similar to Standstill logic (it stops making current but the contactor stays energised) except that the speed loop remains enabled and this will cause the current loop to unquench very quickly.

**MMI Menu Map**

- 1 SETUP PARAMETERS
- 2 SPEED LOOP
- 3 ADVANCED
  - >> ADAPTION
  - I GAIN IN RAMP
  - >> ZERO SPD. QUENCH

**MMI Menu Map**

- 1 SETUP PARAMETERS
- 2 SPEED LOOP
- 3 ADVANCED
- 4 ADAPTION
  - MODE
  - SPD BRK 1 (LOW)
  - SPD BRK 2 (HIGH)
  - PROP. GAIN
  - INT.TIME. CONST

**MMI Menu Map**

- 1 SETUP PARAMETERS
- 2 SPEED LOOP
- 3 ADVANCED
- 4 ZERO SPD. QUENCH
  - ZERO SPD. LEVEL
  - ZERO IAD LEVEL

**SPEED LOOP**

Parameter	Tag	Range
<b>SPD PROP GAIN</b>	<b>14</b>	<b>0.00 to 200.00</b>
Speed loop PI proportional gain adjustment.		
<b>SPD INT TIME</b>	<b>13</b>	<b>0.001 to 30.000 s</b>
Speed loop PI integral gain adjustment.		
<b>INT. DEFEAT</b>	<b>202</b>	<b>OFF / ON</b>
When ON it inhibits the integral part of the speed loop PI control to give proportional only control.		
<b>SPEED FBK FILTER</b> (SPD.FBK.FILTER)	<b>547</b>	<b>0.000 to 1.000</b>
A simple filter function that is applied to speed feedback to reduce ripple caused by low line count encoders and noisy tachos. A value of 0 disables the filter action ,and 1.00 is the maximum value. A typical value would be between 0.5 and 0.75. INCREASING THE FILTER VALUE MAY MAKE THE SPEED LOOP UNSTABLE. The filter time constant $\tau$ in milliseconds can be calculated from the following equation:		
$\tau = \frac{3.3}{\text{Log}_e\left(\frac{1}{\alpha}\right)}$		
Where $\alpha$ is the value of SPD FBK FILTER. A value of 0.5 equates to a filter time of 4.8ms, 0.8 to 14.7ms, and 0.9 to 31.2ms.		
<b>SETPOINT 1</b>	<b>289</b>	<b>-105.00 to 105.00 %</b>
Speed Setpoint 1 (Default Setpoint Sum 1 O/P).		
<b>SIGN 2 (A3)</b>	<b>9</b>	<b>NEGATIVE / POSITIVE</b>
Speed Setpoint 2 Sign.		

<b>SPEED LOOP</b>		
<b>Parameter</b>	<b>Tag</b>	<b>Range</b>
<b>RATIO 2 (A3)</b> Speed Setpoint 2 Ratio.	<b>7</b>	<b>-3.0000 to 3.0000</b>
<b>SETPOINT 3</b> Speed Setpoint 3 (Default Ramp O/P).	<b>291</b>	<b>-105.00 to 105.00 %</b>
<b>SETPOINT 4</b> Speed Setpoint 4 (Default 5703 I/P).	<b>41</b>	<b>-105.00 to 105.00 %</b>
<b>MAX DEMAND</b> Sets the maximum input to the speed loop. It is clamped at 105% to allow for overshoot in the external loops.	<b>357</b>	<b>0.00 to 105.00 %</b>
<b>MIN DEMAND</b> Sets the minimum input to the speed loop.	<b>358</b>	<b>-105.00 to 105.00 %</b>
<b>PRESET TORQUE</b> The PRESET TORQUE is pre-loaded into the speed loop integral store as the speed loop in enabled. This is scaled by PRESET T SCALE. This may be used to pre-load the output of the speed loop in elevator/hoist applications to prevent the load from falling back when the brake is released. PRESET T SCALE may be used in situations where the load may vary.	<b>595</b>	<b>-200.00 to 200.00 %</b>
<b>PRESET T SCALE</b> Scaler for PRESET TORQUE.	<b>604</b>	<b>-200.00 to 200.00 %</b>
<b>MODE</b> Selects the speed breakpoint input signal. 0 : DISABLED 1 : SPD FBK DEP      Speed Feedback Dependent 2 : SPD ERR DEP      Speed Error Dependent 3 : CUR DMD DEP      Current Demand Dependent	<b>268</b>	<b>See below</b>
<b>SPD BRK 1 (LOW)</b> Speed breakpoint 1 to start gain profiling.	<b>269</b>	<b>0.00 to 100.00 %</b>
<b>SPD BRK 2 (HIGH)</b> Speed breakpoint 2 to stop gain profiling.	<b>270</b>	<b>0.00 to 100.00 %</b>

<b>SPEED LOOP</b>		
<b>Parameter</b>	<b>Tag</b>	<b>Range</b>
<b>PROP. GAIN</b>	<b>271</b>	<b>0.00 to 200.00</b>
Proportional gain used below SPD BRK 1 (LOW)		
<b>INT. TIME CONST.</b>	<b>272</b>	<b>0.001 to 30.000 s</b>
Integral time constant used below SPD BRK 1 (LOW)		
<b>I GAIN IN RAMP</b>	<b>274</b>	<b>0.0000 to 2.0000</b>
This scales the integral gain when the drive is ramping. When RAMPING (Tag No. 113) is TRUE, the integral gain from ADAPTION is switched through the I GAIN IN RAMP scaler. This can be used to help prevent integral wind-up while the drive is ramping (particularly high inertia loads).		
<b>ZERO SPD. LEVEL</b>	<b>284</b>	<b>0.00 to 200.00 %</b>
Sets the threshold of SPEED DEMAND and SPEED FEEDBACK for suspending the current output.		
<b>ZERO IAD LEVEL</b>	<b>285</b>	<b>0.00 to 200.00 %</b>
Sets the current demand threshold for suspending the current output.		
<b>SPEED ERROR FILTERED</b>	<b>297</b>	<b>—.xx %</b>
<i>Refer to Chapter 6: "The Keypad" - The Keypad Menus (DIAGNOSTICS).</i>		
<b>SPEED LOOP O/P</b>	<b>549</b>	<b>—.xx %</b>
<i>Refer to Chapter 6: "The Keypad" - The Keypad Menus (DIAGNOSTICS).</i>		
<b>SPEED DEMAND</b>	<b>89</b>	<b>—.xx %</b>
<i>Refer to Chapter 6: "The Keypad" - The Keypad Menus (DIAGNOSTICS).</i>		
<b>UNFIL.SP.D.FBK</b>	<b>62</b>	<b>—.xx %</b>
<i>Refer to Chapter 6: "The Keypad" - The Keypad Menus (DIAGNOSTICS).</i>		
<b>SPEED SETPOINT</b>	<b>63</b>	<b>—.xx %</b>
<i>Refer to Chapter 6: "The Keypad" - The Keypad Menus (DIAGNOSTICS).</i>		
<b>UNFIL.SP.D.ERROR</b>	<b>64</b>	<b>—.xx %</b>
<i>Refer to Chapter 6: "The Keypad" - The Keypad Menus (DIAGNOSTICS).</i>		
<b>SETPOINT 2 (A3)</b>	<b>290</b>	<b>—.xx %</b>
Speed Setpoint 2 - Fixed (non-configurable) setpoint scanned synchronously with the current loop		

**SPEED LOOP**

Parameter	Tag	Range
<b>SPEED FBK SELECT</b>	<b>47</b>	<b>See below</b>
<p>Determines the source of the speed feedback signal. The default, ARM VOLTS FBK, uses internal circuitry to derive the speed feedback. The other selections require the appropriate external device to provide the feedback signal.</p> <p>0 : ARM VOLTS FBK            1 : ANALOG TACH            2 : ENCODER            3 : ENCODER/ANALOG - for Parker SSD Drives use</p>		

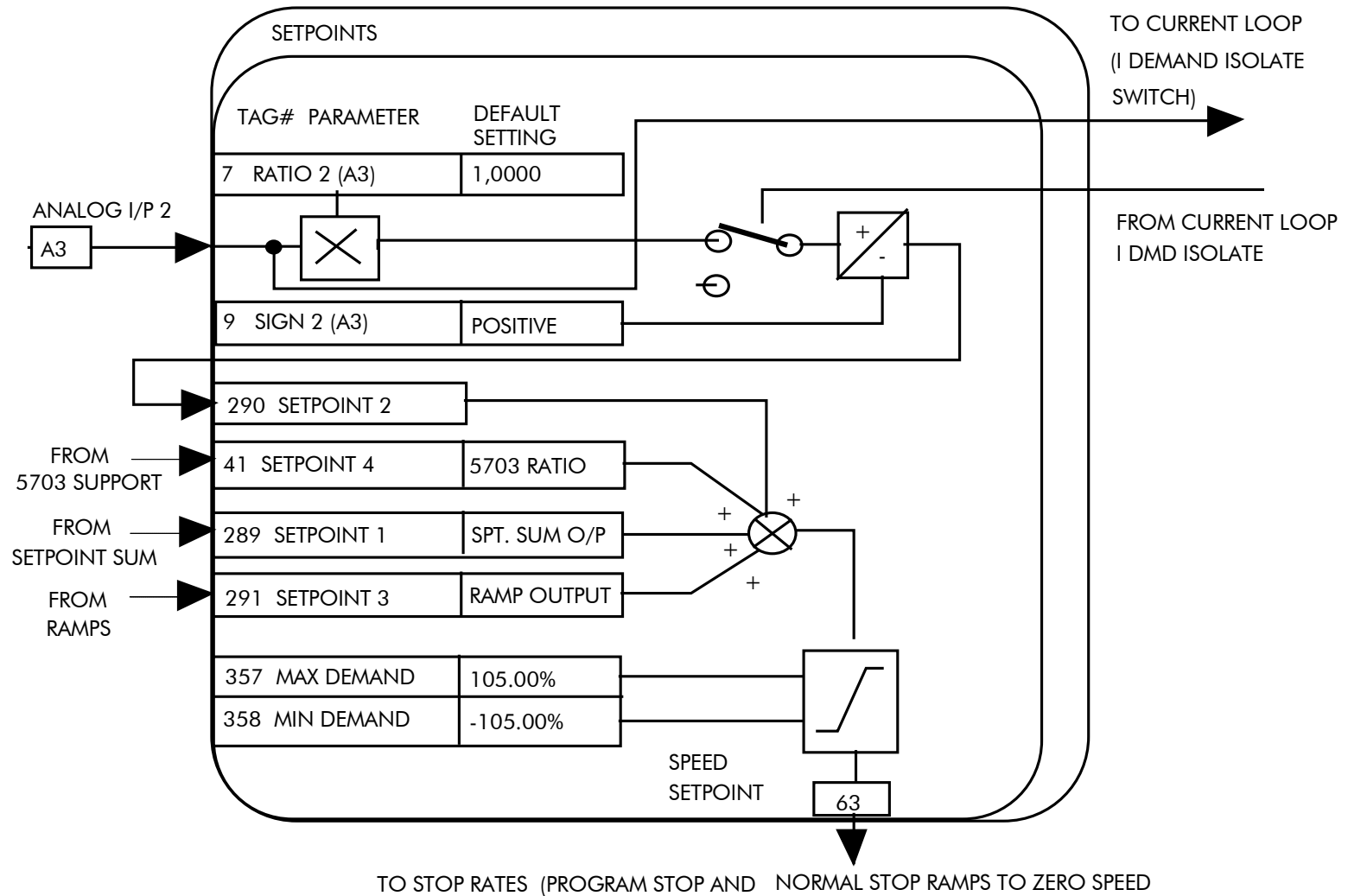
**Functional Description****Speed Loop PI with Current Demand Isolate**

The speed loop output is still valid (active) with the I DMD. ISOLATE parameter enabled.

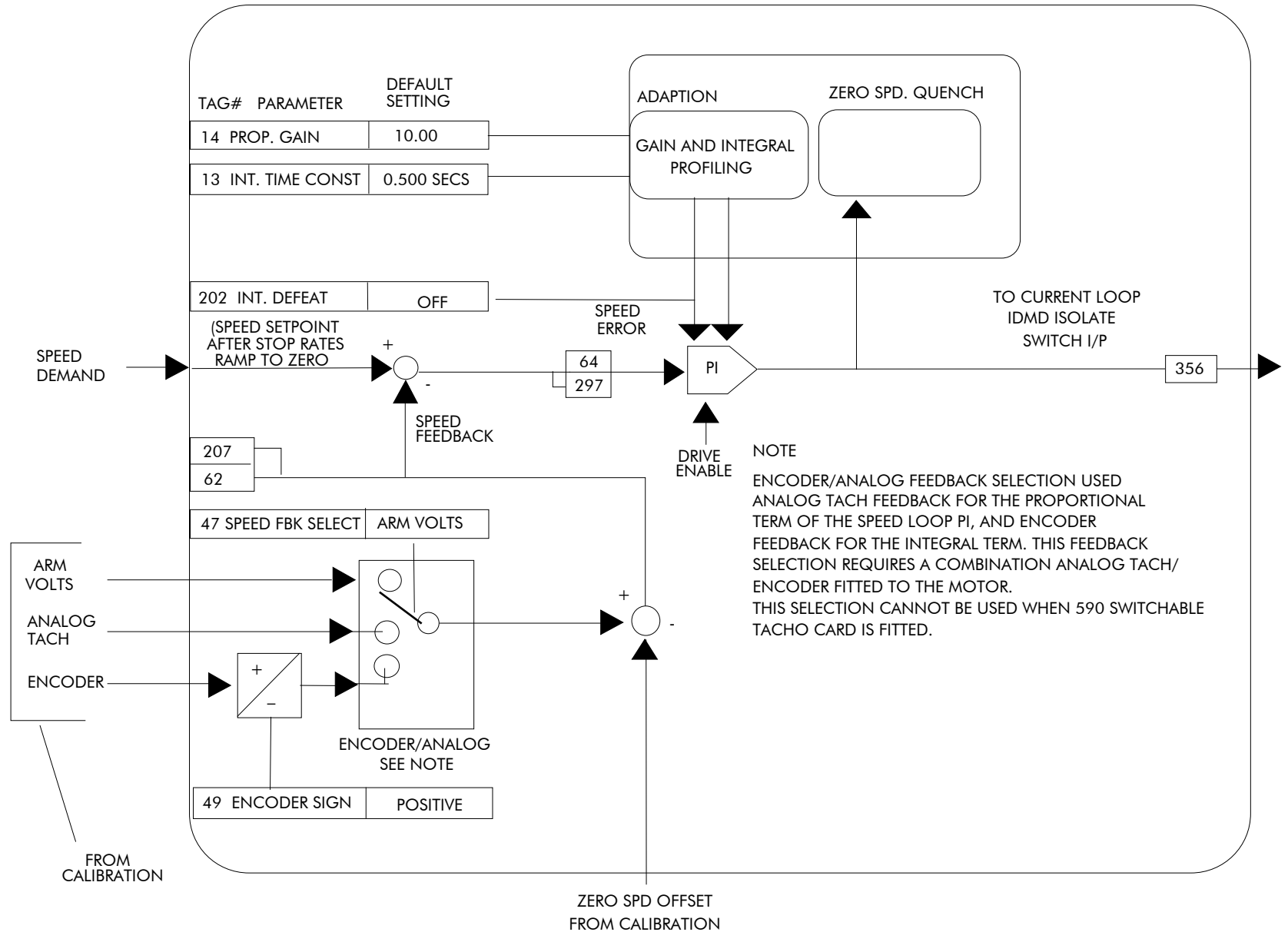
- NOTE**
- 1 **The speed loop is reset by unquenching the speed loop/current loop.**
  - 2 **I DMD. ISOLATE is overridden by Program Stop (B8) or Normal Stop (C3).**
  - 3 **The speed loop PI holds the integral term as soon as the PI output reaches current limit. This is true even in Current Demand Isolate mode where it may interfere depending on the way the speed PI is used. This feature is currently not suppressible.**

### 105% Speed Demands

The speed demand clamping allows the speed setpoint to reach 105%. This applies only to the final summing junction immediately before the speed loop and also to the Setpoint Sum 1 output. Individual speed setpoints are still clamped to 100%.

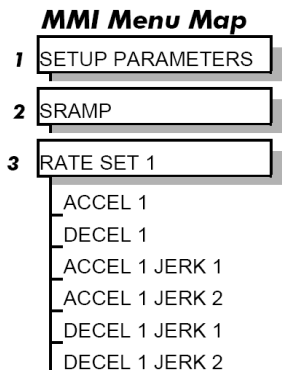
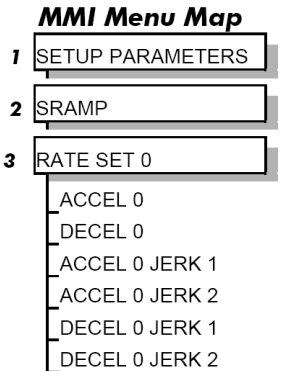
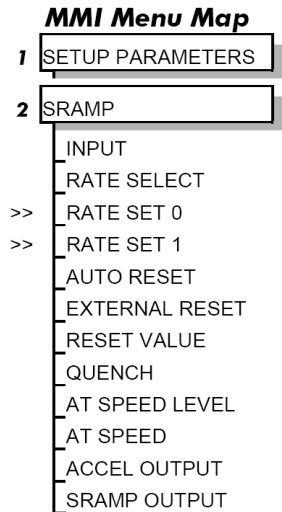
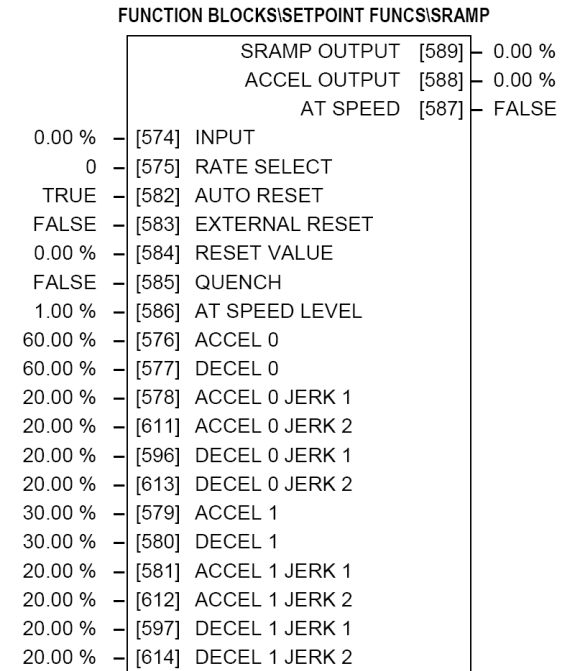


SPEED LOOP



# SRAMP

This function block limits the rate of change of an input by limiting the acceleration and the jerk (rate of change of acceleration).



SRAMP		
Parameter	Tag	Range
<b>INPUT</b>	<b>574</b>	<b>-100.00 to 100.00 %</b>
Input value.		
<b>RATE SELECT</b>	<b>575</b>	<b>0 to 1</b>
Selects between one of two parameter sets. This allows you to have two operating modes (RATE SET 0 or RATE SET 1) with independent ramp parameters.		
<b>AUTO RESET</b>	<b>582</b>	<b>FALSE / TRUE</b>
The ramp is reset automatically when the drive is enabled if set to TRUE.		
<b>EXTERNAL RESET</b>	<b>583</b>	<b>FALSE / TRUE</b>
Resets the ramp output.		



<b>SRAMP</b>		
<b>Parameter</b>	<b>Tag</b>	<b>Range</b>
<b>RESET VALUE</b>	<b>584</b>	<b>-100.00 to 100.00 %</b>
The output value while RESET is TRUE also used as initial value on start up. If this is linked to speed feedback, the initial ramp output will be set to the current value of speed feedback.		
<b>QUENCH</b>	<b>585</b>	<b>FALSE / TRUE</b>
If TRUE forces the ramp input to zero.		
<b>AT SPEED LEVEL</b>	<b>586</b>	<b>0.00 to 100.00 %</b>
Threshold for AT SPEED diagnostic output.		
<b>ACCEL 0</b>	<b>576</b>	<b>0.00 to 100.00 %</b>
Acceleration rate, in units of percent per second <sup>2</sup> . i.e. 75.00 % means that the maximum acceleration will be 75.00% per second <sup>2</sup> if the full speed of the machine is 1.25ms then the acceleration will be $1.25 * 75.0\% = 0.9375\text{ms}^2$ .		
<b>DECEL 0</b>	<b>577</b>	<b>0.00 to 100.00 %</b>
Deceleration rate, only active if SYMMETRIC = TRUE.		
<b>ACCEL 0 JERK 1</b>	<b>578</b>	<b>0.00 to 100.00 %</b>
Rate of change of acceleration, in units of percent per second <sup>3</sup> . For example: 75.00 % means that the maximum acceleration will be 50.00% per second <sup>3</sup> if the full speed of the machine is 1.25ms then the acceleration will be $1.25 * 50.0\% = 0.625\text{ms}^3$ . If SYMMETRIC = TRUE then this value will be used for each of the four segments of the profile. If SYMMETRIC = TRUE then this value will be used only for the first acceleration segment.		
<b>ACCEL 0 JERK 2</b>	<b>611</b>	<b>0.00 to 100.00 %</b>
Rate of change of acceleration in units of percent per second <sup>3</sup> for segment 2. Only applicable if SYMMETRIC = FALSE.		
<b>DECEL 0 JERK 1</b>	<b>596</b>	<b>0.00 to 100.00 %</b>
Rate of change of acceleration in units of percent per second <sup>3</sup> for segment 3. Only applicable if SYMMETRIC = FALSE.		
<b>DECEL 0 JERK 2</b>	<b>613</b>	<b>0.00 to 100.00 %</b>
Rate of change of acceleration in units of percent per second <sup>3</sup> for segment 4. Only applicable if SYMMETRIC = FALSE.		
<b>ACCEL 1</b>	<b>579</b>	<b>0.00 to 100.00 %</b>
Refer to ACCEL 0.		
<b>DECEL 1</b>	<b>580</b>	<b>0.00 to 100.00 %</b>
Refer to DECEL 0.		
<b>ACCEL 1 JERK 1</b>	<b>581</b>	<b>0.00 to 100.00 %</b>
Refer to ACCEL 0 JERK 1.		

**SRAMP**

Parameter	Tag	Range
<b>ACCEL 1 JERK 2</b> Refer to ACCEL 0 JERK 2.	<b>612</b>	<b>0.00 to 100.00 %</b>
<b>DECEL 1 JERK 1</b> Refer to DECEL 0 JERK 1.	<b>597</b>	<b>0.00 to 100.00 %</b>
<b>DECEL 1 JERK 2</b> Refer to DECEL 0 JERK 2.	<b>614</b>	<b>0.00 to 100.00 %</b>
<b>SRAMP OUTPUT</b> Diagnostic, ramp output.	<b>589</b>	<b>— .xx %</b>
<b>ACCEL OUTPUT</b> Acceleration diagnostic.	<b>588</b>	<b>— .xx %</b>
<b>AT SPEED</b> Diagnostic output indicating the Abs (input - output) is less than AT SPEED LEVEL.	<b>587</b>	<b>FALSE / TRUE</b>

**Useful Equations**

**NOTE**

These only hold true if Jerk = Jerk2 for acceleration or Jerk 3 = Jerk 4 for deceleration.

V is the maximum speed the drive must reach.

In % / sec

A is the maximum allowable acceleration in %/sec<sup>2</sup>

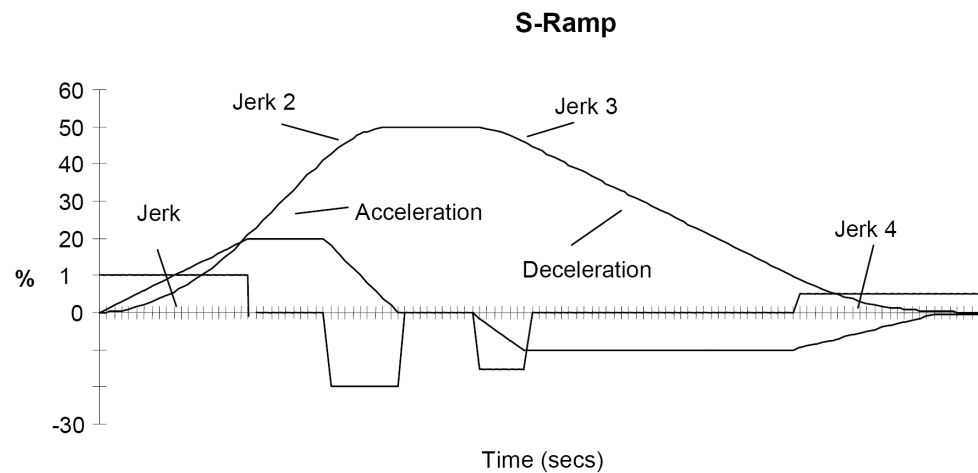
J is the maximum allowable value for jerk, in %/sec<sup>3</sup>

The time needed to stop or accelerate is:

$$t = \frac{V}{A} + \frac{A}{J} \text{ [Seconds]}$$

as the speed is symmetrical the average speed is V/2, therefore the stopping / acceleration distance can be calculated.

$$s = \frac{V}{2} \left( \frac{V}{A} + \frac{A}{J} \right) \text{ [Meters]}$$



**Example acceleration graph for a velocity 60 %/s maximum Acceleration of 20 %/s<sup>2</sup> and a jerk of 10 %/s<sup>3</sup>**

**MMI Menu Map**

- 1 SETUP PARAMETERS
- 2 STANDSTILL
  - STANDSTILL LOGIC
  - ZERO THRESHOLD

**MMI Menu Map**

- 1 FUNCTION BLOCKS
- 2 SEQ & REF
- 3 STANDSTILL
  - ZERO SETPOINT

**MMI Menu Map**

- 1 DIAGNOSTICS
  - AT ZERO SPEED
  - AT ZERO SETPOINT
  - AT STANDSTILL

## STANDSTILL

Set a **ZERO THRESHOLD** defining when the speed setpoint is at zero to inhibit motor rotation.

The inputs to this block are SPEED FEEDBACK from the SPEED LOOP function block and SPEED SETPOINT from setpoints.

The outputs are AT ZERO SPEED, AT STANDSTILL, and AT ZERO SETPOINT. AT ZERO SPEED is connected to DIGOUT 1 (B5) in the default configuration. A "not at standstill" signal is sent to the drive enable logic.

When SPEED FEEDBACK is less than ZERO THRESHOLD, AT ZERO SPEED is TRUE.

When SPEED SETPOINT is less than ZERO THRESHOLD, AT ZERO SETPOINT is TRUE.

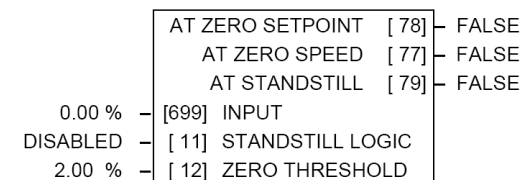
When both AT ZERO SPEED and AT ZERO SETPOINT are TRUE, AT STANDSTILL is TRUE signalling the motor has stopped.

If AT STANDSTILL is TRUE and STANDSTILL LOGIC is ENABLED, then the speed and current loops are quenched. The SCR (Silicon Controlled Rectifier)/thyristor firing circuits are disabled, the main contactor remains energised and the RUN LED stays on when the drive is at standstill. The drive remains in this state until standstill drops out. That is, when the speed setpoint or speed feedback rise above the zero threshold.

STANDSTILL LOGIC is useful in maintaining absolute zero speed and aids in preventing gearbox wear due to "chattering".

However, it can cause problems in web handling applications using tension feedback: at zero speed, the SCR/thyristors turn off allowing the web tension to pull the driven roll in reverse. When the drive no longer senses it is at zero speed, the SCR/thyristors turn back on causing the motor to move forward and regulate tension. An oscillation condition can result as the drives SCR/thyristors turn on and off trying to maintain a fixed position.

FUNCTION BLOCKS\SEQ & REF\STANDSTILL

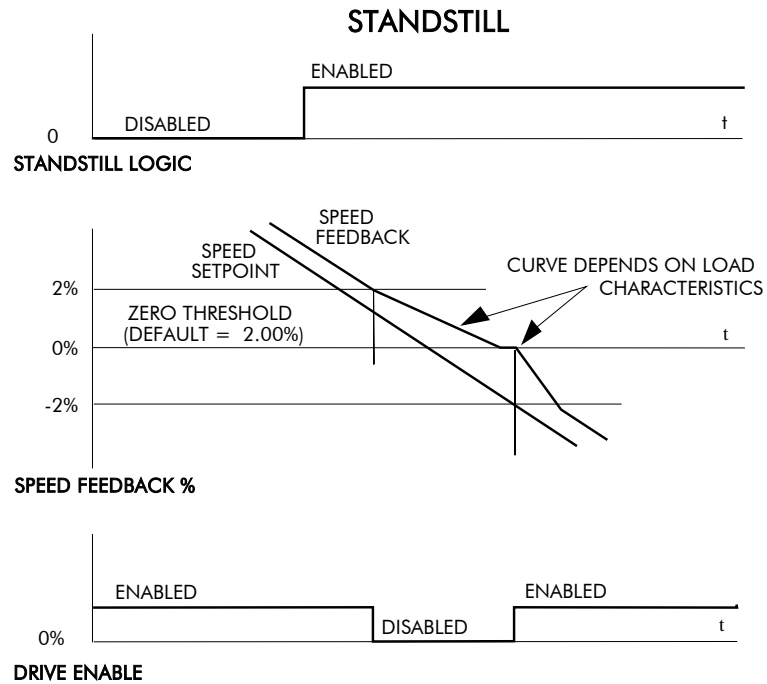


### STANDSTILL

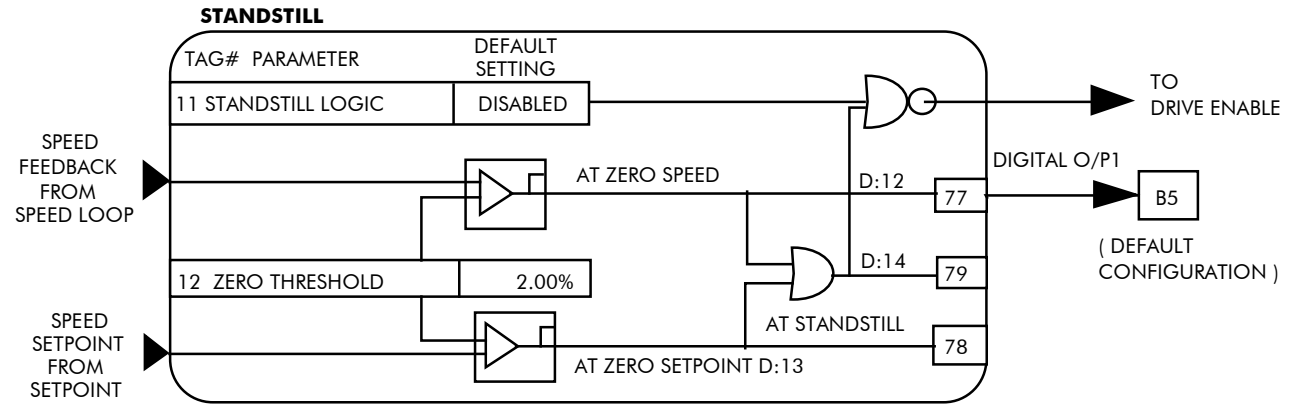
Parameter	Tag	Range
ZERO SETPOINT	699	-300.00 to 300.00 %
The input to the standstill function. By default this is connected to the speed demand parameter from the speed loop function block.		
STANDSTILL LOGIC	11	DISABLED / ENABLED
If ENABLED, the Drive is quenched (although the contactor remains in) when the Speed Feedback and Speed Setpoint values are less than ZERO THRESHOLD.		
ZERO THRESHOLD	12	0.00 to 100.00 %
Threshold level which defines zero setpoint and zero speed diagnostic outputs and also controls the zero speed relay output.		
AT ZERO SETPOINT	78	FALSE / TRUE
Logic output, TRUE when INPUT is below ZERO THRESHOLD. There is hysteresis of 0.5% on this test.		
AT ZERO SPEED	77	FALSE / TRUE

## STANDSTILL

Parameter	Tag	Range
Logic output, TRUE when speed feedback is below ZERO THRESHOLD. There is hysteresis of 0.5% on this test. The speed feedback parameter is internally connected to the PERCENT RPM parameter in the FEEDBACKS block.		
<b>AT STANDSTILL</b>	<b>79</b>	<b>FALSE / TRUE</b>
Logic output that is TRUE when standstill is detected.		



# D-128 Programming



**MMI Menu Map**

- 1 SETUP PARAMETERS
- 2 STOP RATES
  - STOP TIME
  - STOP LIMIT
  - CONTACTOR DELAY
  - CURR DECAY RATE
  - PROG STOP TIME
  - PROG STOP LIMIT
  - PROG STOP I LIM
  - STOP ZERO SPEED

## STOP RATES

These parameters are used by a regenerative drive when stopping with Normal Stop or Program Stop.

The stopping methods of the drive are described in more detail in Chapter 4: “Operating the Drive” - Starting and Stopping Methods.

The internal inputs to this block are SPEED SETPOINT and SPEED FEEDBACK from the SPEED LOOP function block, the Run signal from terminal C3, and PROGRAM STOP from terminal B8.

The internal outputs are SPEED DEMAND to the speed loop, PROG STOP I LIM to the current loop, and signals to the coast stop and drive enable logic.

FUNCTION BLOCKS	SEQ & REFI	STOP RATES
10.0 s	[ 27]	STOP TIME
60.0 s	[217]	STOP LIMIT
1.0 s	[302]	CONTACTOR DELAY
0.00	[594]	CURR DECAY RATE
0.1 s	[ 26]	PROG STOP TIME
60.0 s	[216]	PROG STOP LIMIT
100.00 %	[ 91]	PROG STOP I LIM
2.00 %	[ 29]	STOP ZERO SPEED

### Normal Stop

A Normal Stop occurs when the Run signal is removed from terminal C3. It ramps the speed demand to zero at a rate set by STOP TIME.

- Non-regenerative drives can stop no faster than the coast stop rate.
- Regenerative drives use STOP TIME to set the duration of the stop.

After the stop, the contactor de-energises and the drive disables.

The STOP LIMIT timer starts when C3 goes to 0V (the Run signal is removed). If the drive speed has not reached STOP ZERO SPEED within the STOP LIMIT time, the contactor de-energises and the drive disables.

During Normal Stops, after the motor reaches zero speed, CONTACTOR DELAY delays the de-energising of the contactor. When STOP ZERO SPEED is set above 0.25% and the CURRENT DECAY RATE is not zero, the drive disables during the contactor delay. Otherwise the drive disables after the contactor delay. This is useful when using the Jog function to prevent multiple operations of the contactor. CONTACTOR DELAY is overridden when terminal C5 (Enable Input) is at 0V.

### Program Stop

PROGRAM STOP provides a controlled fast stop for regenerative drives. The stop time is set by PROG STOP TIME. This timer starts once terminal B8 (Program Stop) goes to 0V. When the drive reaches STOP ZERO SPEED, the contactor de-energises and the drive disables. PROG STOP LIMIT sets the maximum time the Program Stop can take before the contactor de-energises and the drive disables.

PROG STOP I LIM sets the current limit in the current loop during a Program Stop. Other current limits can override it.

<b>STOP RATES</b>		
<b>Parameter</b>	<b>Tag</b>	<b>Range</b>
<b>STOP TIME</b>	<b>27</b>	<b>0.1 to 600.0 s</b>
Time to reach zero speed from 100% set speed in normal stop mode (terminal C3 = 0V).		
<b>STOP LIMIT</b>	<b>217</b>	<b>0.0 to 600.0 s</b>
The maximum time a controlled stop can take in a Normal Stop (regenerative braking) before the drive will coast to stop. The timer is triggered when terminal C3 = 0V.		
<b>CONTACTOR DELAY</b>	<b>302</b>	<b>0.1 to 600.0 s</b>
This defines the time the contactor stays energised for after the STOP ZERO SPEED limit is reached. <b>Maintain zero speed during contactor delay.</b>		
<b>CURR DECAY RATE</b>	<b>594</b>	<b>0.00 to 200.00 %/s</b>
This is the rate at which the current is quenched when the current loop is disabled. A value of 100% will ramp the current from 100% to 0% in 1s. A value of 50% will ramp the current from 100% to 0% in 2s.		
<b>PROG STOP TIME</b>	<b>26</b>	<b>0.1 to 600.0 s</b>
Time to reach zero speed from 100% set speed in Program Stop mode (B8 = 0V).		
<b>PROG STOP LIMIT</b>	<b>216</b>	<b>0.0 to 600.0 s</b>
The maximum time a Program Stop (regenerative braking) can take before the contactor is de-energised and the drive is disabled. The timer is triggered when terminal B8 = 0V.		
<b>PROG STOP I LIM</b>	<b>91</b>	<b>0.00 to 200.00 %</b>
Main current limit level (assuming current limit not overridden by I Profile or Inverse Time limits) when performing a Program Stop.		
<b>STOP ZERO SPEED</b>	<b>29</b>	<b>0.00 to 100.00 %</b>
The threshold at which the CONTACTOR DELAY timer starts in Program Stop and Normal Stop modes. See also CONTACTOR DELAY above.		

## Functional Description

### Stop Hierarchy

#### Coast Stop - Terminal B9

- Disables the drive and opens the contactor via the pilot output

#### Enable - Terminal C5

- Suspends and resets the Control Loops

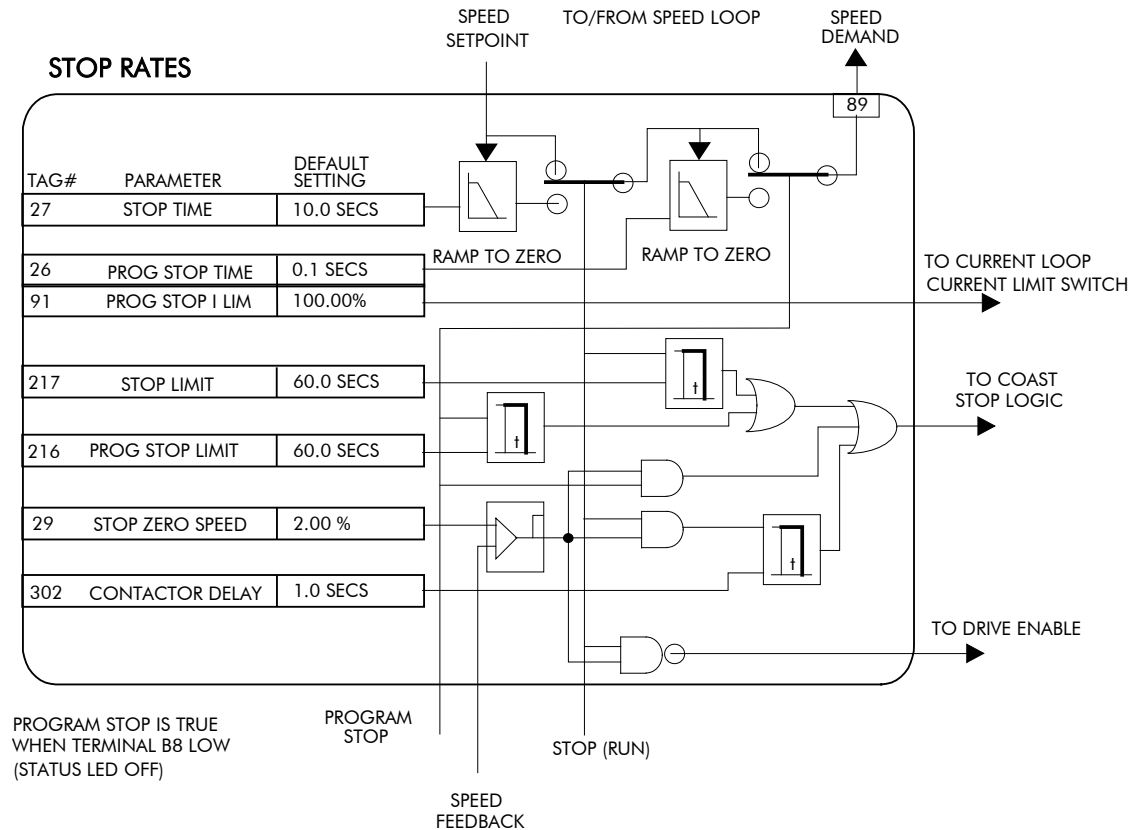
#### Program Stop - Terminal B8

- Independent ramp time
- Stop Timer
- Independent Current Limit that may be higher than normal Current Limit
- Independent zero speed

#### Normal Run/Stop - Terminal C3

- Independent ramp time
- Contactor Delay

The Drive's reaction to commands is defined by a state machine. This determines which commands provide the demanded action, and in which sequence. Consequently, COAST STOP and PROGRAM STOP must be FALSE, i.e. the drive is not in Coast or Program mode, before a Run signal is applied otherwise the controller assumes a Stop mode and remains disabled. Refer to Chapter 4: "Operating the Drive" - Stopping Methods for descriptions of Coast Stop and Program Stop.





## TEC OPTION

### MMI Menu Map

- 1 SERIAL LINKS
- 2 TEC OPTION
  - TEC OPTION TYPE
  - TEC OPTION IN 1
  - TEC OPTION IN 2
  - TEC OPTION IN 3
  - TEC OPTION IN 4
  - TEC OPTION IN 5
  - TEC OPTION FAULT
  - TEC OPTION VER
  - TEC OPTION OUT 1
  - TEC OPTION OUT 2

This function block is used to configure the inputs and outputs of the various Technology Options that can be fitted.

The Technology Option provides a communications interface for external control of the Drive.

Refer to the appropriate Technology Option Technical Manual supplied with the option for further details.

### FUNCTION BLOCKS\COMMUNICATIONS\TEC OPTION

	TEC OPTION FAULT	[506]	NONE
	TEC OPTION VER	[507]	0x0000
	TEC OPTION OUT 1	[508]	0
	TEC OPTION OUT 2	[509]	0
NONE	[500]	TEC OPTION TYPE	
0	[501]	TEC OPTION IN 1	
0	[502]	TEC OPTION IN 2	
0	[503]	TEC OPTION IN 3	
0	[504]	TEC OPTION IN 4	
0	[505]	TEC OPTION IN 5	

## TEC OPTION

Parameter	Tag	Range
<b>TEC OPTION TYPE</b>	<b>500</b>	<b>See below</b>
Selects the type of Technology Option.		
0 : NONE	10 : TYPE 10	
1 : RS485	11 : TYPE 11	
2 : PROFIBUS	12 : TYPE 12	
3 : LINK	13 : TYPE 13	
4 : DEVICE NET	14 : TYPE 14	
5 : CAN OPEN	15 : TYPE 15	
6 : LONWORKS		
7 : CONTROLNET		
8 : MODBUS PLUS		
9 : ETHERNET		

<b>TEC OPTION IN 1 to TEC OPTION IN 5</b>	<b>501, 502, 503, 504, 505</b>	<b>-32768 to 32767</b>
The use of these input parameters depends upon the type of Technology Option fitted. Refer to the Technology Option Technical Manual.		

**TEC OPTION**

Parameter	Tag	Range
<b>TEC OPTION FAULT</b>	<b>506</b>	<b>See below</b>
The fault state of the Technology Option.		
0 : NONE	no faults	
1 : PARAMETER	parameter out-of-range	
2 : TYPE MISMATCH	TYPE parameter mismatch	
3 : SELF TEST	hardware fault - internal	
4 : HARDWARE	hardware fault - external	
5 : MISSING	no option fitted	
If the VERSION NUMBER error message is displayed, the Technology Option is using software that doesn't fully support the drive; refer to Parker SSD Drives.		
<b>TEC OPTION VER</b>	<b>507</b>	<b>0x0000 to 0xFFFF</b>
The version of the Technology Option. If no option is fitted then the version is reset to zero.		
<b>TEC OPTION OUT 1 to TEC OPTION OUT 2</b>	<b>508, 509</b>	<b>—</b>
The use of these output parameters depends upon the type of Technology Option fitted. Refer to the Technology Option Technical Manual.		

## MMI Menu Map

- 1 SETUP PARAMETERS
- 2 SPECIAL BLOCKS
- 3 TORQUE CALC.
  - TORQUE DEMAND
  - TENSION ENABLE
  - OVER WIND

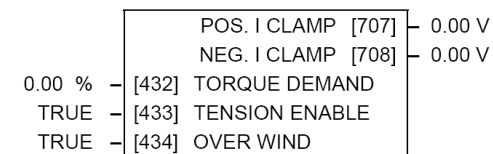
## MMI Menu Map

- 1 SYSTEM
- 2 CONFIGURE I/O
- 3 BLOCK DIAGRAM
  - POS. I CLAMP
  - NEG. I CLAMP

# TORQUE CALC.

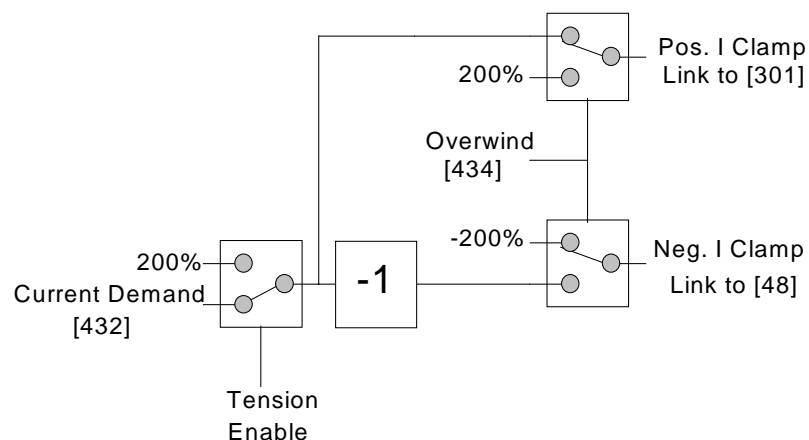
This block switches the drive between Speed and Tension mode. It also switches the current limits as required for over and under winding.

FUNCTION BLOCKSWINDER/TORQUE CALC.



## TORQUE CALC.

Parameter	Tag	Range
<b>TORQUE DEMAND</b>	<b>432</b>	<b>-200.00 to 200.00 %</b>
This is the TORQUE CALC function block input.		
<b>TENSION ENABLE</b>	<b>433</b>	<b>DISABLED / ENABLED</b>
When TENSION ENABLE is ENABLED , the tension demand is set by the TORQUE DEMAND signal , tag 432. When DISABLED, it is set by the default current limit. Switch using a free digital input.		
<b>OVER WIND</b>	<b>434</b>	<b>DISABLED / ENABLED</b>
Reverses the sign of the output clamps for over/under winding. Switch using a free digital input.		
<b>POS. I CLAMP</b>	<b>707</b>	<b>— .xx V</b>
Positive current clamp.		
<b>NEG. I CLAMP</b>	<b>708</b>	<b>— .xx V</b>
Negative current clamp		



# VALUE FUNC

The value function blocks can be configured to perform one of a number of functions upon a fixed number of inputs.

Boolean inputs and outputs are

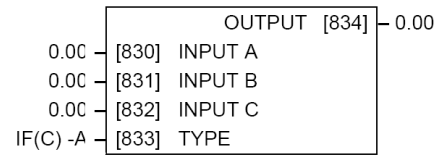
Outputs:  
FALSE = 0.00  
TRUE = 0.01

Inputs:  
 $-0.005 < x < 0.005 = \text{FALSE}$ ,  
Else TRUE

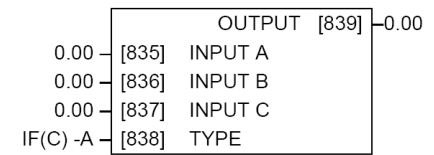
## MMI Menu Map

- 1 FUNCTION BLOCKS
- 2 MISCELLANEOUS
- 3 VALUE FUNC
- 4 VALUE FUNC 1
- 4 VALUE FUNC 2
- 4 VALUE FUNC 3
- 4 VALUE FUNC 4
- 4 VALUE FUNC 5
- 4 VALUE FUNC 6
- 4 VALUE FUNC 7
- 4 VALUE FUNC 8
- 4 VALUE FUNC 9
- 4 VALUE FUNC 10
- INPUT A
- INPUT B
- INPUT C
- TYPE
- OUTPUT

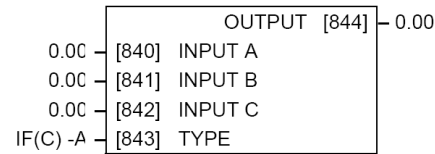
FUNCTION BLOCKS MISCELLANEOUS VALUE FUNC VALUE FUNC 1



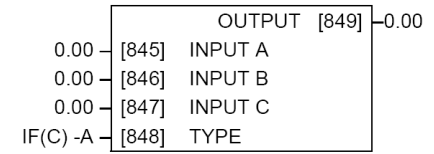
FUNCTION BLOCKS MISCELLANEOUS VALUE FUNC VALUE FUNC 2



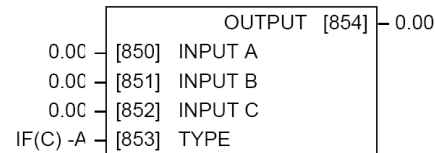
FUNCTION BLOCKS MISCELLANEOUS VALUE FUNC VALUE FUNC 3



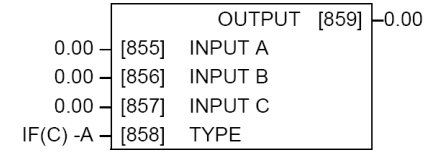
FUNCTION BLOCKS MISCELLANEOUS VALUE FUNC VALUE FUNC 4



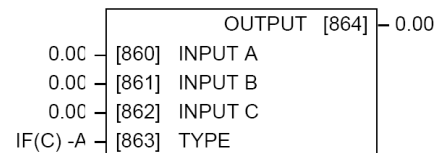
FUNCTION BLOCKS MISCELLANEOUS VALUE FUNC VALUE FUNC 5



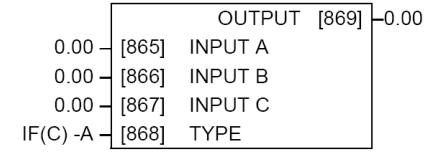
FUNCTION BLOCKS MISCELLANEOUS VALUE FUNC VALUE FUNC 6



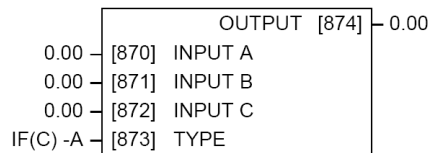
FUNCTION BLOCKS MISCELLANEOUS VALUE FUNC VALUE FUNC 7



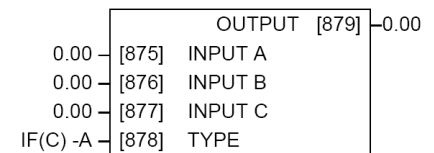
FUNCTION BLOCKS MISCELLANEOUS VALUE FUNC VALUE FUNC 8



FUNCTION BLOCKS MISCELLANEOUS VALUE FUNC VALUE FUNC 9



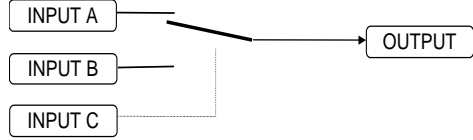
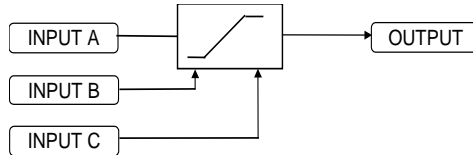
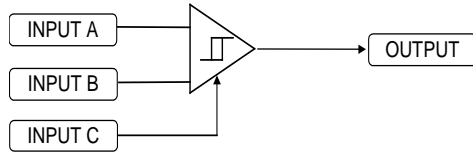
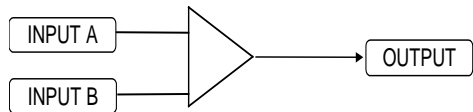
FUNCTION BLOCKS MISCELLANEOUS VALUE FUNC VALUE FUNC 10



VALUE FUNCTION		
Parameter	Tag	Range
<b>INPUT A</b>	<b>830, 835, 840, 845, 850, 855, 860, 865, 870, 875</b>	<b>-32768 to 32768</b>
General purpose input.		
<b>INPUT B</b>	<b>831, 836, 841, 846, 851, 856, 861, 866, 871, 876</b>	<b>-32768 to 32768</b>
General purpose input.		
<b>INPUT C</b>	<b>832, 837, 842, 847, 852, 857, 862, 867, 872, 877</b>	<b>-32768 to 32768</b>
General purpose input.		
<b>TYPE</b>	<b>833, 838, 843, 848, 853, 858, 863, 868, 873, 878</b>	<b>See below</b>
The operation to be performed on the three inputs to produce the output value.		
0: IF(C) -A	16: TIMER	31: PROFILE $x^3$
1: ABS(A+B+C)	17: MINIMUM PULSE	32: PROFILE $x^4$
2: SWITCH(A,B)	18: PULSE TRAIN	33: ON A>B, OFF A<C
3: (A*B)/C	19: WINDOW	34: (A+B) CLAMPED C
4: A+B+C	20: UP/DWN COUNTER	35: (A-B) CLAMPED C
5: A-B-C	21: (A*B)/C ROUND	36: (A*B) CLAMPED C
6: B<=A<=C	22: WINDOW NO HYST	37: (A/B) CLAMPED C
7: A>B+/-C	23: WIND A>=B,A<=C	38: A>=B:A, A<=C:0
8: A>=B	24: A<=B	39: (A * B) + C
9: ABS(A)>B+/-C	25: ((A*B)/100)+C	40: A * (B + C)
10: ABS(A)>=B	26: MIN(A,B,C)	41: A * (B - C)
11: A(1+B)	27: MAX(A,B,C)	42: A * (1+B/C)
12: IF(C) HOLD(A)	28: PROFILE SQRT	43: A * (1+(B * C))
13: BINARY DECODE	29: PROFILE LINEAR	44: MONOSTABLE HIGH
14: ON DELAY	30: PROFILE $x^2$	45: MONOSTABLE LOW
15: OFF DELAY		46: FILTER
<b>OUTPUT</b>	<b>834, 839, 844, 849, 854, 859, 864, 869, 874, 879</b>	<b>— .xx</b>
The result of performing the selected operation on the inputs.		

## Functional Description

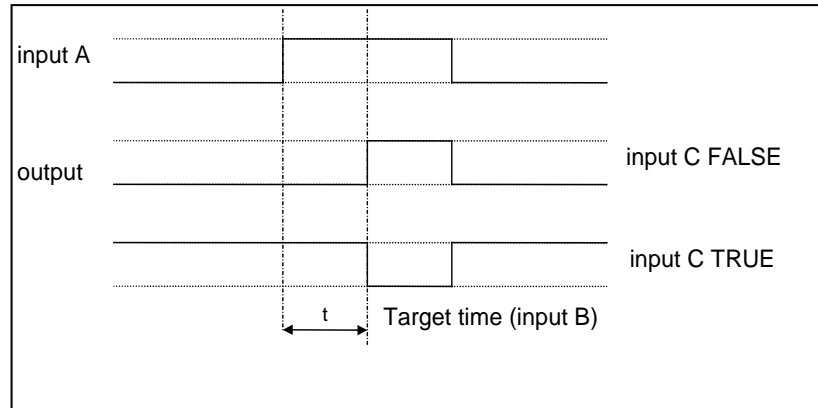
OUTPUT is generated from the inputs according to the operation type selected. The output is always limited to be within the range -32768.00 to +32767.00.

Operation	Description
IF(C) -A	If INPUT C is not zero the OUTPUT is minus INPUT A, otherwise the OUTPUT is the same as INPUT A.
ABS(A+B+C)	The OUTPUT is set to the absolute value of INPUT A + INPUT B + INPUT C.
SWITCH(A,B)	 <p>If INPUT C is zero the OUTPUT is set to INPUT A, otherwise the output is set to INPUT B</p>
(A*B)/C	The OUTPUT is set to (INPUT A * INPUT B) / (INPUT C). The algorithm compensates for the remainder term.
A+B+C	The OUTPUT is set to (INPUT A + INPUT B + INPUT C).
A-B-C	The OUTPUT is set to (INPUT A - INPUT B - INPUT C).
B <= A <= C	 <p>The OUTPUT is set to the value of INPUT A, limited to between a maximum value of INPUT C and a minimum value of INPUT B. If INPUT B is greater than INPUT C the output is undefined.</p>
A > B +/- C	 <p>The OUTPUT is TRUE if INPUT A is greater than INPUT B + INPUT C. The OUTPUT is FALSE if INPUT A is less than INPUT B - INPUT C.</p> <p>Otherwise the OUTPUT is unchanged. In this way the block acts as a simple comparator with a comparison level of INPUT B and a hysteresis band equal to +/- INPUT C.</p>
A >= B	 <p>The OUTPUT is TRUE if INPUT A is greater than or equal to INPUT B, otherwise the OUTPUT is FALSE.</p>

Operation	Description																																				
$ABS(A) > ABS(B) \pm C$	<div style="display: flex; align-items: center;"> <div style="margin-right: 20px;"> </div> <div> <p>The OUTPUT is TRUE if the magnitude of INPUT A is greater than or equal to the magnitude of INPUT B - INPUT C.</p> <p>The OUTPUT is FALSE if the magnitude of INPUT A is less than the magnitude of INPUT B - INPUT C. Otherwise the OUTPUT is unchanged. In this way the block acts as a magnitude comparator with a comparison level of INPUT B and a hysteresis band equal to +/- INPUT C.</p> </div> </div>																																				
$ABS(A) > = ABS(B)$	<div style="display: flex; align-items: center;"> <div style="margin-right: 20px;"> </div> <div> <p>The OUTPUT is TRUE if the magnitude of INPUT A is greater than or equal to the magnitude of INPUT B, otherwise the OUTPUT is FALSE.</p> </div> </div>																																				
$A(1+B)$	<p>The OUTPUT is set to <math>INPUT A + (INPUT A * INPUT B / 100.00)</math>.</p>																																				
IF(C) HOLD A	<p>If INPUT C is zero, the OUTPUT is set to INPUT A, otherwise the OUTPUT is unchanged.</p> <p>On powering up the drive, the output will be pre-loaded with the last saved value of input B.</p>																																				
BINARY DECODE	<p>The OUTPUT is set according to which of the INPUTs are non-zero.</p> <table border="1" style="margin-left: 40px;"> <thead> <tr> <th>INPUT C</th> <th>INPUT B</th> <th>INPUT A</th> <th>OUTPUT</th> </tr> </thead> <tbody> <tr><td>0</td><td>0</td><td>0</td><td>0.00</td></tr> <tr><td>0</td><td>0</td><td>≠0</td><td>1.00</td></tr> <tr><td>0</td><td>≠0</td><td>0</td><td>2.00</td></tr> <tr><td>0</td><td>≠0</td><td>≠0</td><td>3.00</td></tr> <tr><td>≠0</td><td>0</td><td>0</td><td>4.00</td></tr> <tr><td>≠0</td><td>0</td><td>≠0</td><td>5.00</td></tr> <tr><td>≠0</td><td>≠0</td><td>0</td><td>6.00</td></tr> <tr><td>≠0</td><td>≠0</td><td>≠0</td><td>7.00</td></tr> </tbody> </table> <p>In the above table, ≠0 indicates that the corresponding input is not zero.</p>	INPUT C	INPUT B	INPUT A	OUTPUT	0	0	0	0.00	0	0	≠0	1.00	0	≠0	0	2.00	0	≠0	≠0	3.00	≠0	0	0	4.00	≠0	0	≠0	5.00	≠0	≠0	0	6.00	≠0	≠0	≠0	7.00
INPUT C	INPUT B	INPUT A	OUTPUT																																		
0	0	0	0.00																																		
0	0	≠0	1.00																																		
0	≠0	0	2.00																																		
0	≠0	≠0	3.00																																		
≠0	0	0	4.00																																		
≠0	0	≠0	5.00																																		
≠0	≠0	0	6.00																																		
≠0	≠0	≠0	7.00																																		

Operation	Description
-----------	-------------

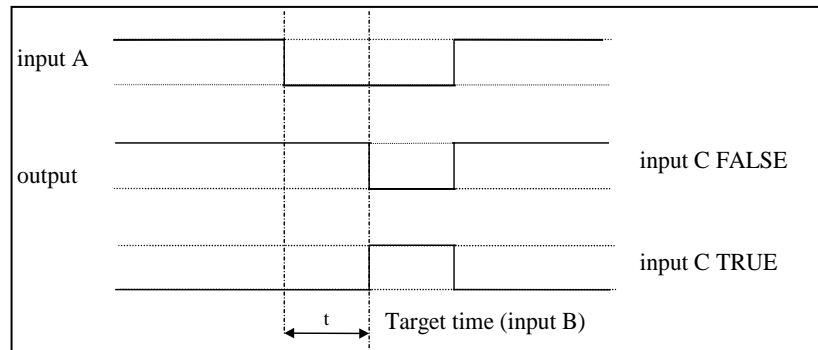
ON DELAY



A programmable delay between receiving and outputting a Boolean TRUE signal.

INPUT A becoming TRUE starts the delay timer. INPUT B sets the duration of the delay in seconds (1 = 1 second). At the end of the duration, OUTPUT becomes TRUE unless INPUT A has reverted to FALSE. Setting INPUT C to TRUE ( $\neq 0$ ) inverts the output.

OFF DELAY



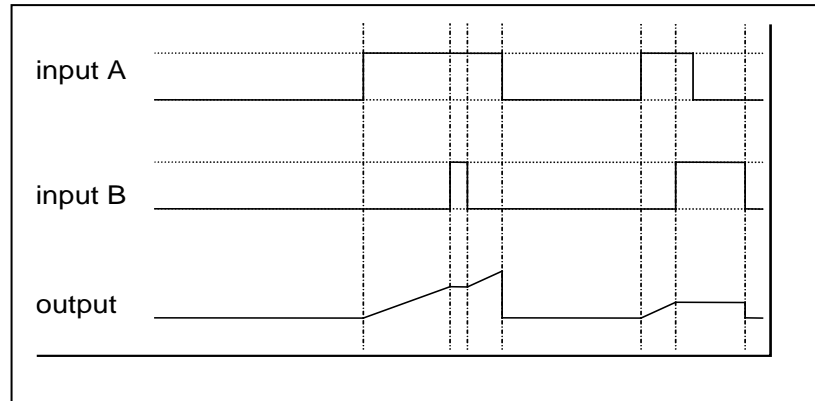
A programmable delay between receiving and outputting a Boolean FALSE signal.

INPUT A becoming FALSE starts the delay timer. INPUT B sets the duration of the delay in seconds (1 = 1 second). Setting INPUT C to TRUE ( $\neq 0$ ) inverts the output. At the end of the duration, OUTPUT becomes FALSE unless INPUT A has reverted to TRUE.



Operation	Description
-----------	-------------

TIMER

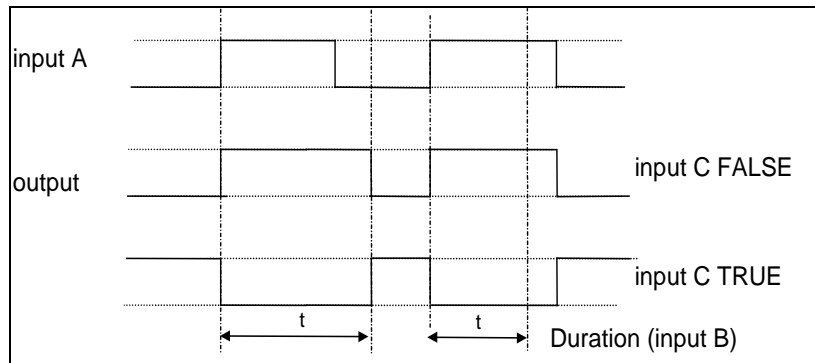


Times the period elapsed from when INPUT A is set TRUE and held TRUE, to when INPUT B becomes TRUE.

OUTPUT is the duration of the timer in seconds (1 = 1 second), starting from zero. If INPUT B is TRUE, the value for OUTPUT is held until INPUT B is released. If on release INPUT A is still TRUE, the timer will continue from the held value. Setting INPUT A and INPUT B to FALSE resets the timer.

INPUT C is not used.

MINIMUM PULSE

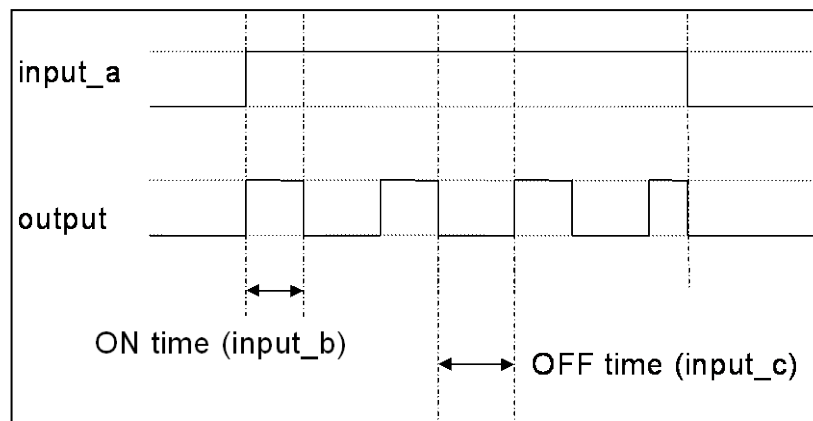


Creates an output of adjustable minimum time when INPUT A is TRUE. (INPUT A is assumed to be a sequence of TRUE pulses and FALSE off periods.)

INPUT B sets the length of the minimum pulse required in seconds (1 = 1 second). INPUT C inverts the output when TRUE. The duration of the pulse is *at least* the period set by INPUT B.

Operation	Description
-----------	-------------

PULSE TRAIN

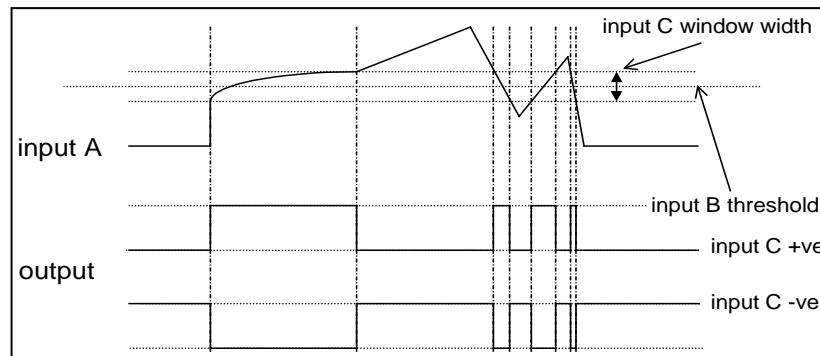


Creates a pulsed FALSE / TRUE output of programmable frequency.

INPUT A enables the pulse train when TRUE, disables when FALSE. INPUT B sets the length of the *on* part of the pulse in seconds (1 = 1 second). INPUT C sets the length of the *off* part of the pulse in seconds (1 = 1 second).

Operation	Description
-----------	-------------

WINDOW

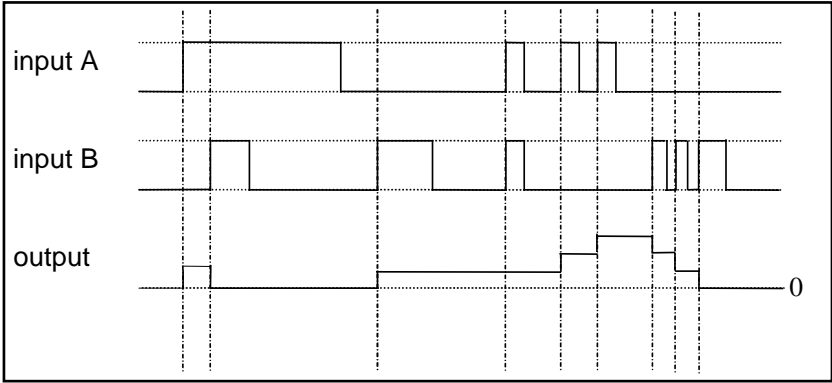


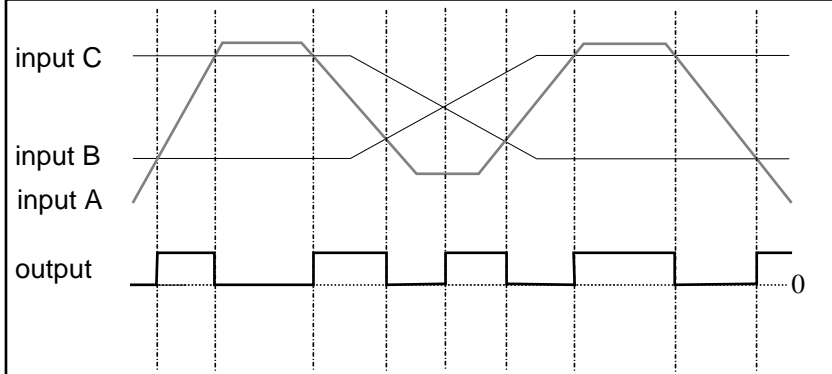
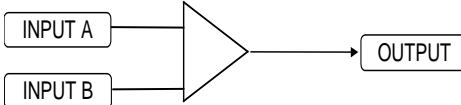
This function outputs TRUE when INPUT A is within a programmable range, and FALSE otherwise.

INPUT B sets the threshold of the window to be monitored. INPUT C defines the range of the window around the threshold. When the value of INPUT A is inside the window, the window expands by 0.01 to avoid flutter on output if noisy, i.e. if INPUT B = 5 and INPUT C = 4 then the range is 3 to 7, expanded to 2.5 to 7.5 when the value if INPUT A is inside the window.

If INPUT C is set to zero, the output will only be TRUE if INPUT A is exactly equal to INPUT B (this is fulfilled in the default condition when inputs A, B & C are all zero)

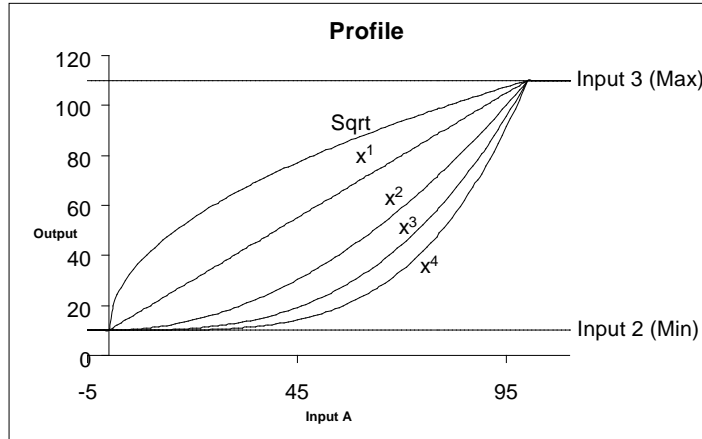
If INPUT C is set to a negative value, its absolute value defines the window range, and the output is inverted.

Operation	Description
UP/DOWN COUNTER	 <p>The diagram shows three signals over time: input A, input B, and output. Vertical dashed lines mark specific events. Input A has a rising edge that causes the output to increase by one. Input B has a rising edge that causes the output to decrease by one. The output is zero when input C is active.</p> <p>INPUT A provides a rising edge trigger to increment the output count by one.</p> <p>INPUT B provides a rising edge trigger to decrement the output count by one.</p> <p>INPUT C holds the output at zero.</p> <p>The output starts at zero. The output is limited at <math>\pm 300.00</math>.</p>
(A*B)/C ROUND	The OUTPUT is set to $(\text{INPUT A} * \text{INPUT B}) / (\text{INPUT C})$ . This is the same as (A*B)/C (enumerated value 3) except that the result is rounded.
WINDOW NO HYST	This is the same as WINDOW (enumerated value 19) except that there is no hysteresis when inside the 'window'. Thus, from the diagram given in WINDOW, if INPUT B = 5 and INPUT C = 4 then the range is 3 to 7.

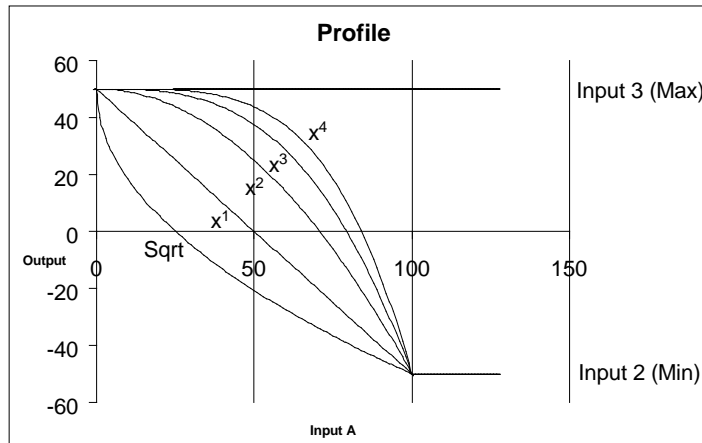
Operation	Description
WINDOW $B \leq A \leq C$	 <p>The diagram shows three input signals: input C (top), input B (middle), and input A (bottom). Input C and B form a trapezoidal band. Input A is a signal that fluctuates within and outside this band. The output signal is a square wave that is high (TRUE) when input A is within the band defined by input B and input C, and low (FALSE) otherwise. Vertical dashed lines mark the boundaries of the band.</p>
<p>INPUT B and INPUT C are the upper and lower levels of the band.</p> <p>If <math>B \leq C</math> and A is in the band then the OUTPUT is TRUE, else OUTPUT is FALSE</p> <p>If <math>C &lt; B</math> and A is in the band then the OUTPUT is FALSE, else OUTPUT is TRUE (i.e. output is inverted)</p> <p><b>Note:</b> OUTPUT is set to FALSE if the TYPE is changed or is in initialisation.</p>	
$A \leq B$	 <p>The diagram shows a logic gate with two inputs labeled 'INPUT A' and 'INPUT B', and one output labeled 'OUTPUT'. The gate is a right-pointing triangle, representing a less-than-or-equal-to comparator.</p> <p>The OUTPUT is TRUE if INPUT A is less than or equal to INPUT B, otherwise the OUTPUT is FALSE.</p>
$((A*B)/100)+C$	The OUPUT is set to $((\text{INPUT A} * \text{INPUT B})/100)+C$ .
MIN (A,B,C)	The OUTPUT is set to the smallest of INPUT A, INPUT B and INPUT C.
MAX (A,B,C)	The OUTPUT is set to the largest of INPUT A, INPUT B and INPUT C.

Operation	Description
-----------	-------------

- PROFILE SQRT
- PROFILE X^1
- PROFILE X^2
- PROFILE X^3
- PROFILE X^4



Example : Profile Min = 10, Max = 110



Example : Profile Min = 50, Max = -50

Profile functions convert an input (0-1) to an output with  $(\text{min}) + ((\text{max} - \text{min}) * \text{fn}(\text{input}))$  where  $\text{fn}()$  is Sqrt (square root), Linear ( $X^1$ ),  $X^2$ ,  $X^3$  or  $X^4$ . The output is clamped between Min and Max. The input is clamped 0-100.

The profiles are calculated from 100 point tables and linearly interpreted between the points.

PROFILE SQRT	$y = \text{min} + (\text{max} - \text{min})x^{0.5}$	PROFILE X^1	$y = \text{min} + (\text{max} - \text{min})x$
PROFILE X^2	$y = \text{min} + (\text{max} - \text{min})x^2$	PROFILE X^3	$y = \text{min} + (\text{max} - \text{min})x^3$
PROFILE X^4	$y = \text{min} + (\text{max} - \text{min})x^4$		

where INPUT A : Input x      INPUT B : Min      INPUT C : Max

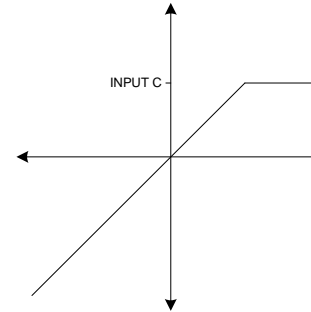
Operation	Description
ON A>B, OFF A<C	If INPUT A is greater than INPUT B then the OUTPUT is ON, (0.01). Otherwise if INPUT A is less than INPUT C then the OUTPUT is OFF, (0.00). If neither of these conditions is met then the OUTPUT is unchanged.

(A+B) CLAMPED C The OUTPUT is the result of INPUT A +, -, \* or / INPUT B, clamped by INPUT C.

(A-B) CLAMPED C

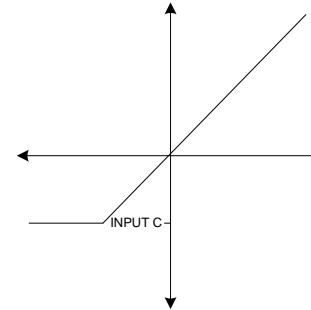
(A\*B) CLAMPED C

(A/B) CLAMPED C



**Action of clamp for when INPUT C is greater than zero**

If INPUT C is greater than 0 then the OUTPUT is clamped to INPUT C if it is greater than INPUT C.



**Action of clamp when INPUT C is negative or zero**

If INPUT C is negative or zero then the OUTPUT is clamped to INPUT C if it is less than INPUT C.

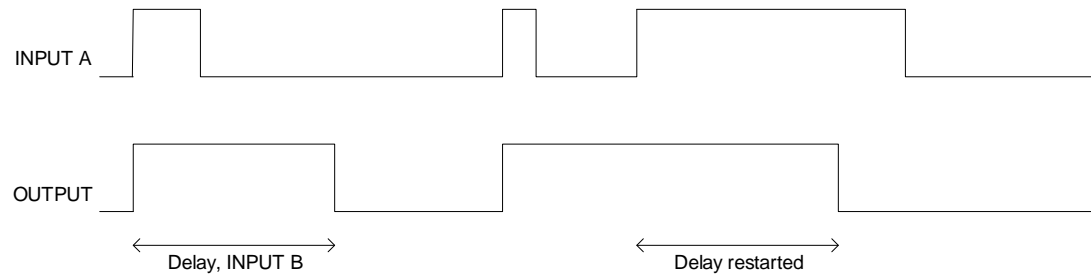
A>=B:A, A<=C:0	If INPUT A is greater than or equal to INPUT B then the OUTPUT is set to INPUT A. Otherwise if INPUT A is less than or equal to INPUT C then the OUTPUT is set to 0. If neither of these conditions is met then the OUTPUT is unchanged.
----------------	--

(A \* B) + C The OUTPUT is set to the result of (INPUT A \* INPUT B) + INPUT C.

A \* (B + C) The OUTPUT is set to the result of INPUT A \* (INPUT B + INPUT C).

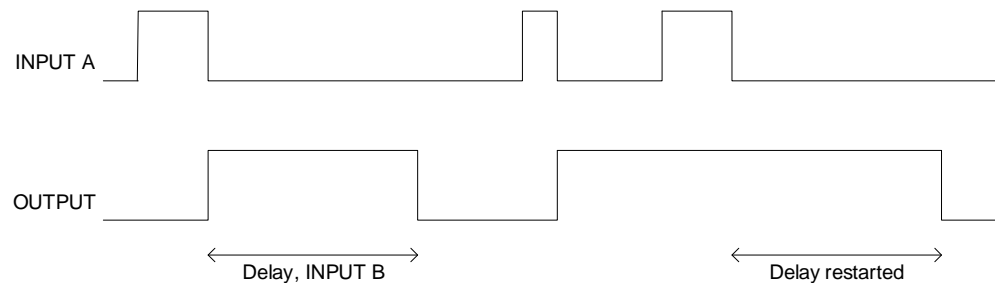
Operation	Description
$A * (B - C)$	The OUTPUT is set to the result of INPUT A * (INPUT B - INPUT C).
$A * (1+B/C)$	The OUTPUT is set to the result of INPUT A * (1.0 + (INPUT B / INPUT C)). If INPUT C is zero then the result if (INPUT B/INPUT C) will be 32768.0 for positive values of INPUT B, and -32768.0 for negative values of INPUT B.
$A * (1+(B * C))$	The OUTPUT is set to the result of INPUT A * (1.0 + (INPUT B * INPUT C)).

**MONOSTABLE HIGH** The OUTPUT is set HIGH, (0.01), on the rising edge of INPUT A. The OUTPUT remains high for a delay set by INPUT B, (in seconds). If a second rising edge reaches INPUT A while OUTPUT is high, the delay is restarted.



The OUTPUT is inverted if INPUT C is not zero.

**MONOSTABLE LOW** The OUTPUT is set HIGH, (0.01), on the falling edge of INPUT A. The OUTPUT remains high for a delay set by INPUT B, (in seconds). If a second falling edge reaches INPUT A while OUTPUT is high, the delay is restarted.



The OUTPUT is inverted if INPUT C is not zero.

**FILTER** This is a first order impulse response filter.

Input A, the value to be filtered

Input B, the time constant in seconds

Input C, Reset input.



# The Default Application

---

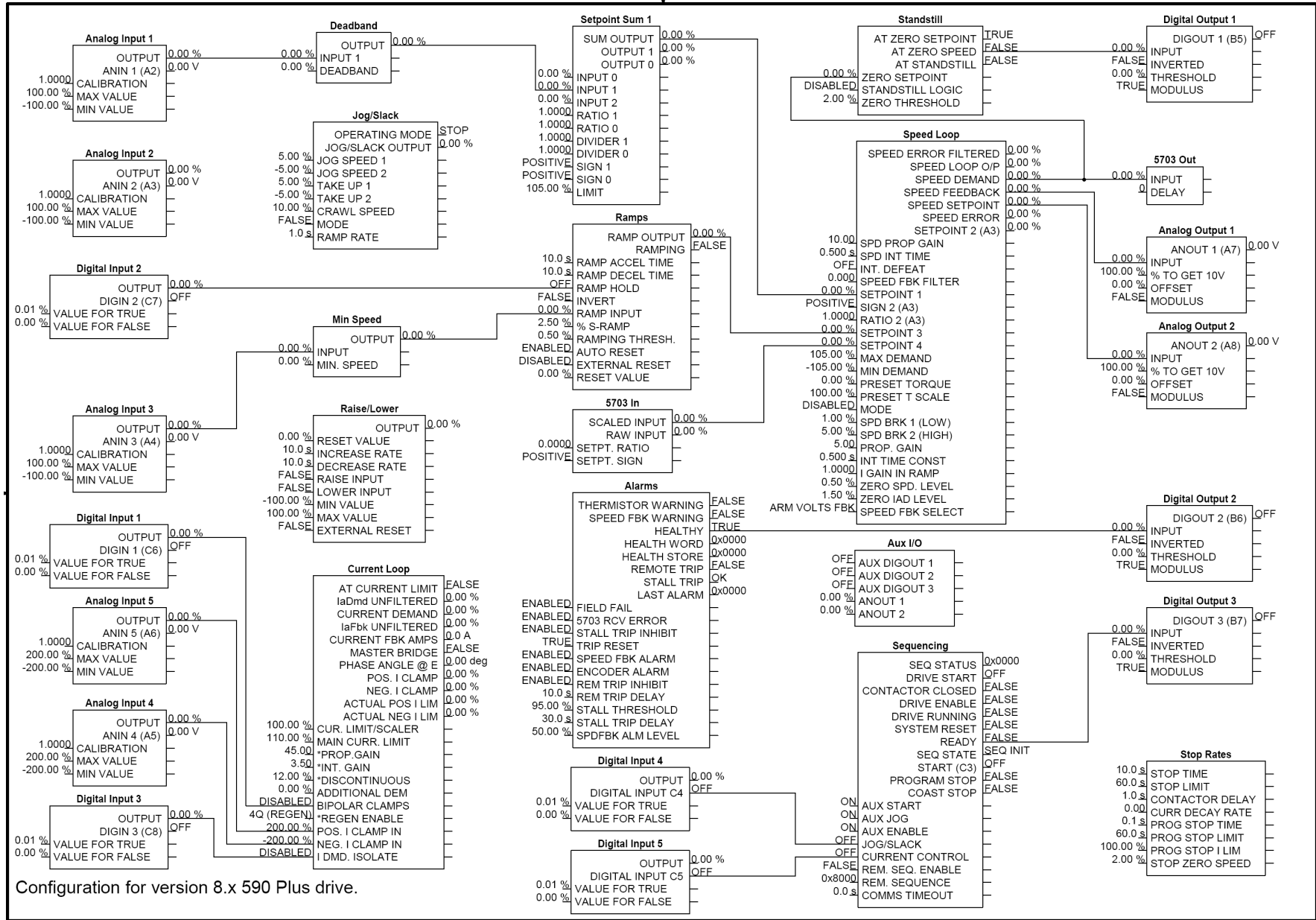
## Block Diagrams

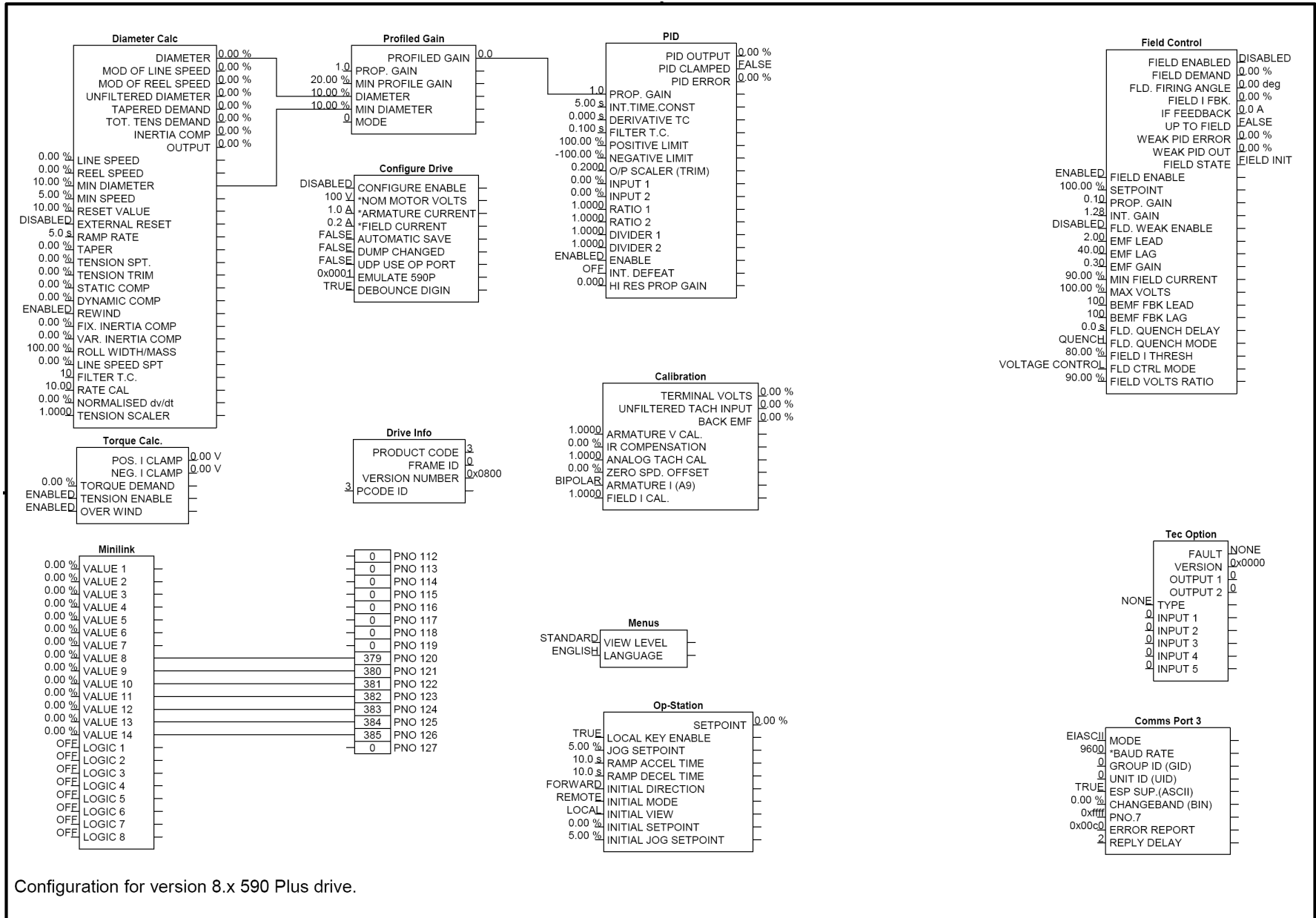
The Drive is supplied with a pre-programmed set of parameters providing for basic speed control.

The following block diagrams show this factory set-up.

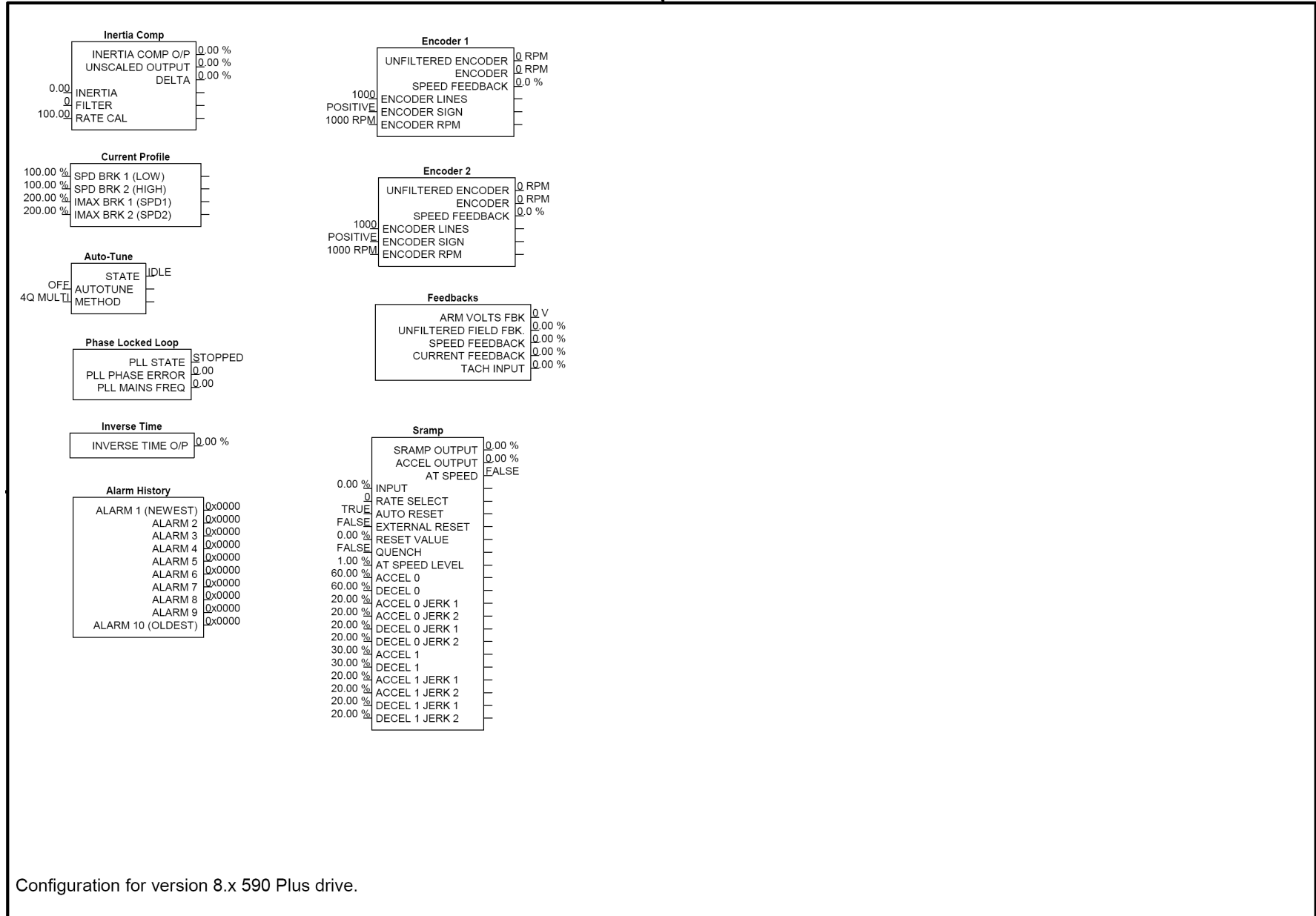
If you make any permanent changes to the block diagram, remember to update the non-volatile memory within the Drive by performing a PARAMETER SAVE. Refer to Chapter 6: “The Keypad” - Saving Your Application.

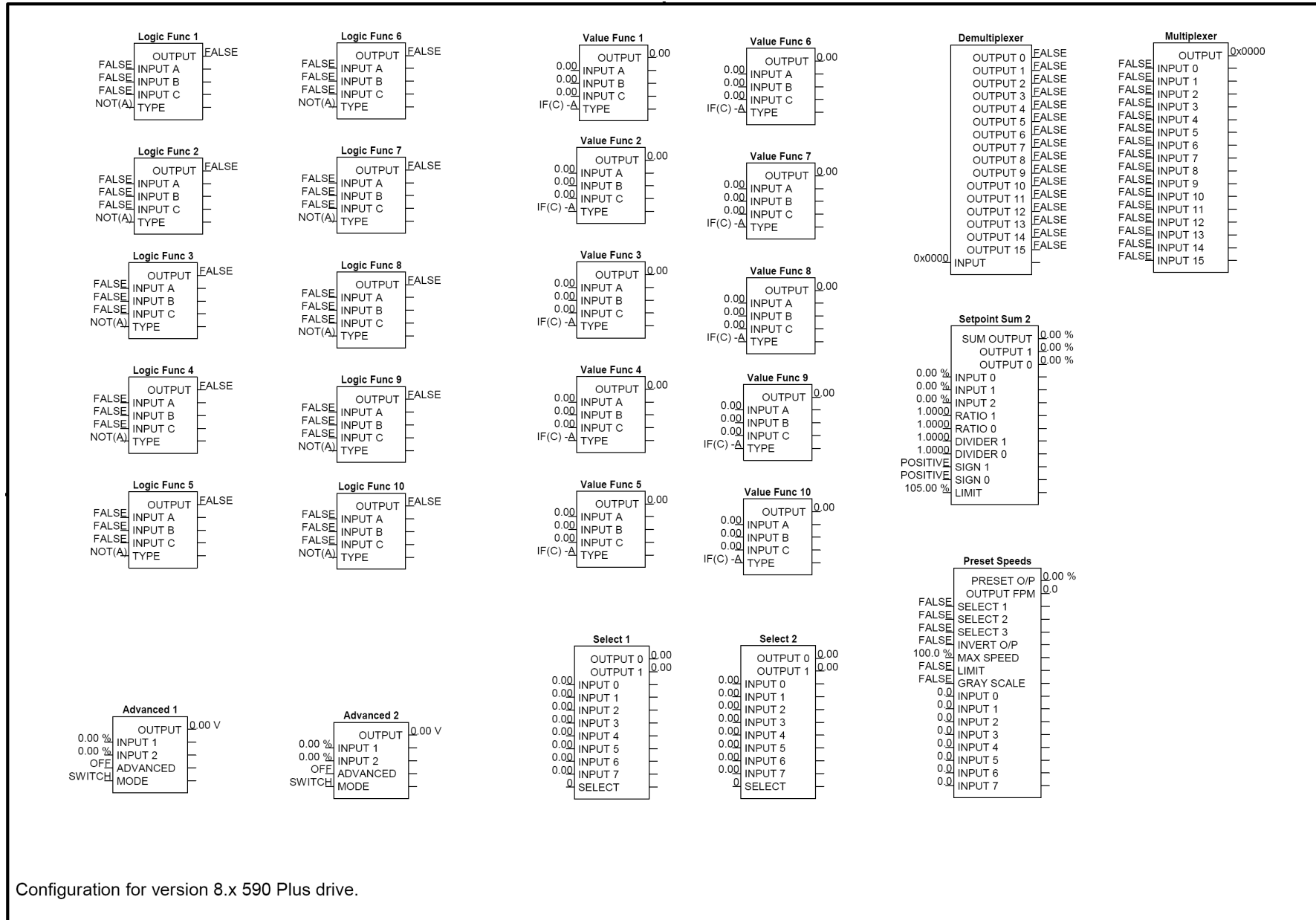
To return to the default application, refer to Chapter 6: “The Keypad” - Resetting to Factory Defaults (2-button reset).



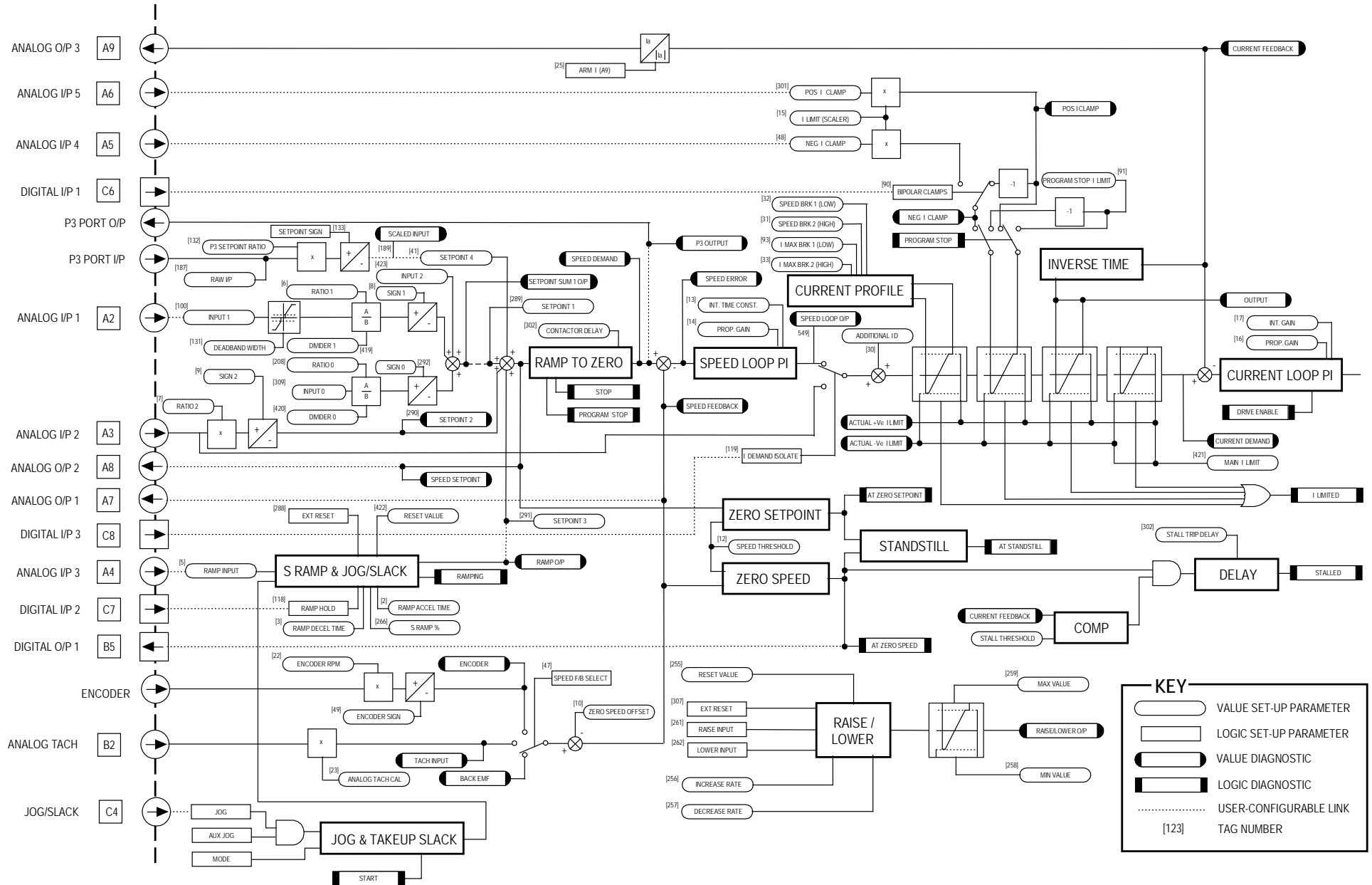


Configuration for version 8.x 590 Plus drive.



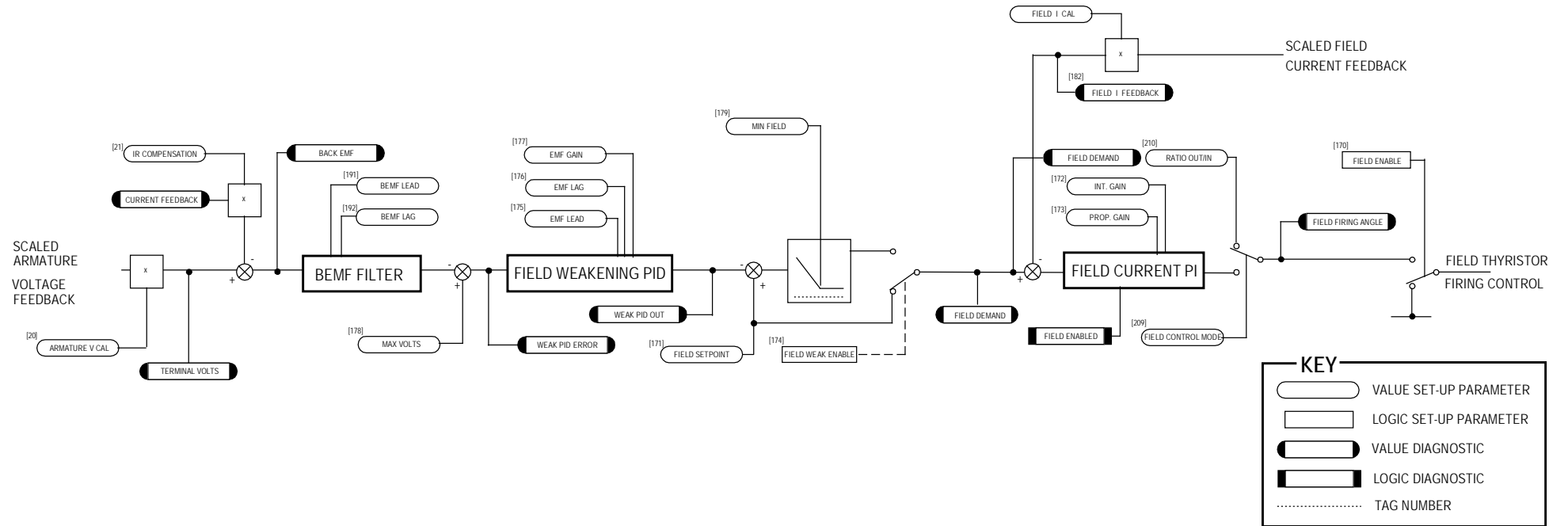


Configuration for version 8.x 590 Plus drive.

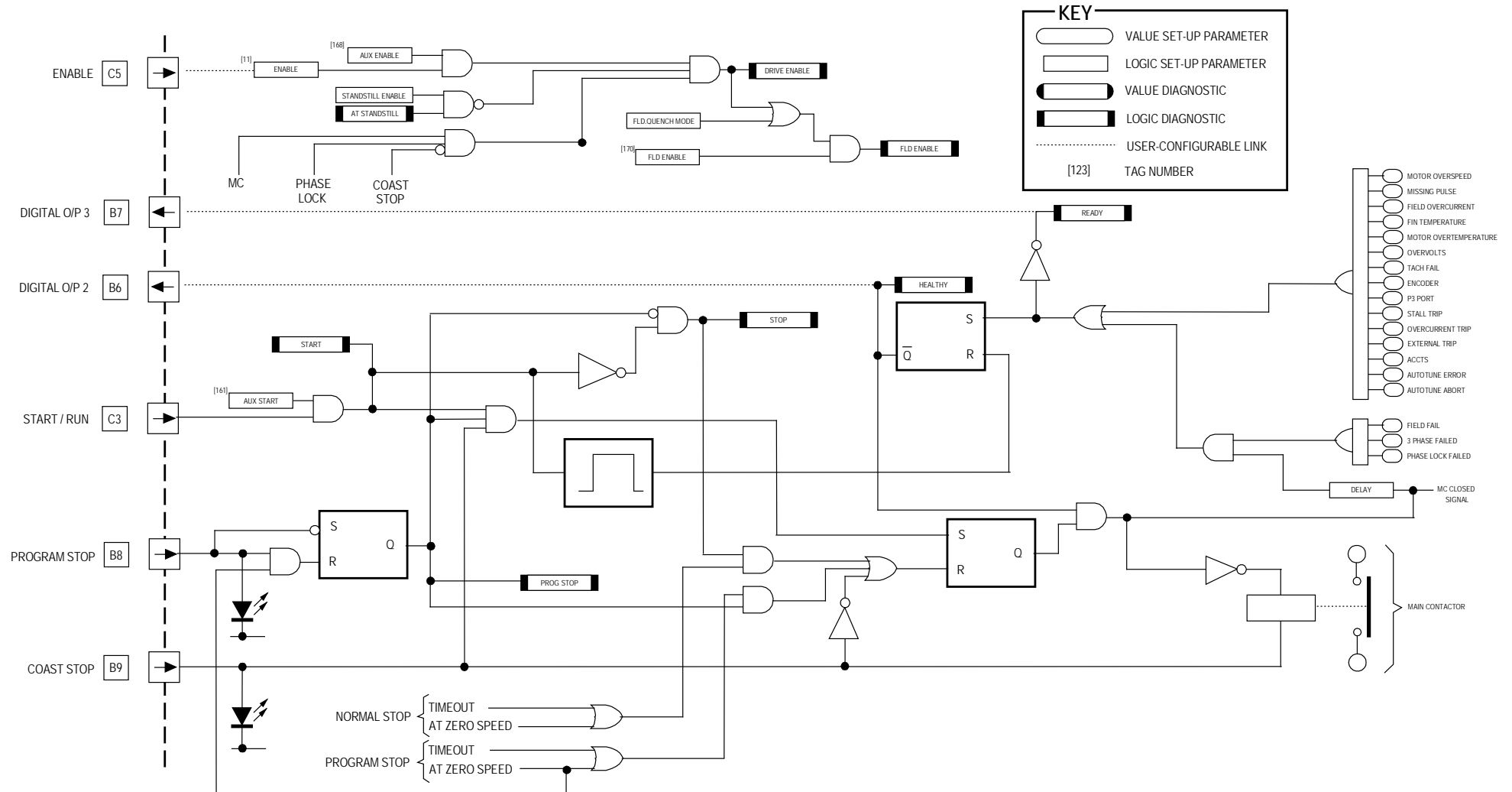


Main Block Diagram

# D-154 Programming



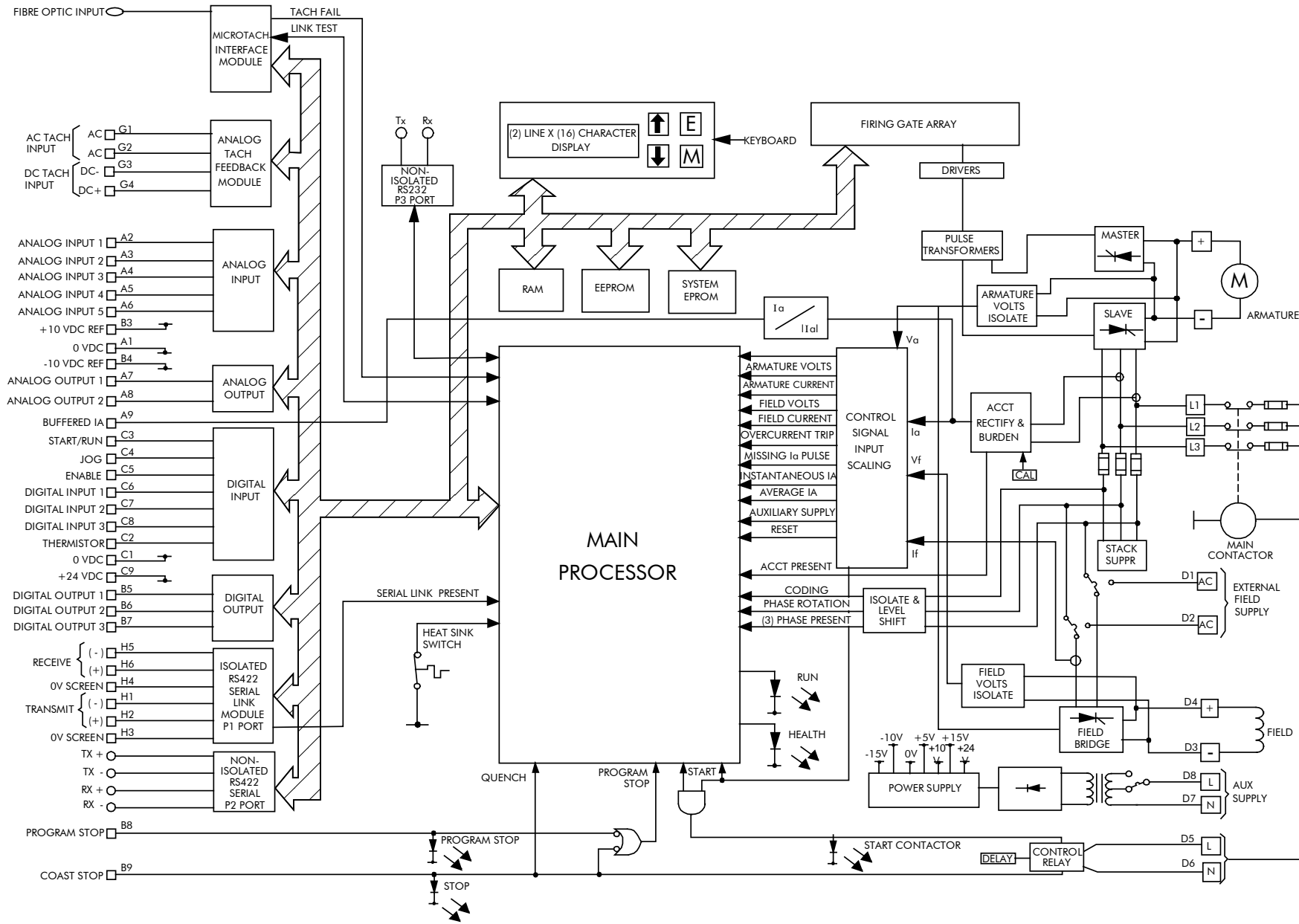
**Field Control Block Diagram**



**Start/Healthy Logic Block Diagram**



# D-156 Programming



**Functional Block Diagram**

# Appendix E **Technical Specifications**

## Technical Specifications

- Environmental Details
- Electrical Ratings - Power Circuit
- 3-Phase Power Supply Details
- Control Power Supply Detail
- AC Line Reactor (Frames 1, 2, 3, 4 & 5)
- AC Line Reactor (Frames 1, 2, 3, 4 & 5)
- Input Line Fuses (Frames 1, 2, 3, 4, & 5)
- Earthing/Grounding Safety Details
- Terminal Definitions (Digital/Analog Inputs & Outputs)
- Terminal Information - Power (Frames 1-5)
- Terminal Information - Power (Frames 6 & 7)

- Terminal Information – Control Board
- Terminal Information - Option Boards
- Wiring Requirements for EMC Compliance
- Wire Sizes and Termination Tightening Torques (Frames 1, 2, 3, 4 & 5)
- Termination Tightening Torque (Frame 6)
- Termination Tightening Torque (Frame 7)
- Dynamic Braking
- Cooling Fans
- Spares List (Frames 1-5 & 7)
- Spares List (Frame 6)



# Technical Specifications

Environmental Details	
<b>Operating Temperature</b>	Frame 1 : 0°C to +45°C (32°F to 113°F) Frame 2 : 0°C to +45°C (32°F to 113°F) Frame 3 : 0°C to +45°C (32°F to 113°F) Frame 4 : 0°C to +40°C (32°F to 104°F)* Frame 5 : 0°C to +40°C (32°F to 104°F)* Frame 6 : 0°C to +40°C (32°F to 104°F)* Frame 7 : 0°C to +40°C (32°F to 104°F)*
	* Can be enclosed in a 40°C (104°F) ambient when using the external vent kit supplied with the drive. Operating temperature is defined as the ambient temperature to the immediate surround of the drive, when the drive and other equipment adjacent to it is operating at worst case conditions. Output current values should be derated at 1% per degree Centigrade above rated temperature up to a maximum of 55°C (126°F).
<b>Storage Temperature</b>	-25°C to +55°C (-13°F to 126°F)
<b>Shipping Temperature</b>	-25°C to +70 °C (-13°F to 158°F)
<b>Product Enclosure Rating</b>	IP00 (Europe) [Frame 1 unit is IP20] UL Open Type (North America/Canada) If the product enclosure is totally enclosed, the exposed metal surface dissipates approximately 50W/m <sup>2</sup> for a 10°C temperature rise of internal air above ambient.
<b>Altitude</b>	If >500 metres (1650 feet) above sea level, derate Motor Power rating by 1% per 200 metres (660 feet) to a maximum of 2,000 metres (6,561 feet)
<b>Humidity</b>	Maximum 85% relative humidity at 40°C non-condensing
<b>Atmosphere</b>	Non flammable, non corrosive and dust free
<b>Vibration</b>	Test Fc of EN60068-2-6 10Hz<=f<=57Hz sinusoidal 0.075mm amplitude 57Hz<=f<=150Hz sinusoidal 1g 10 sweep cycles per axis on each of three mutually perpendicular axis
<b>Climatic Conditions</b>	Class 3k3, as defined by EN60721-3-3 (1995)
<b>Safety</b>	Europe EN61800-5 : 2003, when fitted inside an enclosure
	North America/Canada UL508C
	Overvoltage Category Overvoltage Category III (3-phase supply), Overvoltage Category II (auxiliary supply)
	Pollution Degree Pollution Degree 2

## E-2 Technical Specifications

### Electrical Ratings - Power Circuit

Refer to Chapter 3: "Earth Fault Monitoring Systems" for circuit breaker details.

Configuration: 8R - Two anti-parallel 3-phase thyristor bridges - Regen  
 8N - One 3-phase fully controlled thyristor bridge - Non-Regen

Motor HP ratings as NEC Table 430-147: "Full Load Current in Amperes, DC Motors"

Motor HP @ 500V dc (HP)	Power @ 500V dc (kW)	Output Current with full overload rating (A)	Nominal Supply Current (A)	Field Current (A)	Total Losses @ Full Load (W)	Symmetrical Fault Current rms (kA)
<b>Frame 1</b>						
7.5	7	15	14	4	57	5
20	15	35	32	4	117	5
<b>Frame 2</b>						
30	22	55	50	10	182	10
40	30	70	63	10	234	10
50	37	90	81	10	295	10
60	45	110	99	10	354	10
75	55	125	113	10	442	10
100	75	165	149	10	519	10
<b>Frame 3</b>						
125	100	206	186	10	780	10
150	120	243	221	10	866	10
<b>Frame 4</b>						
200	150	360	324	30	1230	18
250	187	425	383	30	1410	18
300	225	490	441	30	1590	18
400	327	700	630	30	2265	30
500	335	815	734	30	2580	30

### Electrical Ratings - Power Circuit

Refer to Chapter 3: "Earth Fault Monitoring Systems" for circuit breaker details.  
 Configuration: 8R - Two anti-parallel 3-phase thyristor bridges - Regen  
 8N - One 3-phase fully controlled thyristor bridge – Non-Regen  
 Motor HP ratings as NEC Table 430-147: "Full Load Current in Amperes, DC Motors"

Motor HP @ 500V dc (HP)	Power @ 500V dc (kW)	Output Current with full overload rating (A)	Nominal Supply Current (A)	Field Current (A)	Total Losses @ Full Load (W)	Symmetrical Fault Current rms (kA)
<b>Frame 5</b>						
600	480	1000	900	30	3090	85
700	525	1200	1080	30	3690	85
800	600	1334	1201	30	4092	85
900	670	1500	1300	30	4600	85
<b>Frame 6</b>						
700	520	1200	1100	60	4000	100
1000	750	1600	1400	60	5000	100
1200	900	1950*	1700	60	6000	100
<b>Frame 7</b>						
600	450	1050	945	60	3780	100
900	675	1450	1305	60	5280	100
1000	750	1600	1440	60	6000	100
1250	937	2000	1800	60	6780	100
1500	1120	2400	2160	60	8280	100

Output current values should be derated at 1% per degree Centigrade above rated temperature, up to a maximum of 55°C.  
 Output current values should be derated at an altitude of 500 metres (1640 feet) above sea level at a rate of 1% per 200 metres (656 feet) to a maximum of 2000 metres (6561 feet).  
 \* Derated to 1850 on HV assemblies

## E-4 Technical Specifications

3-Phase Power Supply Details			
3-Phase Supply	LV Build	All Frames	110-220V $\pm$ 10% ac, 50/60Hz $\pm$ 5%, line-to-line, earth/ground referenced (TN) and non-earth/ground referenced (IT)
	Standard	All Frames	380-500V $\pm$ 10% ac, 50/60Hz $\pm$ 5%, line-to-line, earth/ground referenced (TN) and non-earth/ground referenced (IT)
	HV Build	Frame 4 Frame 5	500-600V $\pm$ 10% ac, 50/60Hz $\pm$ 5%, line-to-line, ground referenced (TN) and non-ground referenced (IT)
	HV Build	Frame 6 & 7	380-690V $\pm$ 10% ac, 50/60Hz $\pm$ 5%, line-to-line, earth/ground referenced (TN) and non-earth/ground referenced (IT)
Supply Current		(0.9 x ARMATURE CURRENT [IA CAL]) Amps ac rms	
Field Supply Current		(1 x FIELD CURRENT [IF CAL]) Amps ac rms (build related)	
Field Supply Voltage		Build-related	
Phase		3-phase rotation insensitive, no adjustment necessary for frequency change	

Control Power Supply Detail	
Control Supply *	110V $\pm$ 10%, 50-60Hz $\pm$ 10%, single phase, Overvoltage Category II
Auxiliary Supply Current	<p>“Where auxiliary cooling fans are used, then the supply is set by the requirement for the fan, i.e. 115V <math>\pm</math> 10% or 230V <math>\pm</math> 10%.”</p> <p>Refer to the Model No. and Chapter 2: “An Overview of the Drive “ - Understanding the Product Code</p> <p>3A ac rms maximum. Nominal current used for power supplies: 0.5A at 115V ac</p> <p>Fan current for integral fans: refer to Cooling Fans, page E-27. The remainder is available for driving the AC Contactor.</p> <p>The control power is supplied by a built-in control transformer on Frame 3 and higher, providing an additional 100VA available for external control equipment.</p>
Contactor Output	3A maximum at the control voltage
* Note:	<p>Only applicable for Frames 1 &amp; 2 without the –CX option.</p> <p>The remaining drives, the control supply is generated internal to the DRV.</p>

## AC Line Reactor (Frames 1, 2, 3, 4 & 5)

To correctly isolate the 590+ DRV from the ac power system, and to protect other equipment from transients on the power system, always use the recommended external ac line reactor (or alternatively a transformer may achieve the necessary isolation).

**The Frame 5 requires two ac line reactors** (one in front of each of the paralleled drives). This provides isolating impedance between the drive and its ac power source. It also provides the necessary impedance between the paralleled drives, forcing them to share the total motor current evenly. The Frame 5 drive must still use two ac line reactors when a transformer is used for isolation, however, the reactors can be of a much lower inductance, typically 3-5μH.

DRVs with Drive Ratings below 100A cannot achieve conformance with EN61800-3 Table 11 using only a 50μH line choke. Capacitors must be fitted between phase and ground to achieve conformance.

For use without filters (use with capacitors for armature currents <100A, refer to Chapter 3: "AC Line Reactor")

Hp (240/500V) (V)	Drive Rating (A)	Reactor Current (Amps AC)	Inductance (μH)	Parker SSD Drives Part No.
<b>Frame 1</b>				
3/7.5	15	13.5	50	CO466448U015
10/20	35	36	50	CO466448U040
<b>Frame 2</b>				
10/20	40	36	50	CO466448U040
15/30	55	63	50	CO466448U070
20/40	70	63	50	CO466448U070
25/50	90	100	50	CO466448U110
30/60	110	100	50	CO466448U110
40/75	125	148.5	50	CO466448U165
50/100	165	148.5	50	CO466448U165
<b>Frame 3</b>				
60/125	206	360	50	CO057960
75/150	243	360	50	CO057960



## E-6 Technical Specifications

### AC Line Reactor (Frames 1, 2, 3, 4 & 5)

To correctly isolate the 590+ DRV from the ac power system, and to protect other equipment from transients on the power system, always use the recommended external ac line reactor (or alternatively a transformer may achieve the necessary isolation).

**The Frame 5 requires two ac line reactors** (one in front of each of the paralleled drives). This provides isolating impedance between the drive and its ac power source. It also provides the necessary impedance between the paralleled drives, forcing them to share the total motor current evenly. The Frame 5 drive must still use two ac line reactors when a transformer is used for isolation, however, the reactors can be of a much lower inductance, typically 3-5 $\mu$ H.

DRVs with Drive Ratings below 100A cannot achieve conformance with EN61800-3 Table 11 using only a 50 $\mu$ H line choke. Capacitors must be fitted between phase and ground to achieve conformance.

AC Line Reactors @ 2% line impedance for conformance with EN55011 Class A when used with specified filters:

Frame 1					
3/7.5	15	13.5	1130		CO466449U015
10/20	35	36	424		CO466449U040
Frame 2					
10/20	40	36	424		CO466449U040
15/30	55	63	242		CO466449U070
20/40	70	63	242		CO466449U070
25/50	90	100	154		CO466449U110
30/60	110	100	154		CO466449U110
40/75	125	148.5	103		CO466449U165
50/100	165	148.5	103		CO466449U165
Frame 3					
60/125	206	360	50		CO057960
75/150	243	360	50		CO057960
AC Line Reactors @ 1% line impedance for conformance with EN55011 Class A when used with specified filters:					
Frame 4					
200	360	342	30 $\mu$ H		CO466709U038
250	425	450	25 $\mu$ H		CO466709U050
300	490	450	25 $\mu$ H		CO466709U050
400	700	653	20 $\mu$ H		CO466709U073
500	815	747	15 $\mu$ H		CO466709U083
Frame 5 (2 AC Line Reactors required)					
600	1000	653	20 $\mu$ H		CO466709U073
700	1200	653	20 $\mu$ H		CO466709U073
800	1334	747	15 $\mu$ H		CO466709U083
Use with transformer only:					
600	1000	567	5 $\mu$ H		CO466709U120
700	1200	567	5 $\mu$ H		CO466709U120
800	1334	747	5 $\mu$ H		CO466709U160

# Input Line Fuses (Frames 1, 2, 3, 4, & 5)

For fuses where compliance to UL Standards are required, refer to Chapter 12: "Installing the Drive" - Requirements for UL Compliance.

**Input Line Semiconductor Fuses are internally fitted on all DRV units**

**Armature Semiconductor Fuses are fitted on Regenerative DRV units**

Drive Rating (Hp @ 240/500V)                      (A)		Line Fuses (Parker SSD Part #)	Armature Fuses (Parker SSD Part #)
<b>Frame 1</b>			
3/7.5	15	A60Q40 (CS470407U040)	A70QS50-14F (CS470445U050)
10/20	35	A60Q40 (CS470407U040)	A70QS50-14F (CS470445U050)
<b>Frame 2</b>			
15/30	55	A50QS80 (CS350261)	A70QS80 (CS350428)
20/40	70	A50QS80 (CS350261)	A70QS80 (CS350428)
25/50	90	A50QS125 (CS350262)	A70QS150 (CS350263)
30/60	110	A50QS125 (CS350262)	A70QS150 (CS350263)
40/75	125	A50QS200 (CS470408U200)	A70QS200 (CS470469U200)
50/100	165	A50QS200 (CS470408U200)	A70QS200 (CS470469U200)
<b>Frame 3</b>			
60/125	206	A50P300-4 (CS350265)	A70QS350-4 (CS352024)
75/150	243	A50P300-4 (CS350265)	A70QS350-4 (CS352024)
<b>Frame 4</b>			
200	360	A070URD32KI0400 (CS470689U0400)	A130URD73L10450 (CS470690U0450)
250	425	A070URD32KI0500 (CS470689U0500)	A130URD73L10630 (CS470690U0630)
300	490	A070URD32KI0630 (CS470689U0630)	A130URD73L10700 (CS470690U0700)
400	700	A070URD32KI0800 (CS470689U0800)	A130URD73L10900 (CS470690U0900)
500	815	A070URD32KI0900 (CS470689U0900)	14URD93TT1250 (CS470690U1250)
<b>Frame 5</b>			
600	1200	A070URD32KI0630 CS470689U0630 (6 per drive)	12URD93TF1500 (CS470690U1500)
700	1334	A070URD32KI0700 (CS470689U0700 (6 per drive)	11URD93TF2000 (CS470690U2000)
800	1500	A070URD32KI0800 (CS470689U0800 (6 per drive)	11URD93TF2000 (CS470690U2000)
900		A070URD32KI0900 (CS470689U0900 (6 per drive)	12,5URD94TDF2300N (CS470690U2300)

## E-8 Technical Specifications

<b>Earthing/Grounding Safety Details</b>	
<b>Grounding</b>	<p>Permanent earthing is mandatory on all units because the earth leakage current exceeds 3.5mA ac/10mA dc under normal operating conditions. Permanent earthing can be laid in two ways::</p> <ol style="list-style-type: none"><li>1. By using a copper conductor of at least 10mm<sup>2</sup> cross-sectional area.</li><li>2. By using a second conductor, through separate terminals electrically parallel to the protective conductor.</li></ol> <p><b>Note:</b> Each conductor itself must meet the local requirements for a protective earth conductor.</p>
<b>Input Supply Details (TN) and (IT)</b>	<p>Units with or without external filters are suitable for use on earth referenced (TN) supplies, but units used with a filter are not recommended for non-earth referenced (IT) supplies.</p>
<b>Ground Leakage Current</b>	<p>&gt;50mA (all models)</p>

<h3 style="text-align: center;">Terminal Definitions (Digital/Analog Inputs &amp; Outputs)</h3> <p style="text-align: center;">User inputs are IEC1131 compliant. Terminal blocks A, B, and C are located on the control board each block being a 9 way plug-in connector. In addition to terminal blocks A, B and C, terminal blocks G and H provide connections when the two option modules are fitted on the control board.</p>		
<p>Digital Input</p>	<p>Rated Voltage:</p> <ul style="list-style-type: none"> <li>• Off Region</li> <li>• Transition Region</li> <li>• On Region</li> </ul> <p>Input Impedance Sample Interval Debounce Period Encoder Mode (Digital Input 1 &amp; 2):</p> <ul style="list-style-type: none"> <li>• SPACE Region</li> <li>• Transition Region</li> <li>• MARK Region</li> </ul> <p>Maximum Clock Frequency</p>	<p>24V dc -3V to +5V, min.current not defined, max. 15mA +5V to +15V, min.0.5mA, max. 15mA +15V to +30V, min. 2mA, max. 15mA Nominally 3.3kΩ 5ms 3ms 5V logic -3V to +0.5V +0.5V to +3V +3V to +30V 100kHz</p>
<p>Digital Output</p> <p>These outputs are active high and source current from the terminal to the load. Thus the load must be connected between the output and the signal ground. A free-wheel diode is included in the output to protect the output transistor when switching inductive loads such as relays.</p>	<p>Digital Output Voltage Output Update Interval Output Impedance Source/Sink Rated Current Temporary Overload Overload Protection Overload Recover Reverse Voltage Protection Operating Voltage Off state leakage current</p>	<p>Nominally +24V dc 5ms Negligible up to 50mA load Source +100mA maximum source None Indefinite short circuit protection provided Automatic Protected against current-limited reverse voltage sources (&lt;100mA) &lt;30V dc &lt;0.4mA sourcing</p>
<p>Analog Input</p>	<p>Input Resolution Input Impedance Input Impedance Limit Sample Interval Hardware Latency Overload Capability</p>	<p>12 Bit plus sign, i.e. 2.5mV resolution, equals 0.025% of full scale deflection 112kΩ ≥10kΩ (signal range -10V to +10V) 5ms, and just-in-time for control loops on Analog I/P 2 (A3), min. 5ms 1.3ms filter for Analog I/P (A3) and 2.5ms for others. +10%, i.e. maximum recognisable voltage +/-11V. Analog Tachogenerator input should be applied to Terminal G3 on Calibration Option Card only.</p>

## E-10 Technical Specifications

### Terminal Definitions (Digital/Analog Inputs & Outputs)

User inputs are IEC1131 compliant. Terminal blocks A, B, and C are located on the control board each block being a 9 way plug-in connector. In addition to terminal blocks A, B and C, terminal blocks G and H provide connections when the two option modules are fitted on the control board.

Analog Output	Output Resolution Output Drive Capacity Update Interval Settling Time Output Overdrive Capability Overload Protection	11 Bit plus sign, i.e. 5mV resolution, equals 0.05% of full scale deflection 10V at 5mA max. 5ms 5ms, for 0% to 90% +10%, i.e. maximum output +/-11V at 2.5mA max. Indefinite short circuit protection provided
---------------	--	--

### Terminal Information - Power (Frames 1-5)

**Note:** On Frame 1 and 2 units, L1, L2, L3, A+ and A- terminals are located on a separate Terminal Board. On Frame 3, 4 & 5 units, they are busbar connections.

Terminal Description	Terminal Function	Signal Level	Customer Terminals	
			Frames 1, 2	Frames 3, 4, 5
Mains Supply L1	Three phase mains power input, phase reference Line 1	500Vac maximum 50-60Hz line-to-line	L1	L1
Mains Supply L2	Three phase mains power input, phase reference Line 2	500Vac maximum 50-60Hz line-to-line	L2	L2
Mains Supply L3	Three phase mains power input, phase reference Line 3	500Vac maximum 50-60Hz line-to-line	L3	L3
Armature connection positive A+	Drive dc power output, reference Armature Positive connection to dc motor	550Vdc maximum with respect to A- (maximum voltage dependent upon the supply voltage, the ratio being: $V_{out}$ is approximately equal to 1.15Vac supply	A+	A+

## Terminal Information - Power (Frames 1-5)

**Note:** On Frame 1 and 2 units, L1, L2, L3, A+ and A- terminals are located on a separate Terminal Board. On Frame 3, 4 & 5 units, they are busbar connections.

Terminal Description	Terminal Function	Signal Level	Customer Terminals	
			Frames 1, 2	Frames 3, 4, 5
Armature connection negative A-	Drive dc power output, reference Armature Negative connection to dc motor	550Vdc maximum with respect to A+ (maximum voltage dependent upon the supply voltage, the ratio being: Vout is approximately equal to 1.15Vac supply	A-	A-
Auxiliary N/C Volt-Free MC Contact : 1, 2	Used to indicate the status of the main contactor (L1, L2, L3). See TB4.	-	1, 2	
External field supply FL1	External single phase ac Line 1 input to field bridge.	500V ac maximum, 50-60Hz line-to-line	FL1	
External field supply FL2  <b>This feature not available on Frame 1 units</b>	<p>External single phase ac Line 2 input to field bridge.</p> <p>Required AC Input Voltage = 1.11 x Nominal DC Output.</p> <p>The field regulator will control the field current provided that the Nominal DC Output voltage exceeds the field voltage by at least 10%.</p> <p>i.e.                    <math>V_{AC} = 1.11 \times V_{DC}</math>                                      and        <math>V_{DC} = 1.1 \times V_{FIELD}</math>                                      therefore <math>V_{AC} = 1.22 \times V_{FIELD}</math></p> <p>The external AC supply must be fitted with high speed fuses to protect the field regulator. For drives with 10A field capability 10A fuses should be used.</p> <p><i>Note: When using an external ac input it is important to have the correct phase relationship on the terminals. The supply must be derived from L1 (Red) and L2 (Yellow) phases directly or indirectly through a transformer. L1 must be connected to FL1, and L2 to FL2.</i></p>	500V ac maximum, 50-60Hz line-to-line	FL2	

## E-12 Technical Specifications

### Terminal Information - Power (Frames 1-5)

**Note:** On Frame 1 and 2 units, L1, L2, L3, A+ and A- terminals are located on a separate Terminal Board. On Frame 3, 4 & 5 units, they are busbar connections.

Terminal Description	Terminal Function	Signal Level	Customer Terminals	
			Frames 1, 2	Frames 3, 4, 5
Field Output F-	<p>DC supply for motor field connections.</p> <p>The DC output voltage at these terminals will depend upon the AC supply voltage and the mode of field control.</p> <p><b>Voltage Control</b></p> <p>The output voltage will be determined by the ratio parameter in the field variables. The relationship between the dc output voltage and AC input voltage is determined by the equation:-</p> $V_{dc} = \frac{V_{ratio} \times V_{AC}}{100}$ <p>The default value of Vratio is 90% hence the DC output voltage will be the same as for a full wave diode rectifier, i.e., 90% is maximum output.</p>	0.9 x Vac	F-	F-
Field Output F+	DC supply for motor field connections.	0.9 x Vac	F+	F+
Auxiliary supply Aux N	Neutral	115V 50-60Hz line-to-line	CONTROL N	L7
Auxiliary supply Aux L	<p>Line</p> <p>These terminals are the mains input connections for the switch mode power supply and contactor control relay supply.</p>	115V 50-60Hz line-to-line	L	L6  <b>Do not connect external control power if using the control transformer option</b>

## Terminal Information - Power (Frames 1-5)

**Note:** On Frame 1 and 2 units, L1, L2, L3, A+ and A- terminals are located on a separate Terminal Board. On Frame 3, 4 & 5 units, they are busbar connections.

Terminal Description	Terminal Function	Signal Level	Customer Terminals	
			Frames 1, 2	Frames 3, 4, 5
Main contactor coil Con L	Line  This terminal is the switched output from the contactor control relay and is derived from the auxiliary supply at terminal D8. The output is internally fused at 3A hence contactor coils having a high pick-up current must be operated via a slave relay.  <i>Note: The contacts of the Contactor Control Relay are suppressed by a series connected resistor (680 Ohms) and capacitor (22nF) to protect the relay contacts. Users should be aware that when the contactor Control Relay is "De-energised", a leakage current of approximately 2mA can be expected and this should be considered when interfacing to these terminals. Typically, there could be the energisation of very sensitive relays.</i>	115V 50-60Hz line-to-line	EXT CONTACTOR L	L
Main contactor coil Con N	Neutral  This terminal is internally connected to the auxiliary supply neutral and provides a convenient connection point for the contactor coil neutral connection.	115V 50-60Hz line-to-line	N	N
Thermistor Therm +	Isolated Thermistor Input – positive  It is good practice to protect DC motors against sustained thermal overloads by fitting temperature sensitive resistors or switches in the field and interpole windings of the machine.  The drive complies with the requirements of IEC 34-11-2-2 and is suitable for use with Mark A detectors.  These devices have a low resistance (typically 200Ω) up to a reference temperature 125°C). Above this temperature, their resistance rises rapidly to greater than 4kΩ. The preferred installation is for three detectors to be connected in series between terminals Th1 and Th2.  The 590+ will indicate a motor overtemperature alarm if the external resistance between Th1 and Th2 exceeds 3kΩ. The alarm can be reset when the resistance falls below 750Ω.  Terminals Th1 and Th2 must be jumpered if overtemperature sensors are not used.	See description	MOTOR THERMISTOR Th1 (THERM+)  (THERM+ & THERM –, found on Frame 3 units, are located on a separate pcb to the left of the power board in the door assembly)	TH1
Thermistor Therm -	Isolated Thermistor Input – negative See description above	See description	Th2 (THERM-)	TH2
STUDS	Protective earth/ground - incoming earth/ground	-	PE	PE
STUDS	Protective earth/ground - motor earth/ground	-	PE	PE
STUDS	Protective earth/ground	-	PE	PE



## E-14 Technical Specifications

Terminal Information - Power (Frames 6 & 7)		
These terminals are located externally on the product.		
Terminal Description	Terminal Function	Terminal Number
Three phase supply	Drive supply	L1 - L3
Armature + Armature -	Drive output to motor armature Drive output to motor armature	A+ A-
External field supply (Red Phase) External field supply (Yellow Phase)	External single phase ac Line 1 input to field bridge.  External single phase ac Line 2 input to field bridge.  Required AC Input Voltage = 1.11 x Nominal DC Output. The field regulator will control the field current provided that the Nominal DC Output voltage exceeds the field voltage by at least 10%. i.e. $V_{AC} = 1.11 \times V_{DC}$ and $V_{DC} = 1.1 \times V_{FIELD}$ therefore $V_{AC} = 1.22 \times V_{FIELD}$  The external AC supply must be fitted with high speed fuses to protect the field regulator. For controllers with 10A field capability 10A fuses should be used, those with 20A field capability 20A fuses, etc. <i>Note: When using an external AC input it is important to have the correct phase relationship on the terminals. The supply must be derived from L1 (Red) and L2 (Yellow) phases directly or indirectly through a transformer. L1 must be connected to FL1, and L2 to FL2.</i>	FL1  FL2
Field Output (DC+) Field Output (DC-)	DC supply for motor field connections.  DC supply for motor field connections.  The DC output voltage at these terminals will depend upon the AC supply voltage and the mode of field control. Maximum drive field output capability is 60A DC.	F+  F-
External Armature Volts Sense (+) External Armature Volts Sense (-)	This connection can be used if a more accurate value of armature voltage is required, for example a DC line reactor may be fitted. This terminal should be connected directly to the positive motor armature terminal.  This terminal should be connected directly to the negative motor armature terminal (see above).	MVA+  MVA-

Terminal Information - Power (Frames 6 & 7)		
These terminals are located externally on the product.		
Auxiliary Supply Live 115-230V Frame 6	These terminals are the mains input connections for control supply transformer and contactor relay supply	L
Auxiliary Supply Live 110-240V Frame 7		
Auxiliary Supply Neutral		N
Main contactor coil V AC	This terminal is internally connected to the auxiliary supply neutral and provides a convenient connection point for the contactor coil neutral connection	N
Main contactor coil V AC	This terminal is the switched output from the contactor control relay and is derived from the auxiliary supply. The output is internally fused at 3A hence contactor coils having a high pick-up current must be operated via a slave relay.  <i>Note: The contacts of the Contactor Control Relay are suppressed by a series connected resistor (680 Ohms) and capacitor (22nF) to protect the relay contacts. Users should be aware that when the contactor Control Relay is "De-energised", a leakage current of approximately 2mA can be expected and this should be considered when interfacing to these terminals. Typically, there could be the energisation of very sensitive relays.</i>	C

## E-16 Technical Specifications

Terminal Information – Control Board					
This Control Board is common to all 590 units.					
Terminal Description	Terminal Function	Signal Level		Configurable	Terminal Number
<b>TERMINAL BLOCK A</b>					
0V (Signal)	Zero Volt Reference	0V		N/A	A1
Analog Input 1	Speed Setpoint No. 1	+10V =	Full speed setpoint forward	YES	A2
		-10V =	Full speed setpoint reverse		
Analog Input 2	Aux. Speed Setpoint/ Current Demand  The function of this input is determined by Digital Input No. 3 at terminal C8. C8 open circuit = Speed Setpoint C8 at +24V = Current Demand	+10V =	Full speed setpoint forward	NO	A3
		-10V =	Full speed setpoint reverse in speed setpoint mode.		
		+10V =	100% Positive current demand.		
		-10V =	100% Reverse current demand.		
Analog Input 3	Ramped Speed Setpoint	+10V =	Full speed setpoint	YES	A4
		-10V =	Full speed setpoint reverse		
Analog Input 4	Aux. Current Clamp -ve	+10V =	200% Positive current demand	YES	A5
		-10V =	200% Reverse current clamp		
Analog Input 5	Main Current Limit/ Aux. Current Clamp +ve  Note that unused analog inputs should be connected to 0V (Signal), or disconnected from the block diagram, in order to reduce signal noise.			YES	A6
	The function of analog inputs 4 and 5 is determined by digital Input No.1 on terminal C6. C6 open circuit: Analog inputs No.5 = Main Current Limit. C6 at +24V: Analog input No. 5 = Auxiliary Current Clamp Positive. Analog Input No. 4 = Auxiliary Current Clamp Negative.				

Terminal Information – Control Board				
This Control Board is common to all 590 units.				
Terminal Description	Terminal Function	Signal Level	Configurable	Terminal Number
Analog Output 1	Speed Feedback	+10V = Full speed feedback forward. -10V = Full speed feedback reverse.	YES	A7
Analog Output 2	Total Speed Setpoint	+10V = Full speed feedback forward. -10V = Full speed feedback reverse.	YES	A8
Current Meter Output	Buffered Armature Current Output The output can be selected as either Bipolar or Unipolar by the Armature I parameter.	<u>Bipolar Mode</u> +10V = 200% output current forward. -10V = 200% output current reverse. <u>Unipolar Mode</u> +10V = 200% output current.	NO	A9
TERMINAL BLOCK B				
0V (Signal)	Zero Volt Reference	0V	N/A	B1
Not Connected	Not Connected			B2
+10V DC Reference	User +10V Reference	+10V at 10mA short circuit protected	N/A	B3
-10V DC Reference	User -10V Reference	-10V at 10mA short circuit protected	YES	B4
Digital Output 1	Zero Speed Detected The operating level of this output can be modified by the standstill zero threshold parameter to give the desired accuracy of operation	+24V at zero speed (100mA maximum)	YES	B5
Digital Output 2	Drive Healthy (Drive Operational) This output is true when the controller is Healthy.	+24V when Healthy (100mA maximum)	YES	B6
Digital Output 3	Drive Ready This output is true when the controller is ready to function, i.e., "locked" into the mains.	+24V when Ready (100mA maximum)	YES	B7

## E-18 Technical Specifications

Terminal Information – Control Board				
This Control Board is common to all 590 units.				
Terminal Description	Terminal Function	Signal Level	Configurable	Terminal Number
Program Stop Input	<p>Program Stop</p> <p>When the Program Stop input is held at +24V, the drive operates as required by the inputs. When the Program Stop is open circuit or at zero volts, the controller provides a controlled or program stop as defined by the Program Stop parameters.</p>	<p>+24V drive run</p> <p>0V (o/c) drive program stop</p> <p>Threshold +16V</p>	NO	B8
Coast Stop Input	<p>Coast Stop</p> <p>When the Coast Stop input is at +24V, the controller operates normally. When the Coast Stop is at zero volts or open circuit, the main contactor is open and the drive no longer operates. The motor coasts to rest.</p>	<p>+24V drive run</p> <p>0V (o/c) drive coasts to rest.</p> <p>Threshold +16V</p>	NO	B9
<b>TERMINAL BLOCK C</b>				
0V (Signal)	Zero Volt Reference	0V	N/A	C1
External Trip Input	An external interlock or permissive.	<p>External permissive element should be connected to C1 to run.</p> <p>If not using this feature, connect a jumper between C1 and C2.</p> <p>May be used as an unisolated motor thermal input</p>	NO	C2
Start/Run Input	<p>Start/Run</p> <p>When an input is applied to this terminal, the main contactor will close and the controller will operate provided there are no alarms, program stop/coast stop signals are high and the controller is enabled. When the input is removed the controller will perform a regenerative stop to zero speed. A regenerative stop can only be achieved by a 4 quad regenerative controller; the 2 quad non-regenerative controller will coast to zero speed.</p>	<p>+24V = True/Run</p> <p>0V (o/c) = False/Normal Stop</p> <p>Threshold + 16V</p>	NO	C3

Terminal Information – Control Board				
This Control Board is common to all 590 units.				
Terminal Description	Terminal Function	Signal Level	Configurable	Terminal Number
Jog Input	<p>Jog</p> <p>When the Jog Input is held at +24V, the drive jogs provided input C3 is low. When the Jog Input is removed the drive will ramp down to zero obeying the Jog Ramp Rate.</p>	<p>+24V = True/Jog</p> <p>0V = False/Stop</p> <p>Threshold +16V</p>	YES	C4
Enable Input	<p>Enable</p> <p>The Enable Input provides a means of electronically inhibiting controller operation. If the enable input is not true all control loops will be inhibited and the controller will not function.</p>	<p>+24V = True/Enable</p> <p>0V = False/Inhibit</p> <p>Threshold +16V</p>	YES	C5
Digital Input 1	<p>Current Clamp Select</p> <p>This input alters the configuration of the current clamps. With no connection, i.e., false, Analog I/P 5 provides a unipolar current limit. When true, Analog I/P5 is the positive current clamp, Analog I/P 4 is the negative current clamp.</p>	<p>+24V = True/Bipolar Clamp</p> <p>0V = False/Unipolar Clamp</p> <p>Threshold +16V</p>	YES	C6
Digital Input 2	<p>Ramp Hold</p> <p>If the input is held true the S-Ramp output is frozen at the last value irrespective of the Ramped Setpoint Input. When false the S-Ramp Output follows the Ramped Setpoint Input with a delay determined by the Acceleration and Deceleration Ramped time parameters.</p> <p>Access encoder mode set-up &amp; output parameters via the ENCODER 2 function block.</p>	<p>+24V = True/Hold</p> <p>0V = False/Ramp</p> <p>Threshold + 16V</p> <p>Encoder CLK/DIRECTION Mode: CLOCK INPUT</p> <p>+5V to +24V = MARK</p> <p>0V = SPACE</p>	YES	C7

## E-20 Technical Specifications

Terminal Information – Control Board				
This Control Board is common to all 590 units.				
Terminal Description	Terminal Function	Signal Level	Configurable	Terminal Number
Digital Input 3	<p>Current Demand Isolate</p> <p>This input alters the drive operation from Speed Control to Current Control. When digital input No. 3 is true, analog input No. 2 provides the current demand and the speed loop is disconnected. When false the speed loop is in control and analog input No. 2 is an auxiliary speed setpoint.</p> <p>Access encoder mode set-up &amp; output parameters via the ENCODER 2 function block.</p>	<p>+24V = True/Current</p> <p>0V = False/Speed</p> <p>Threshold + 16V</p> <p>Encoder CLK/DIRECTION Mode: DIRECTION INPUT +5V to +24V, or 0V</p>	YES	C8
+24V Supply	+24V	<p>Maximum output current: 200mA</p> <p>Note that the maximum combined consumption for digital outputs 1, 2 &amp; 3 and C9 should not exceed 300mA.</p> <p>Some typical loads are given below:</p> <p>Microtach : 75mA Relays : 50mA each Fiber Optic ancillaries : 50mA each DeviceNetTechnology Box : 50mA</p>	N/A	C9

Terminal Information - Option Boards			
Terminal Description	Terminal Function	Signal Level	Terminal Number
<b>TERMINAL BLOCK G (SWITCHABLE TACHO CALIBRATION OPTION)</b>			
+ AC Tacho input	+AC		G1
- AC Tacho input	- AC		G2
+ DC Tacho input	+DC		G3
- DC Tacho input	- DC		G4
Tacho Out	Calibrated Tacho Output		P3
<b>(5701 MICROTACH RECEIVE OPTION - PLASTIC)</b>			
Signal Input	Microtach fibre optic input	There are no other connections to this option module. (The 5701 Microtach should be powered by an external 24V DC at 60mA, 1.4W.)	F1
<b>(5901 MICROTACH OPTION MODULE - GLASS)</b>			
Signal Input	Microtach fibre optic input	There are no other connections to this option module. (The 5901 Microtach should be powered by an external 24V DC at 125mA, 3W.)	F1
<b>TERMINAL BLOCK G (ENCODER OPTION)</b>			
Terminal Block G pinouts will change function depending upon which option board is fitted to the control board. The configuration supplied as standard is with the Switchable Tacho Calibration Option fitted. Further information on the other options may be obtained from the relevant Technical Manual.			
<b>TERMINAL BLOCK H (SERIAL COMMUNICATIONS)</b>			
<i>Note: Where more than 8 serial communications option boards are interconnected on one system, the line termination resistor fitted to the option board causes excessive loading on the system. The resistor should be removed on boards daisy chained in the serial wiring, not those at the beginning or end of the system. Refer to Parker SSD Drives if in doubt.</i>			
RS485			
XMT-	Serial Communications Port P1 Transmit Terminals		H1
XMT +	Balanced Line Driver outputs compatible with RS422 signal levels		H2
0V Isolated	Serial Communications Port		H3
0V Isolated	Signal ground with galvanic isolation from controller signal ground or power ground (note that the signal screen must also be grounded at the host)		H4



## E-22 Technical Specifications

Terminal Information - Option Boards			
Terminal Description	Terminal Function	Signal Level	Terminal Number
RCV- RCV+	Serial Communications Port P1 Receive Terminals Balance Line Receiver input compatible with RS422 signal levels		H5 H6
PROFIBUS			
0Vext +5VDCext B-B` A-A` RTS 0Vext	Signal reference for Profibus +5VDCext/50mA supply for Profibus Receive/Transmit-Data-P Receive/Transmit-Data-N For connecting repeater As pin 1		H1 H2 H3 H4 H5 H6

Wiring Requirements for EMC Compliance					
Where shielded/armoured cables are specified, use "SY" or "CY" type cables for better performance.					
	Model	Power Supply Cable	Motor Cable	External Filter to Converter Cable	Signal/Control Cable
Cable Type (for EMC Compliance)		Unscreened	Screened/ armoured	Replace flying leads with screened/armoured when >0.6m	Screened
Segregation		From all other wiring (clean)	From all other wiring (noisy)		From all other wiring (sensitive)
Length Limitations With External Filter		Unlimited	50 metres	As short as possible	25 metres
Screen to Ground Connection			Both ends	Both ends	Converter end only

## Wire Sizes and Termination Tightening Torques (Frames 1, 2, 3, 4 & 5)

- Control wiring must have a minimum cross-section area of 0.75mm<sup>2</sup> (18AWG)

Terminations	Maximum Tightening Torque	UL		EUROPE
		Recommended Wire Size	Maximum Terminal Aperture Size (AWG)	Maximum Terminal Aperture Size (mm <sup>2</sup> )
<b>All Units</b>				
A1 – A9, B1 – B9, C1 – C9	0.6-0.8Nm (5-7 lb-in.)	14 AWG	12	2.5
<b>Frame 1</b>				
<b>15A, 35A UNITS</b>				
A+, A-	1.8Nm (16 lb-in)	8-18 AWG	8	10
L1, L2, L3	1.8Nm (16 lb-in)	8-18 AWG	8	10
Grounding terminal	2.0Nm (17 lb-in.)	12 AWG	-	-
AUX. CONT. (TB4)	0.5Nm (5.0 lb-in)	12 AWG	12	2.5
F+, F-	0.8Nm (7.0 lb-in)	14 AWG	12	2.5
BL1, BL2, BL3	0.8Nm (7.0 lb-in)	12-22 AWG *	12	2.5
L, N, 3, 4, TH1, TH2	0.5Nm (5.0 lb-in)	12 AWG	12	2.5

## E-24 Technical Specifications

### Wire Sizes and Termination Tightening Torques (Frames 1, 2, 3, 4 & 5)

- Control wiring must have a minimum cross-section area of 0.75mm<sup>2</sup> (18AWG)

Terminations	Maximum Tightening Torque	UL		EUROPE
		Recommended Wire Size	Maximum Terminal Aperture Size (AWG)	Maximum Terminal Aperture Size (mm <sup>2</sup> )
<b>Frame 2 *</b>				
<b>40A UNITS</b>				
A+, A-	5.6Nm (50 lb-in)	8 AWG	2/0	70
L1, L2, L3	5.6Nm (50 lb-in)	8 AWG	2/0	70
Grounding terminal	5.6Nm (50 lb-in)	6 AWG	2/0	70
AUX. CONT. (TB4)	0.5Nm (5.0 lb-in)	12 AWG	12	2.5
FL1, FL2, F+, F-	0.8Nm (7.0 lb-in)	14 AWG	12	2.5
BL1, BL2, BL3	0.8Nm (7.0 lb-in)	6-18 AWG *	12	2.5
L, N, 3, 4, TH1, TH2	0.5Nm (5.0 lb-in)	12 AWG	12	2.5
<b>70A UNITS</b>				
A+, A-	5.6Nm (50 lb-in)	3 AWG	2/0	70
L1, L2, L3	5.6Nm (50 lb-in)	6 AWG	2/0	70
Grounding terminal	5.6Nm (50 lb-in)	6 AWG	2/0	70
AUX. CONT. (TB4)	0.5Nm (5.0 lb-in)	12 AWG	12	2.5
FL1, FL2, F+, F-	0.8Nm (7.0 lb-in)	14 AWG	12	2.5
BL1, BL2, BL3	0.8Nm (7.0 lb-in)	6-18 AWG *	12	2.5
L, N, 3, 4, TH1, TH2	0.5Nm (5.0 lb-in)	12 AWG	12	2.5
<b>110A UNITS</b>				
A+, A-	5.6Nm (50 lb-in)	1/0 AWG	2/0	70
L1, L2, L3	5.6Nm (50 lb-in)	3 AWG	2/0	70
Grounding terminal	5.6Nm (50 lb-in)	6 AWG	2/0	70
AUX. CONT. (TB4)	0.5Nm (5.0 lb-in)	12 AWG	12	2.5
FL1, FL2, F+, F-	0.8Nm (7.0 lb-in)	14 AWG	12	2.5
BL1, BL2, BL3	0.8Nm (7.0 lb-in)	6-18 AWG *	12	2.5
L, N, 3, 4, TH1, TH2	0.5Nm (5.0 lb-in)	12 AWG	12	2.5
<b>165A UNITS</b>				
A+, A-	42.4Nm (375 lb-in)	4/0 AWG	250 cmil	120

\* Power cables must have a minimum rating of 1.1 x full load current - EUROPE

## Wire Sizes and Termination Tightening Torques (Frames 1, 2, 3, 4 & 5)

- Control wiring must have a minimum cross-section area of 0.75mm<sup>2</sup> (18AWG)

Terminations	Maximum Tightening Torque	UL		EUROPE
		Recommended Wire Size	Maximum Terminal Aperture Size (AWG)	Maximum Terminal Aperture Size (mm <sup>2</sup> )
L1, L2, L3	5.6Nm (50 lb-in)	1/0 AWG	2/0	70
Grounding terminal	5.6Nm (50 lb-in)	3 AWG	2/0	70
AUX. CONT. (TB4)	0.5Nm (5.0 lb-in)	12 AWG	12	2.5
FL1, FL2, F+, F-	0.8Nm (7.0 lb-in)	14 AWG	12	2.5
BL1, BL2, BL3	0.8Nm (7.0 lb-in)	6-18 AWG *	12	2.5
L, N, 3, 4, TH1, TH2	0.5Nm (5.0 lb-in)	12 AWG	12	2.5
<b>Frame 3</b>				
<b>180A, 270A UNITS</b>				
A+, A-	11Nm (97 lb-in)	2/0 AWG	-	-
L1, L2, L3	11Nm (97 lb-in)	2/0 AWG	-	-
Grounding terminal	6.8Nm (60 lb-in)	2/0 AWG	-	-
D1- D8	0.45Nm (4.0 lb-in)	14 AWG	-	-
THERM+, THERM-	0.45Nm (4.0 lb-in)	14 AWG	-	-
<b>Frame 4 &amp; 5</b>				
<b>380A, 500A, 725A, 830A, 1580A UNITS</b>				
A+, A-	23Nm (204 lb-in)		-	-
L1, L2, L3	23Nm (204 lb-in)		-	-
Grounding terminal	6.8Nm (60 lb-in)		-	-
FL1, FL2	0.8Nm (7 lb-in)		-	-
F+, F-	0.8Nm (7 lb-in)*		-	-
Auxiliary supply, contactor and motor thermistor	0.6Nm (5 lb-in)		-	-

---

\* Power cables must have a minimum rating of 1.1 x full load current - EUROPE

## E-26 Technical Specifications

Termination Tightening Torque (Frame 6)				
Description	Fixings	Spanner Size	Format	Torque Nm
ACCT central bolt	M12	19mm	Bolts	45Nm (33 ft/lbf)
Fishplate fixings for A+, A-, L1, L2, L3	M10	17mm	Nut insert	55Nm (40.6 ft/lbf)
Phase Assembly Mountings	M10	17mm	Bolt	32Nm (23.6 ft/lbf)
Control Panel Assembly (support screws)	M6	10mm	Screw	4.5Nm (3.3 ft/lbf)
Fuse Assembly to Mounting Plate	M12	19mm	Bolt	45Nm (33 ft/lbf)
Fuse Assembly/Mounting Plate to Phase Assembly	M10	17mm	Bolt	32Nm (23.6 ft/lbf)

Termination Tightening Torque (Frame 7)				
Description	Fixings	Spanner Size	Format	Torque Nm
Drive Mounting Fixings	M12	19mm	Bolt	57.2
Ground studs on back panel	M10	17mm	Nut	32.8
Fuse assy to Phase assy	M10	17mm	Bolt	24
AC Input & DC Output Bus bars	M12	19mm	Nut & Bolt	57.2
Fuse assembly	M12	19mm	Bolt	42
Fuse assembly to CT	M12	19mm	Bolt	42
DC Output terminal panel to side panel	M6	10mm	Bolt	6.8
DC Bus bars	M6	10mm	Nut	6.8
I/P terminal assy	M6	10mm	Nut	4
Lifting Bracket Fixings	M10	17mm	Bolt	24

Dynamic Braking	
External Braking unit with contactor available on Frame 1 and Frame 2 units.	
Current Rating of Contactor Switch	150% of armature current for 30 seconds
Rating	Resistor to meet NEMA ICS 3-302.62 (to stop a load from base speed with 2 x motor inertia three times in rapid succession).

Cooling Fans						
Drive Rating (Hp @ 240/500V)	Output Current (armature) (A)	Maximum Rating Ambient <sup>1</sup> (°C)	Cooling Method	Number of Fans	Fan Current Rating 110/120V ac	Fan Current Rating 220/240V ac
<b>Frame 1</b>						
3/7.5	15	45	no fan	0	N/A	N/A
10/20	35	45	Integral Fan	1	N/A	N/A
<b>Frame 2</b>						
10/20	40	45	Integral Fan	1	N/A	N/A
15/30	55	45	Integral Fan	1	N/A	N/A
20/40	70	45	Integral Fan	1	N/A	N/A
25/50	90	45	Integral Fan	1	N/A	N/A
30/60	110	45	Integral Fan	1	N/A	N/A
40/75	125	45	Integral Fan	1	N/A	N/A
50/100	165	45	Integral Fan	1	N/A	N/A
<b>Frame 3</b>						
60/125	206	45	Integral Fan	1	N/A	N/A
75/150	243	45	Integral Fan	1	N/A	N/A
<b>Frame 4</b>						
200	360	40	Forced Vent 240cfm (410m <sup>3</sup> /hr) @ 200Pa	1	130W, 10μF	140W, 2.5μF
250	425	40	Forced Vent 240cfm (410m <sup>3</sup> /hr) @ 200Pa	1	130W, 10μF	140W, 2.5μF
300	490	40	Forced Vent 240cfm (410m <sup>3</sup> /hr) @ 200Pa	1	130W, 10μF	140W, 2.5μF
400	700	40	Forced Vent 240cfm (410m <sup>3</sup> /hr) @ 200Pa	1	130W, 10μF	140W, 2.5μF
500	815	40	Forced Vent 240cfm (410m <sup>3</sup> /hr) @ 200Pa	1	130W, 10μF	140W, 2.5μF
<b>Frame 5</b>						
900	1580	40	Forced Vent 240cfm (410m <sup>3</sup> /hr) @ 200Pa	2	130W, 10μF	140W, 2.5μF
<b>Frame 6</b>						
All ratings	All ratings	40	Integral Fan (6 x 24V dc)	6 (internal)	48W See note below	48W See note below
<b>Frame 7</b>						
900	1200	40	Separate Fan	2	See note below	See note below
1000	1700	40	Separate Fan	2	See note below	See note below
1250	2200	40	Separate Fan	2	See note below	See note below
1500	2700	40	Separate Fan	2	See note below	See note below
Fans supplied with Frame 6 units have an air flow rate of 215cfm per fan (2 per phase assembly, 6 in total) Fan SMPS: 115V ±10%, 3A, 300W or 230V ±10%, 1.5A, 300W Assembly Part Number LA466819			Fans supplied with Frame 7 units have an air flow rate per fan of 850m <sup>3</sup> /hr at 250 Pascal Fan Ratings: 115V ac 50Hz, 1.67A, 177W, 2750 rpm, motor run capacitor 18μF 115V ac 60Hz, 2.21A, 240W, 2660 rpm, motor run capacitor 18μF			

## E-28 Technical Specifications

Spares List (Frames 1-5 & 7)						
Common Spares						
Control Board Cradle / Control Door			LED Board	Ribbon Cable		
Frame	Part Number					
1 & 2	LA460617U004 (Cradle)	AH465315U001				CM467762U002
3 & 7	590PXD/0011/UK//00	-				-
4 & 5	590PD/0011/UK//00	-				-
Frame 1						
Product	Power Board	Terminal Board	<i>Armature Thyristor</i>	Field Bridge	Fan	Fan Assy
955+8N0007	AH470280U007	AH466407U001	-	-	-	-
955+8R0007	AH470280U008	AH466407U001	-	-	-	-
955+8N0020	AH470280U007	AH466407U001	-	-	-	-
955+8R0020	AH470280U008	AH466407U001	-	-	-	-

Spares List (Frames 1-5 & 7)						
<b>Frame 2</b>						
Product	Power Board	Terminal Board	<i>Armature Thyristor</i>	Field Bridge	Fan	Fan Assy
955+8N0030 / 955+8N0040	AH470330U007*	-	CF385524U016		DL465313	No Sub Assembly
955+8R0030 / 955+8R0040	AH470330U008*	-	CF385524U016		DL465313	No Sub Assembly
955+8N0050 / 955+8N0060	AH470330U007*	-	CF470523U095		DL465313	No Sub Assembly
955+8R0050 / 955+8R0060	AH470330U008*	-	CF470523U095		DL465313	No Sub Assembly
955+8N0075 / 955+8N0100	AH470330U007*	-	CF470523U095		DL465313	No Sub Assembly
955+8R0075 / 955+8R0100	AH470330U008*	-	CF470523U095		DL465313	No Sub Assembly
<b>Frame 3</b> Fitted with the 590PXD Door Assembly LA466454U001 containing the Control Board and Adaptor Board AH466405U001						
Product	Power Board	<i>Armature Thyristor</i>	Field Bridge	Fan 115V	Fan 230V	
955+8N0125	AH385851U003	CF057366U016	CF057273U016	DL043707		
955+8R0125	AH385851U002	CF057366U016	CF057273U016	DL043707		
955+8N0150	AH385851U003	CF057366U016	CF057273U016	DL043707		
955+8R0150	AH385851U002	CF057366U016	CF057273U016	DL043707		

**NOTE** \* This PCB is a composite assembly and contains a Power Board, a Terminal Board and a CT Board



## E-30 Technical Specifications

<b>Spares List (Frames 1-5 &amp; 7)</b>				
<b>Frame 4</b> Fitted with the 590PD Door Assembly LA466454U002 containing the Control Board				
<b>Product</b>	<b>Power Board</b>	<b>Suppression Board</b>	<b>Trigger Board</b>	<b>Thyristor</b>
955+8N0200-D4	AH466701U002	AH466704U001	AH466703U002	CF466796U016
955+8R0200-D4	AH466701U002	AH466704U001	AH466703U002	CF466796U016
955+8N0250-D4 / 955+8N0250-D4	AH466701U002	AH466704U001	AH466703U002	CF466768U016
955+8R0300-D4 / 955+8R0300-D4	AH466701U002	AH466704U001	AH466703U002	CF466768U016
955+8N0400-D4	AH466701U002	AH466704U001	AH466703U002	CF466697U016
955+8R0400-D4	AH466701U002	AH466704U001	AH466703U002	CF466697U016
955+8N0500-D4	AH466701U002	AH466704U001	AH466703U002	CF466767U016
955+8R0500-D4	AH466701U002	AH466704U001	AH466703U002	CF466767U016
955+8CN0200-D4	AH466701U003	AH466704U002	AH466703U002	CF466796U018
955+8CR0200-D4	AH466701U003	AH466704U002	AH466703U002	CF466796U018
955+8CN0250-D4 / 955+8N0250-D4	AH466701U003	AH466704U002	AH466703U002	CF466768U018
955+8RN0300-D4 / 955+8R0300-D4	AH466701U003	AH466704U002	AH466703U002	CF466768U018
955+8CN0400-D4	AH466701U003	AH466704U002	AH466703U002	CF466697U018
955+8CR0400-D4	AH466701U003	AH466704U002	AH466703U002	CF466697U018
955+8CN0500-D4	AH466701U003	AH466704U002	AH466703U002	CF466767U018
955+8CR0500-D4	AH466701U003	AH466704U002	AH466703U002	CF466767U018

<b>Spares List (Frames 1-5 &amp; 7)</b>				
<b>Frame 4</b> Fitted with the 590PD Door Assembly LA466454U002 containing the Control Board				
<b>Product</b>	<b>Field Thyristor</b>	<b>Field Diode</b>	<b>Fan + Capacitor Assembly 115V</b>	<b>Fan + Capacitor Assembly 230V</b>
955+8N0200-D4	CF385522U016	CW464320U016	LA466711U001	
955+8R0200-D4	CF385522U016	CW464320U016	LA466711U001	
955+8N0250-D4/ 955+8N0250 D4	CF385522U016	CW464320U016	LA466711U001	
955+8R0300-D4 /955+8R0300-D4	CF385522U016	CW464320U016	LA466711U001	
955+8N0400-D4	CF385522U016	CW464320U016	LA466711U001	
955+8R0400-D4	CF385522U016	CW464320U016	LA466711U001	
955+8N0500-D4	CF385522U016	CW464320U016	LA466711U001	
955+8R0500-D4	CF385522U016	CW464320U016	LA466711U001	
955+CN0250-D4	CF385523U018	CW464320U018	LA466711U001	
955+CR0250-D4	CF385523U018	CW464320U018	LA466711U001	
955+CN0300-D4	CF385523U018	CW464320U018	LA466711U001	
955+CR0300-D4	CF385523U018	CW464320U018	LA466711U001	
955+CN0500-D4	CF385523U018	CW464320U018	LA466711U001	
955+CR0500-D4	CF385523U018	CW464320U018	LA466711U001	
955+CN0600-D4	CF385523U018	CW464320U018	LA466711U001	
955+CR0600-D4	CF385523U018	CW464320U018	LA466711U001	

## E-32 Technical Specifications

<b>Spares List (Frames 1-5 &amp; 7)</b>				
<b>Frame 5</b> Fitted with the 590PD Door Assembly LA466454U002 containing the Control Board				
<b>Product</b>	<b>Power Board</b>	<b>Suppression Board</b>	<b>Trigger Board</b>	<b>Slave Power</b>
955+8N0600-D5 955+8N0700-D5 955+8N0800-D5 955+8N0900-D5	AH466701U002	AH466704U001	AH466703U002	* AH466706U002
955+8R0600-D5 955+8R0700-D5 955+8R0800-D5 955+CN0700-D5 955+CN0800-D5 955+CN0900-D5 955+CN1000-D5 955+CR0700-D5 955+CR0800-D5 955+CR0900-D5 955+CR1000-D5	AH466701U002   AH466701U003   AH466701U003	AH466704U001   AH466704U002   AH466704U002	AH466703U002   AH466703U002   AH466703U002	* AH466706U002   * AH466706U003   * AH466706U003

**Note:** \* This PCB is a composite assembly and contains a Power Board and a Parallel Expansion Board

\* CR / CN = 575 VAC Build

<b>Spares List (Frames 1-5 &amp; 7)</b>					
<b>Product</b>	<b>Thyristor</b>	<b>Field Thyristor</b>	<b>Field Diode</b>	<b>Fan + Capacitor Assembly 115V</b>	<b>Fan + Capacitor Assembly 230V</b>
955+8N0600-D5 955+8N0700-D5 955+8N0800-D5 955+8N0900-D5 955+8R0600-D5 955+8R0700-D5 955+8R0800-D5 955+8R0900-D5	CF466767U016	CF385522U016	CW464320U016	LA466711U001	
955+CN0700-D5 955+CN0800-D5 955+CN0900-D5 955+CN1000-D5 955+CR0700-D5 955+CR0800-D5 955+CR0900-D5 955+CR1000-D5	CF466767U018	CF385523U018	CW464320U018	LA466711U001	
	CF466767U018	CF385523U018	CW464320U018	LA466711U001	

## E-34 Technical Specifications

Frame 7 Fitted with the 590PXD Door Assembly LA466454U001 containing the Control Board and Adaptor Board AH466405U001				
Product	Power Board	Trigger Board	Suppression Board	Snubber Board
955+8N0600	AH466001U101	AH466003U001	AH466003U003	AH466004U001
955+8R0600	AH466001U101	AH466003U001		AH466004U001
955+8N0900	AH466001U101	AH466003U001	AH466003U003	AH466004U001
955+8R0900	AH466001U101	AH466003U001		AH466004U001
955+8N1250	AH466001U101	AH466003U101	AH466003U103	AH466004U101
955+8R1250	AH466001U101	AH466003U101		AH466004U101
955+8N1500	AH466001U101	AH466003U101	AH466003U103	AH466004U101
955+8R1500	AH466001U101	AH466003U101		AH466004U101
955+CN0700	AH466001U001	AH466003U002	AH466003U004	AH466004U002
955+CR0700	AH466001U001	AH466003U002		AH466004U002
955+CN1000	AH466001U001	AH466003U002	AH466003U004	AH466004U002
955+DR1000	AH466001U001	AH466003U002		AH466004U002
955+CN1500	AH466001U001	AH466003U102	AH466003U104	AH466004U102
955+CR1500	AH466001U001	AH466003U102		AH466004U102
955+CN1750	AH466001U001	AH466003U102	AH466003U104	AH466004U102
955+CR1750	AH466001U001	AH466003U102		AH466004U102
Frame 7 Fitted with the 590PXD Door Assembly LA466454U001 containing the Control Board and Adaptor Board AH466405U001				
Product	Field Assembly	Phase Assembly	Fuses	Fan 110V
955+8N0600	LA466030U001	LA466059U012	CS466260U050	DL466242
955+8R0600	LA466030U001	LA466059U012	CS466261U035	DL466242
955+8N0900	LA466030U001	LA466059U017	CS466260U080	DL466242
955+8R0900	LA466030U001	LA466059U017	CS466261U055	DL466242
955+8N1250	LA466030U001	LA466059U022	CS466260U100	DL466242
955+8R1250	LA466030U001	LA466059U022	CS466261U070	DL466242
955+8N1500	LA466030U001	LA466059U027	CS466260U125	DL466242
955+8R1500	LA466030U001	LA466059U027	CS466261U090	DL466242
955+CN0700	LA466030U002	LA466059U112	CS466260U050	DL466242
955+CR0700	LA466030U002	LA466059U112	CS466261U035	DL466242
955+CN01000	LA466030U002	LA466059U117	CS466260U080	DL466242
955+CR01000	LA466030U002	LA466059U117	CS466261U055	DL466242
955+CN1500	LA466030U002	LA466059U122	CS466260U100	DL466242
955+CR1500	LA466030U002	LA466059U122	CS466261U070	DL466242
955+CN1750	LA466030U002	LA466059U127	CS466260U125	DL466242
955+CR1750	LA466030U002	LA466059U127	CS466261U090	DL466242

<b>Spares List (Frame 6)</b>				
<b>590P - Regenerative (4Q)</b>				
<b>Drive Model Number</b>		<b>955+8R0700-D6</b>	<b>955+8R1000-D6</b>	<b>955+8R1200-D6</b>
<b>Gantry</b>		590PG/500/0011/UK/000	590PG/500/0011/UK/000	590PG/500/0011/UK/000
<b>Gantry Parts</b>	<b>Door</b>	590PXD	590PXD	590PXD
	<b>Power Board</b>	AH469419U012	AH469419U012	AH469419U012
	<b>Field Assembly</b>	LA466030U001	LA466030U001	LA466030U001
	<b>Fan SMPS</b>	LA466819	LA466819	LA466819
<b>Phase Assembly</b>	<b>Recommended Spare</b>	590PL/1250/500	590PL/1600/500	590PL/1950/500
<b>Phase Assembly Parts</b>	<b>Fuse</b>	CS466261U070	CS466261U100	CS466261U125
	<i>Thyristor</i>	<i>CF469820U016</i>	<i>CF469821U016</i>	<i>CF469822U016</i>
	<i>Clamp</i>	<i>LA469670U002</i>	<i>LA469670U002</i>	<i>LA469670U003</i>
<b>Possible Spare Parts</b>	<i>Thermostat</i>	<i>CM469898U002</i>	<i>CM469898U003</i>	<i>CM469898U004</i>
<b>Drive Model Number</b>		<b>955+CR0900-D6</b>	<b>955+CR1200-D6</b>	<b>55+CR1300-D6</b>
<b>Gantry</b>		590PG/690/0011/UK/000	590PG/690/0011/UK/000	590PG/690/0011/UK/000
<b>Gantry Parts</b>	<b>Door</b>	590PXD	590PXD	590PXD
	<b>Power Board</b>	AH469419U011	AH469419U011	AH469419U011
	<b>Field Assembly</b>	LA466030U002	LA466030U002	LA466030U002
	<b>Fan SMPS</b>	LA466819	LA466819	LA466819
<b>Phase Assembly</b>	<b>Recommended Spare</b>	590PL/1250/690	590PL/1600/690	590PL/1950/690
<b>Phase Assembly Parts</b>	<b>Fuse</b>	CS466261U070	CS466261U100	CS466261U125

## E-36 Technical Specifications

<b>Spares List (Frame 6)</b>				
<b>591P - Non-Regenerative (2Q)</b>				
<b>Drive Model Number</b>		<b>591P/1250/500</b>	<b>591P/1600/500</b>	<b>591P/1950/500</b>
<b>Gantry</b>		590PG/500/0011/UK/000	590PG/500/0011/UK/000	590PG/500/0011/UK/000
<b>Gantry Parts</b>	<b>Door</b>	590PXD	590PXD	590PXD
	<b>Power Board</b>	AH469419U012	AH469419U012	AH469419U012
	<b>Field Assembly</b>	LA466030U001	LA466030U001	LA466030U001
	<b>Fan SMPS</b>	LA466819	LA466819	LA466819
<b>Phase Assembly</b>	<b>Recommended Spare</b>	591PL/1250/500	591PL/1600/500	591PL/1950/500
<b>Phase Assembly Parts</b>	<b>Fuse</b>	CS466260U100	CS466260U140	CS466260U180
<b>Drive Model Number</b>		<b>955+CN0900-D6</b>	<b>955+CN1200-D6</b>	<b>55+CN1300-D6</b>
<b>Gantry</b>		590PG/690/0011/UK/000	590PG/690/0011/UK/000	590PG/690/0011/UK/000
<b>Gantry Parts</b>	<b>Door</b>	590PXD	590PXD	590PXD
	<b>Power Board</b>	AH469419U011	AH469419U011	AH469419U011
	<b>Field Assembly</b>	LA466030U002	LA466030U002	LA466030U002
	<b>Fan SMPS</b>	LA466819	LA466819	LA466819
<b>Phase Assembly</b>	<b>Recommended Spare</b>	591PL/1250/690	591PL/1600/690	591PL/1950/690
<b>Phase Assembly Parts</b>	<b>Fuse</b>	CS466260U100	CS466260U140	CS466260U180

*Do not attempt to upgrade by fitting a later software version Control Board. You may experience hardware compatibility problems. If in doubt, contact Parker SSD Drives.*

# Parker Worldwide

**AE – UAE, Dubai**

Tel: +971 4 8127100

parker.me@parker.com

**AR – Argentina, Buenos Aires**

Tel: +54 3327 44 4129

**AT – Austria, Wiener Neustadt**

Tel: +43 (0)2622 23501-0

parker.austria@parker.com

**AT – Eastern Europe, Wiener Neustadt**

Tel: +43 (0)2622 23501 900

parker.easteurope@parker.com

**AU – Australia, Castle Hill**

Tel: +61 (0)2-9634 7777

**AZ – Azerbaijan, Baku**

Tel: +994 50 2233 458

parker.azerbaijan@parker.com

**BE/LU – Belgium, Nivelles**

Tel: +32 (0)67 280 900

parker.belgium@parker.com

**BR – Brazil, Cachoeirinha RS**

Tel: +55 51 3470 9144

**BY – Belarus, Minsk**

Tel: +375 17 209 9399

parker.belarus@parker.com

**CA – Canada, Milton, Ontario**

Tel: +1 905 693 3000

**CH – Switzerland, Etoy**

Tel: +41 (0)21 821 87 00

parker.switzerland@parker.com

**CL – Chile, Santiago**

Tel: +56 2 623 1216

**CN – China, Shanghai**

Tel: +86 21 2899 5000

**CZ – Czech Republic, Klecany**

Tel: +420 284 083 111

parker.czechrepublic@parker.com

**DE – Germany, Kaarst**

Tel: +49 (0)2131 4016 0

parker.germany@parker.com

**DK – Denmark, Ballerup**

Tel: +45 43 56 04 00

parker.denmark@parker.com

**ES – Spain, Madrid**

Tel: +34 902 330 001

parker.spain@parker.com

**FI – Finland, Vantaa**

Tel: +358 (0)20 753 2500

parker.finland@parker.com

**FR – France, Contamine s/Arve**

Tel: +33 (0)4 50 25 80 25

parker.france@parker.com

**GR – Greece, Athens**

Tel: +30 210 933 6450

parker.greece@parker.com

**HK – Hong Kong**

Tel: +852 2428 8008

**HU – Hungary, Budapest**

Tel: +36 1 220 4155

parker.hungary@parker.com

**IE – Ireland, Dublin**

Tel: +353 (0)1 466 6370

parker.ireland@parker.com

**IN – India, Mumbai**

Tel: +91 22 6513 7081-85

**IT – Italy, Corsico (MI)**

Tel: +39 02 45 19 21

parker.italy@parker.com

**JP – Japan, Tokyo**

Tel: +81 (0)3 6408 3901

**KR – South Korea, Seoul**

Tel: +82 2 559 0400

**KZ – Kazakhstan, Almaty**

Tel: +7 7272 505 800

parker.easteurope@parker.com

**MX – Mexico, Apodaca**

Tel: +52 81 8156 6000

**MY – Malaysia, Shah Alam**

Tel: +60 3 7849 0800

**NL – The Netherlands, Oldenzaal**

Tel: +31 (0)541 585 000

parker.nl@parker.com

**NO – Norway, Asker**

Tel: +47 66 75 34 00

parker.norway@parker.com

**NZ – New Zealand, Mt Wellington**

Tel: +64 9 574 1744

**PL – Poland, Warsaw**

Tel: +48 (0)22 573 24 00

parker.poland@parker.com

**PT – Portugal, Leca da Palmeira**

Tel: +351 22 999 7360

parker.portugal@parker.com

**RO – Romania, Bucharest**

Tel: +40 21 252 1382

parker.romania@parker.com

**RU – Russia, Moscow**

Tel: +7 495 645-2156

parker.russia@parker.com

**SE – Sweden, Spånga**

Tel: +46 (0)8 59 79 50 00

parker.sweden@parker.com

**SG – Singapore**

Tel: +65 6887 6300

**SK – Slovakia, Banská Bystrica**

Tel: +421 484 162 252

parker.slovakia@parker.com

**SL – Slovenia, Novo Mesto**

Tel: +386 7 337 6650

parker.slovenia@parker.com

**TH – Thailand, Bangkok**

Tel: +662 717 8140

**TR – Turkey, Istanbul**

Tel: +90 216 4997081

parker.turkey@parker.com

**TW – Taiwan, Taipei**

Tel: +886 2 2298 8987

**UA – Ukraine, Kiev**

Tel: +380 44 494 2731

parker.ukraine@parker.com

**UK – United Kingdom, Warwick**

Tel: +44 (0)1926 317 878

parker.uk@parker.com

**US – USA, Cleveland**

Tel: +1 216 896 3000

**VE – Venezuela, Caracas**

Tel: +58 212 238 5422

**ZA – South Africa, Kempton Park**

Tel: +27 (0)11 961 0700

parker.southafrica@parker.com

© XXXX to YYYY Parker Hannifin Corporation. All rights reserved.

**Parker Hannifin Manufacturing Limited**

Automation Group, SSD Drives Europe,

New Courtwick Lane,

Littlehampton, West Sussex BN17 7RZ

United Kingdom

Tel: +44 (0)1903 737000

Fax: +44 (0)1903 737100

www.parker.com/ssd

**European Product Information Centre**

Free phone: 00 800 27 27 5374

(from AT, BE, CH, CZ, DE, EE, ES, FI, FR, IE, IL, IS, IT, LU, MT, NL, NO, PT, SE, SK, UK)



\* H A 4 7 0 3 8 8 U 0 0 3 - 0 4 \*