

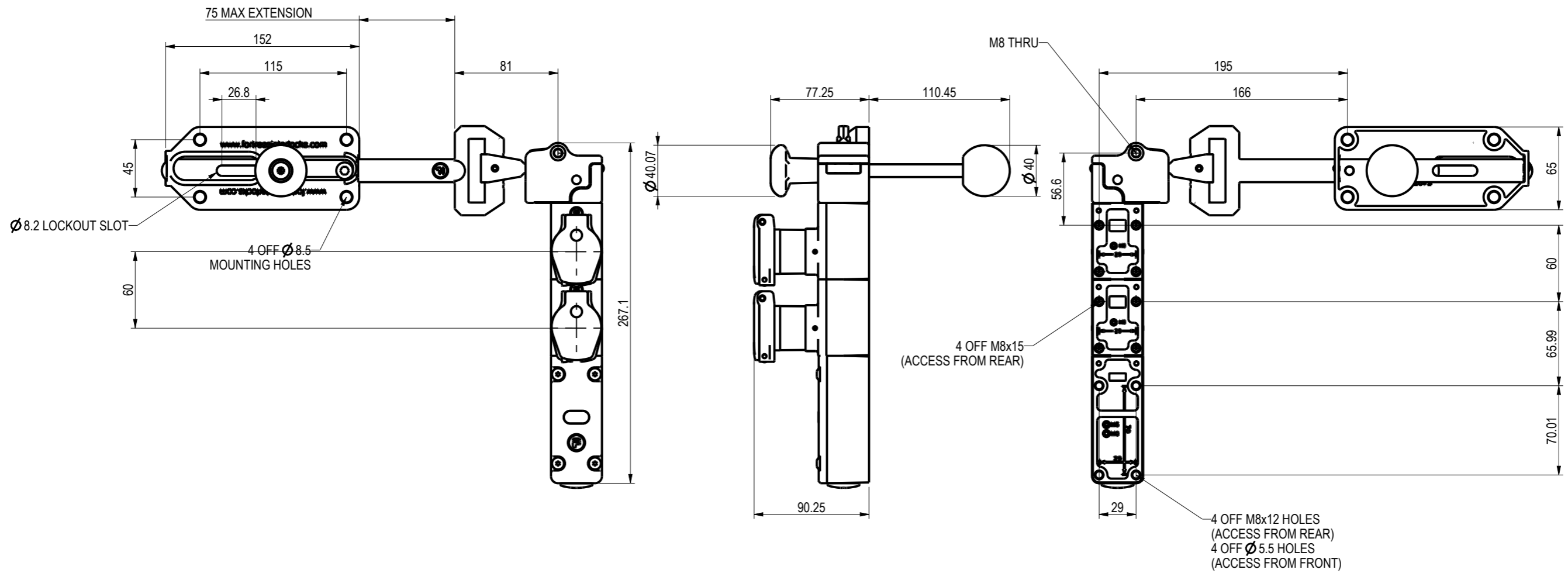

A B C D E F G H I J K L

1
2
3
4
5
6
7
8
9

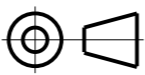

NOTE:
ALL FIXING POINTS ARE TO ACCUMULATE
AN INCREMENT TOLERANCE OF ±0.2mm

THE COPYRIGHT OF THIS DRAWING BELONGS TO FORTRESS INTERLOCKS Ltd. THE CONTENT OF THIS DRAWING IS CONFIDENTIAL AND MUST NOT BE DISCLOSED TO ANY 3rd PARTY WITHOUT OUR SPECIFIC, WRITTEN APPROVAL.		TITLE:		ISSUE: 0	
		T12-T6-SKL71-AKL71-ST401		RELEASE LEVEL: Design In Progress	
 www.fortressinterlocks.com		DO NOT SCALE. IF IN DOUBT ASK! ALL DIMENSIONS ARE IN mm (UOS)	DWG NO:ITM-00277785A222149	PART NO:ITM-00277785A222149	DATE: 27-08-18
		REMOVE ALL SHARP EDGES, BURRS AND FLASH	SHEET 1 OF 1	SCALE: 0.29	DRAWN BY: AUTO
 ORIGINAL SIZE A3		MATERIAL:NOT APPLICABLE	FINISH:SELF	GENERAL TOLERANCE: ±0.1 / ±0.5°	CHECKED BY: N/A
				VOLUME: MM^3	