SYSTEM 3000 / 4000

FLAME SCANNER
2.0 GT

TECHNICAL DESCRIPTION

Flame Scanner 2.0 GT

- Selective Monitoring of Gas- and Oil Flame
- TÜV and DIN-DVGW approved
- Fail-Safe, Self-Monitoring Complete Electronic Construction
- Spectral Procedure
- Type of Protection IP 65

Application

In connection with a flame detector of the **3000** or **4000** line, the flame scanner **2.0 GT** forms a complete flame monitoring system and meets the safety requirements for steam generators. The flame monitoring system **3000/4000** is tested and approved in accordance to EN298:2012.

Function

The flame scanner system **2.0 GT** is based on the UV-VIS spectral procedure and on the IR flame radiation analysis. Both spectral ranges are detected separately by a binary detector and evaluated selectively by means of an automatic pre-amplifier circuit and integrated frequency control.

This achieves an optimum spectral utilization of the high-frequency flame modulation of the primary combustion zone, thus avoiding suppression of the UV-VIS flicker frequencies, since the high energy IR radiation is processed separately. The generally undesired diffused light of the flame serves for the fuel specific control of the flame scanner.

The binary detector consists of a lead sulphide carrier with a vapour deposited silicon photo element. The Si element serves as an UV filter for the PbS photo element arranged behind it on the same optical axis, and blanks out the detrimental short waves which otherwise would cause problems with the PbS detectors. Due to a compensation controlled by the ambient tem-

perature, the working point of the scanner is stabilized and the spectral linearity is maintained. In a mixed stage the signals of both photo elements result in a bus signal of a very large spectral bandwidth. The spectral shift of the flame provides information about oxidation of the fuel thus offering information about the flame quality.

The signals of the UV-VIS and IR radiation intensity can be adjusted separately to achieve full evaluation of the flame. The on-load connected bandpass has the effect that the typical modulation of flame radiation of the primary combustion zone is utilized for the output signal only.

The further functional groups achieve the conversion into digital information acc. to standard with highest fail-safe features.

By means of the BFI special cable KW5 it is possible to realize a length of up to 500m without having to use a further driver unit between flame scanner and amplifier.

Dimensions

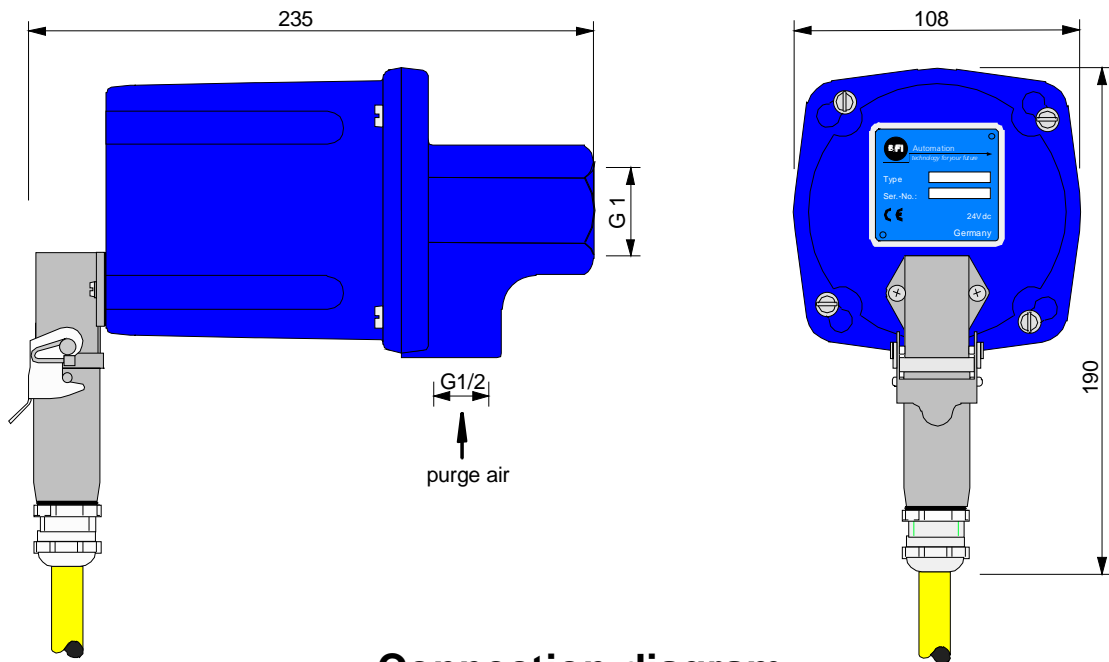

Connection diagram

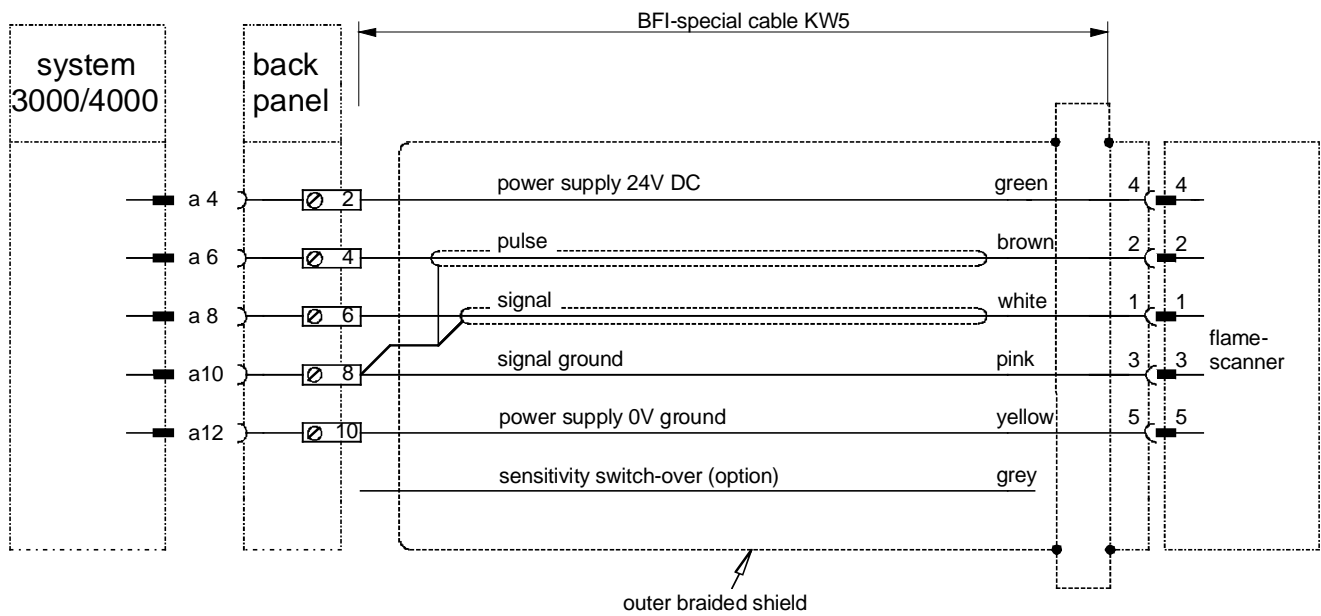

Technical Data

Self monitoring fail-safe function control accordance to EN298:2012. Approved accordance to DIN-DVGW.
Two spectral ranges for separate adjustment

Spectral sensitivity	300 to 2700 nm
Viewing angle	1°, 2° or 2,7°
Self-monitoring	fully electronic, 1* per second
Operating voltage	24 V DC, inner electrical isolation
Current consumption	max. 100 mA
Ambient temperature	-20 to +70 degrees
Electric connection	plug connector
Protection	IP 65
Length of cable	max. 500 m (KW 5)
Sight tube connection	1" internal thread. ISO 228
Purging air connection	1/2" internal thread ISO 228
Purging air quantity	10 m³/h at standard conditions
or	
Purging air pressure	0.02 bar over combustion chamber internal pressure
Weight	approximate 1.5 kg
Part no.	S 507H
Approvals	
CE	CE0085BS0478
DVGW	NG2530AS0248
CSA	1150499

This flame scanner is also available in an Ex-casing or in LWL – technique.